



## M-4209-G430M Ring and Pinion Set INSTALLATION INSTRUCTIONS

NO PART OF THIS DOCUMENT MAY BE REPRODUCED WITHOUT PRIOR AGREEMENT AND WRITTEN PERMISSION OF FORD RACING PERFORMANCE PARTS.

Please visit [www.fordracingparts.com](http://www.fordracingparts.com) for the most current instruction information

**!!! PLEASE READ ALL OF THE FOLLOWING INSTRUCTIONS CAREFULLY PRIOR TO INSTALLATION. AT ANY TIME YOU DO NOT UNDERSTAND THE INSTRUCTIONS, PLEASE CALL THE FORD RACING TECHLINE AT 1-800-367-3788 !!!**

### **INSTALLATION INSTRUCTIONS:**

- STEP 1:** Remove the old gear set and thoroughly clean both the ring gear carrier and rear end housing with solvent. After cleaning, air-dry all parts
- STEP 2:** Always verify you have the correct gear ratio that you have purchased. This can be checked by dividing the ring gear tooth count by the pinion tooth count (e.g., Ring gear tooth count – 35T, pinion gear tooth count – 10T. 35/10 or 3.50:1 ratio).
- STEP 3:** Many differential cases have many thousands of miles of service. Check all threads in the case for wear. It may be necessary to run an engineering tap to chase the threads to clean and align threads.
- STEP 4:** Check side bearing adjusters as they are often warped and out of shape making ring and pinion settings difficult. Replace as necessary.
- STEP 5:** Check ring gear back face for flatness. Generally after heat-treating there may be a degree of taper. This may be rectified by lapping gear on sand paper on a glass flat plate. This will give you a more even and uniform pattern when setting up your new gear set.
- STEP 6:** Careful attention should be given to blueprinting your rear end. Accurate clearance will lead to a longer life for your unit.
- STEP 7:** All new parts should be thoroughly cleaned and checked for damage before assembly.
- STEP 8:** Examine the ring gear mounting surface for nicks or burrs which might prevent a flush mounting of the newly installed ring gear. Ring/pinion tooth depth variations can result from a ring gear that is “cocked” on its mounting surface. If a ring gear spacer is to be used, also check it for surface imperfections. Nicks or burrs can be removed by using block-backed grit paper or a small file. Following material removal, rewash in solvent and air dry. Mount ring gear. Loctite ring gear bolts and torque to factory specifications.
- STEP 9:** All Ford Racing ring gear and pinions have been “Lapped” in sets and should never be mixed with another ring gear or pinion. Check to see serial numbers are the same on the ring gear and pinion.

Factory Ford shop manuals are available from Helm Publications, 1-800-782-4356

## M-4209-G430M Ring and Pinion Set INSTALLATION INSTRUCTIONS

NO PART OF THIS DOCUMENT MAY BE REPRODUCED WITHOUT PRIOR AGREEMENT AND WRITTEN PERMISSION OF FORD RACING PERFORMANCE PARTS.

- STEP 10:** Each Ford Racing ring gear and pinion is pre-run and marked on the pinion face with its proper depth setting called the "Checking Distance" (See Fig. 1). This dimension is from the face of the pinion to the axle center-line. A setting tool must be used to measure the checking distance. Pinion depth is adjusted by adding or subtracting shim thickness. Stay +/- .002 of the pinion dimension (See Fig. 2).

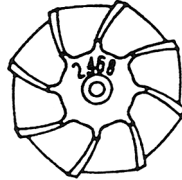

Fig. 1

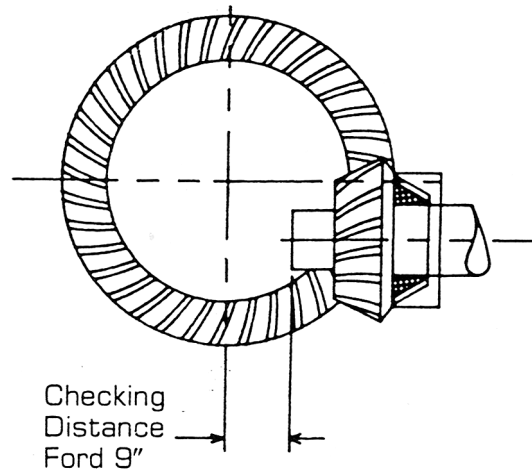

Fig. 2

- STEP 11:** Once pinion depth is achieved using a new crush collar or preload shim pack (Dana) set pinion bearing preload 15 in./lbs. rotating torque with used bearings, and 25 in./lbs. with new bearings. Once preload is set, install the seal and loctite pinion nut.
- STEP 12:** Once the pinion gear is installed, position ring gear and carrier into housing. Ford Racing ring gear and pinions are developed to be run at .008" to .012" backlash for street gear sets.
- STEP 13:** Adjustments for backlash are done by spanner rings in the housing or shim packs behind the carrier bearing cups (GM) or cones (Dana). Always be sure carrier bearings are preloaded. The carrier should not fall out of the housing, but should have to be "tapped" in during final installation. Replace bearing caps and torque to factory specifications.

NO PART OF THIS DOCUMENT MAY BE REPRODUCED WITHOUT PRIOR AGREEMENT AND WRITTEN PERMISSION OF FORD RACING PERFORMANCE PARTS.

**STEP 14:** You are now ready to verify the tooth contact pattern. A gear-marking compound should be used. Paint gear teeth with compound in several spots and rotate ring gear several revolutions. A tooth contact pattern will appear and should be similar to the pattern shown in Fig. 3. If the pattern is not in the approximate position shown, reset pinion depth and backlash to correct pattern. Pinion shims usually must be moved in .003" increments to notice a pattern change. If a pattern is heavy toe, subtract shims (See fig 4). If a pattern is heavy heel, add shims (See fig 5).

**Note:** Reverse this procedure for 8" and 9" Ford.

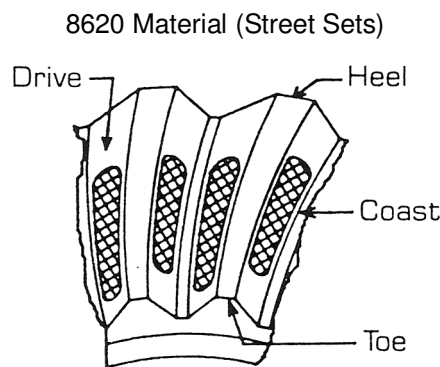

**Correct Load Pattern**  
 Fig. 3

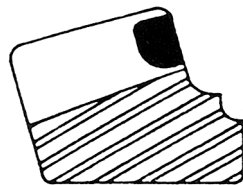

**Incorrect Pattern (Coast Side)**  
 Fig. 4

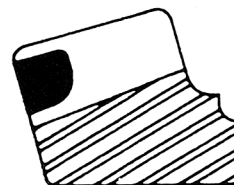

**Incorrect Pattern (Drive side)**  
 Fig. 5

**STEP 15:** Fill the case with required amount of EP85-90 gear lube, and maintain the proper level at all times. Proper maintenance is a must to protect your safety and the working life of your gear set.



# M-4209-G430M Ring and Pinion Set INSTALLATION INSTRUCTIONS

NO PART OF THIS DOCUMENT MAY BE REPRODUCED WITHOUT PRIOR AGREEMENT AND WRITTEN PERMISSION OF FORD RACING PERFORMANCE PARTS.

Properly designed, manufactured and maintained Ford Racing ring gear and pinions, correctly assembled by you in a clean, rigid gear box, and operated with the proper lubricant, should result in safe and satisfactory performance. Be sure application of your gear set is a correct one.

## TORQUE SPECIFICATIONS

### Ring Gear Bolts

3/8" x 7/8" RH - 55-60 ft./lbs.  
3/8" x 3/4" RH - 45-50 ft./lbs.  
3/8" All LH - 45-50 ft./lbs.  
7/16" All - 60-65 ft./lbs.  
1/2" All - 100-110 ft./lbs.

### Carrier Cap Bolts

7/16" (5/8" head) - 60-65 ft./lbs.  
1/2" (3/4" head) - 80-85 ft./lbs.

Factory Ford shop manuals are available from Helm Publications, 1-800-782-4356