



NO PART OF THIS DOCUMENT MAY BE REPRODUCED WITHOUT PRIOR AGREEMENT AND WRITTEN PERMISSION OF FORD PERFORMANCE RACING PARTS.

Please visit www.fordperformanceracingparts.com for the most current instruction information

**!!! PLEASE READ ALL OF THE FOLLOWING INSTRUCTIONS CAREFULLY PRIOR TO INSTALLATION.
AT ANY TIME YOU DO NOT UNDERSTAND THE INSTRUCTIONS, PLEASE CALL THE FORD RACING
TECHLINE AT 1-800-367-3788 !!!**

NOTICE: Suspension fasteners are critical parts that affect the performance of vital components and systems. Failure of these fasteners may result in major service expense. Use the same or equivalent parts if replacement is necessary. Do not use a replacement part of lesser quality or substitute design. Tighten fasteners as specified.

NOTICE: Do **NOT** discard any fasteners unless specifically instructed to do so **IN WRITING**. Use the supplied Red Loc-Tite to ensure fastener locking during installation.

1. Remove the front strut assemblies and front sway bar

1.1 Remove the wheel and tire.

1.2 Remove the front stabilizer bar link upper nut and separate the front stabilizer bar link from the strut and spring assembly. Dispose of the nuts.

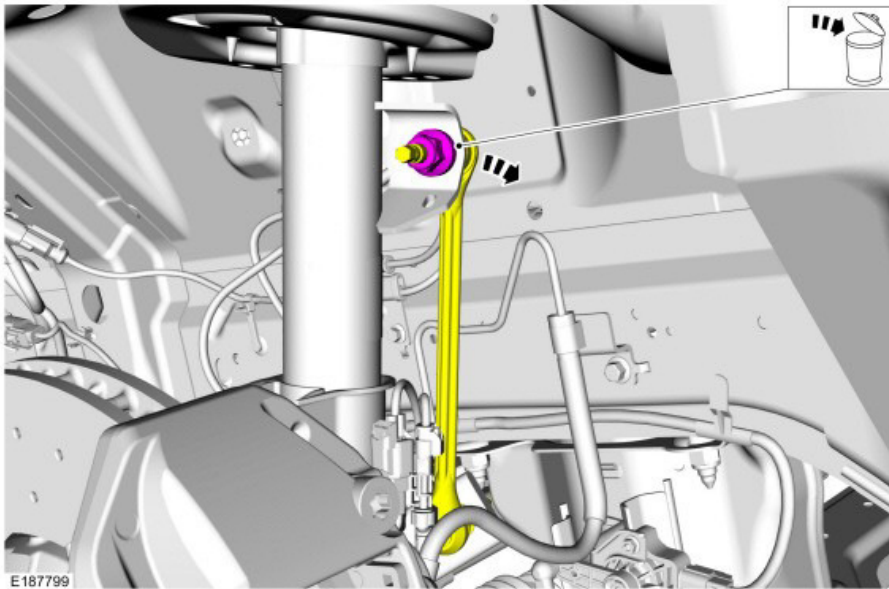

1.3

1.3.1 If equipped.

Remove the wire harness bracket bolt and position the bracket and wire harness aside.

1.3.2 Disconnect the 2 wheel speed sensor retainers and the 1 wire harness retainer.



NO PART OF THIS DOCUMENT MAY BE REPRODUCED WITHOUT PRIOR AGREEMENT AND WRITTEN PERMISSION OF FORD PERFORMANCE RACING PARTS.

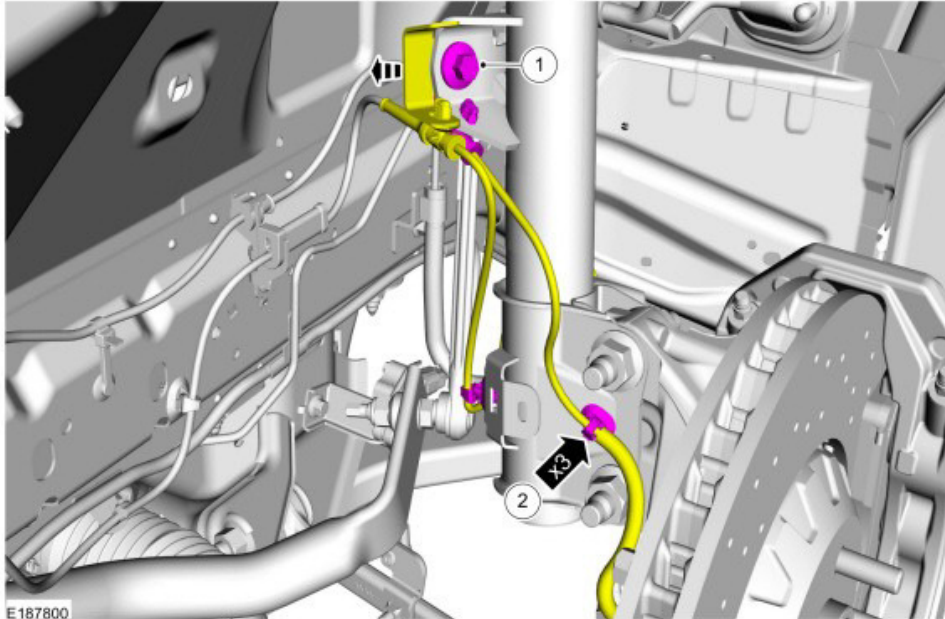

1.4

1.4.1 If equipped.

Disconnect the brake sensor electrical connector.

1.4.2 If equipped.

Disconnect the wire harness connector.

1.4.3 If equipped.

Unclip the brake sensor electrical connector and the 2 wire retainers from the strut.

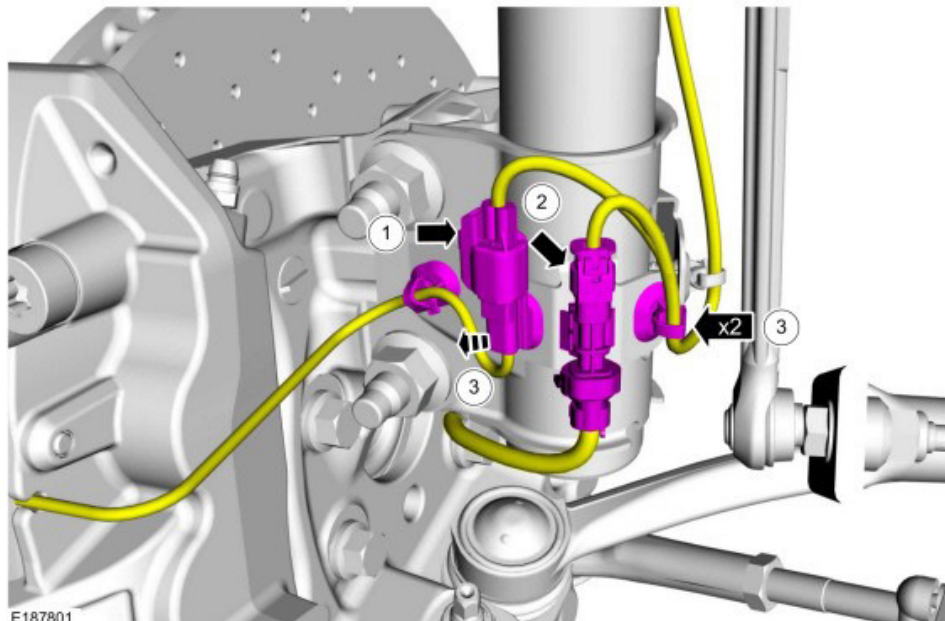



NO PART OF THIS DOCUMENT MAY BE REPRODUCED WITHOUT PRIOR AGREEMENT AND WRITTEN PERMISSION OF FORD PERFORMANCE RACING PARTS.

1.5 Position aside the brake caliper assembly.

NOTE: Base brakes shown, other applications similar.

1.5.1 Remove the 2 brake caliper anchor plate bolts.

1.5.2 Position aside the brake caliper assembly.

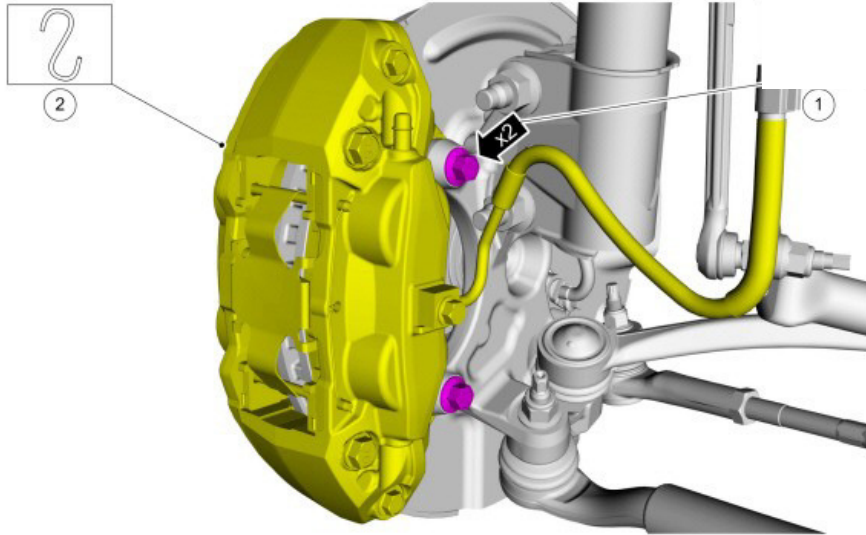

E190443

1.6

1.6.1 NOTE: Original strut-to-wheel spindle bolts are splined and may need to be driven out. Remove the 2 strut-to-wheel spindle bolts and nuts. Dispose of the nuts.

1.6.2 Separate the wheel spindle from the front strut and spring assembly.

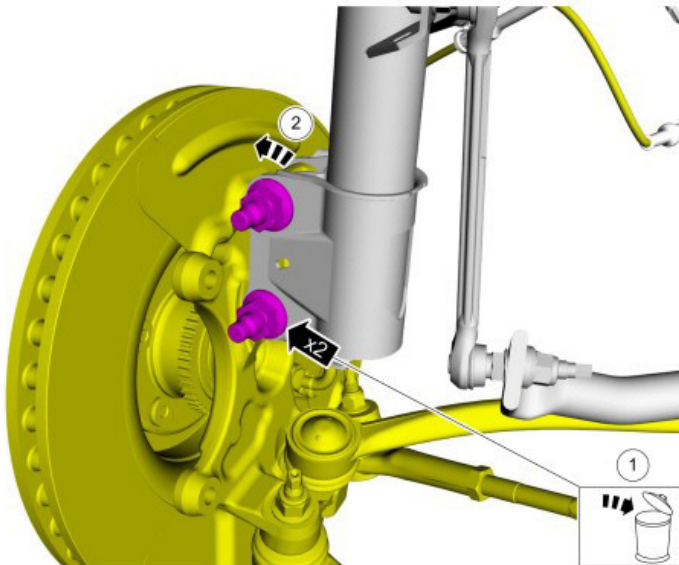

E187802



NO PART OF THIS DOCUMENT MAY BE REPRODUCED WITHOUT PRIOR AGREEMENT AND WRITTEN PERMISSION OF FORD PERFORMANCE RACING PARTS.

1.7

1.7.1 Remove and discard the 3 upper strut mount nuts.

1.7.2 Remove the front strut and spring assembly.

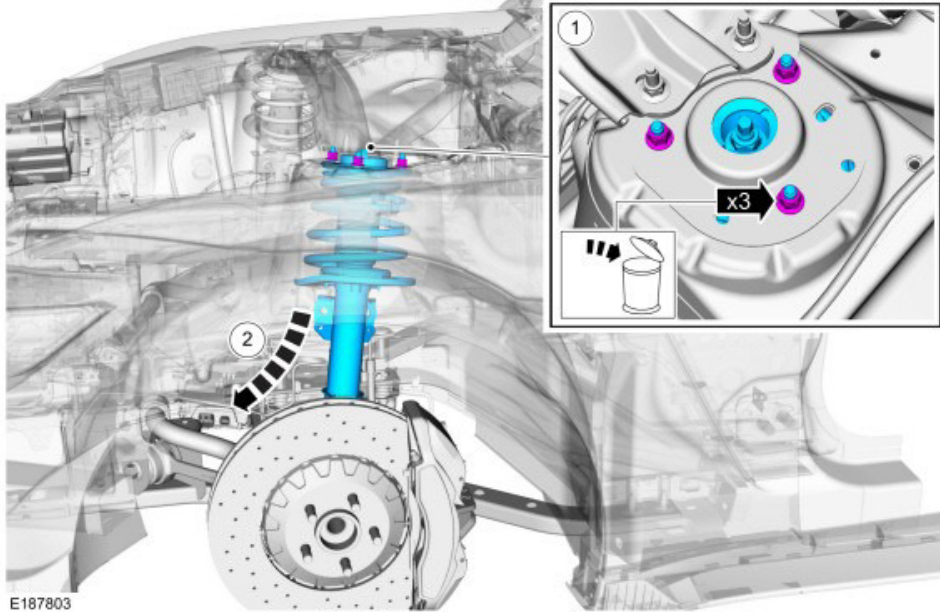

1.8 Remove Air Cleaner

1.8.1 Loosen the clamp, position aside the air outlet pipe.

Torque: 48 lb.in (5.4 Nm)

1.8.2 Detach the wiring harness retainers and disconnect the MAF sensor electrical connectors.

1.8.3 Remove the bolt.

Torque: 71 lb.in (8 Nm)

1.8.4 Remove the air cleaner assembly.

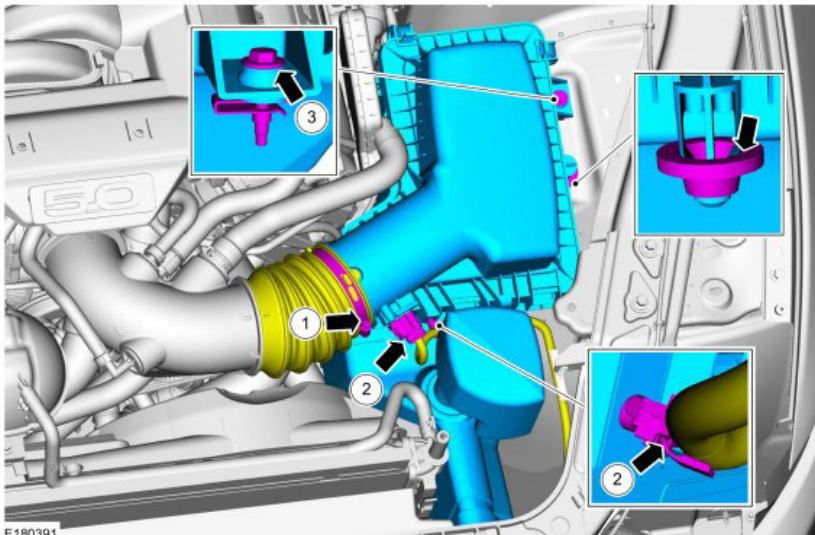

Factory Ford shop manuals are available from Helm Publications, 1-800-782-4356 Or www.helminc.com



NO PART OF THIS DOCUMENT MAY BE REPRODUCED WITHOUT PRIOR AGREEMENT AND WRITTEN PERMISSION OF FORD PERFORMANCE RACING PARTS.

1.9

1.9.1 Remove both passenger-side stabilizer bar bracket bolts and car-forward driver side stabilizer bar bracket bolt approaching from the engine bay. Passenger side bolts pictured below for 5.0L vehicles, 2.3L vehicles will be similar.

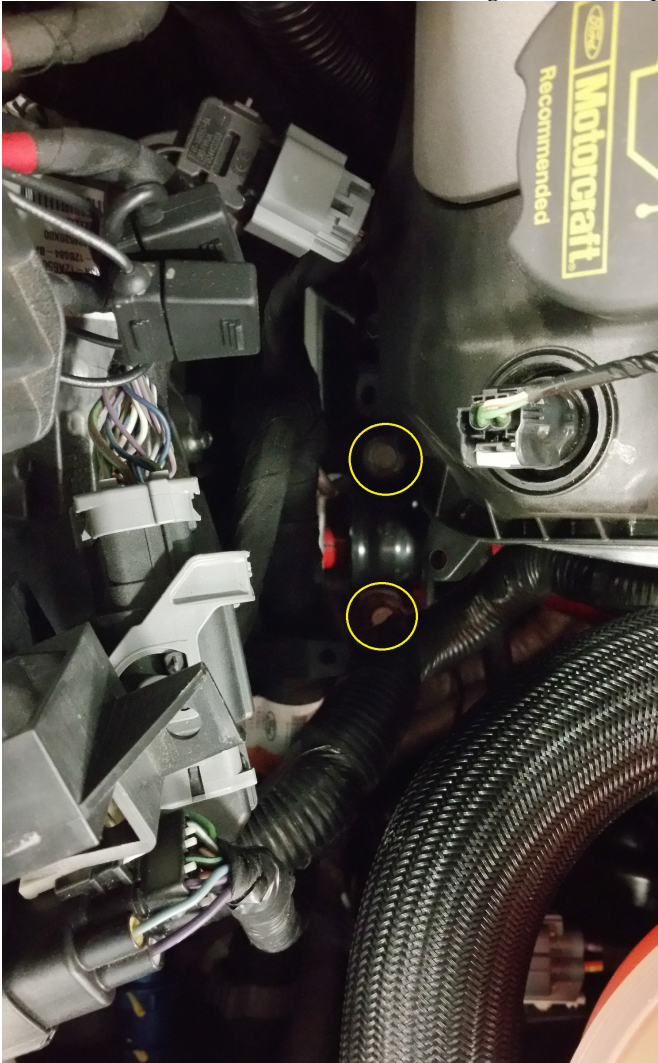

1.9.2 Remove car-rearward driver side stabilizer bar bracket bolt from driver side wheel well.

1.10

1.10.1 NOTE: The stabilizer bar links are designed with low friction ball joints that have a low breakaway torque.
NOTE: Use the hex-holding feature to prevent the ball stud from turning while removing the stabilizer bar link nut.
Remove and discard the 2 front stabilizer bar link lower nuts and position aside the front stabilizer bar links.



NO PART OF THIS DOCUMENT MAY BE REPRODUCED WITHOUT PRIOR AGREEMENT AND WRITTEN PERMISSION OF FORD PERFORMANCE RACING PARTS.

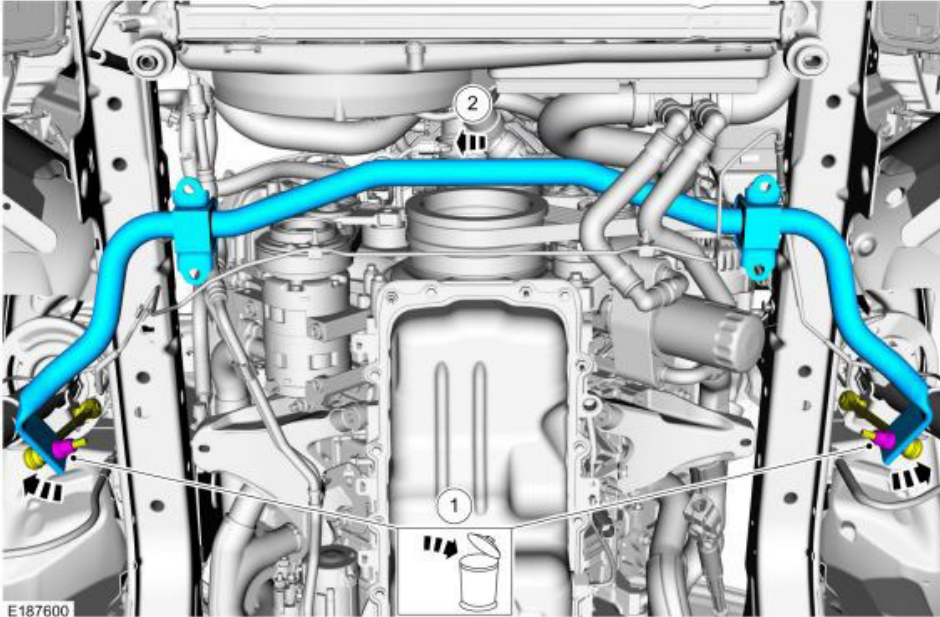

- 1.11
- 1.11.1 Carefully remove the stabilizer bar through driver side wheel well. It is important to use caution and finesse to avoid damaging other components.

2. Install the new Ford Performance front strut assemblies and front sway bar

- 2.1 Position the new front stabilizer bar.
- 2.2
- 2.2.1 NOTE: Use the hex-holding feature to prevent the ball stud from turning while installing the stabilizer bar link nut.
- 2.2.2 Position the front stabilizer bar links and install the 2 new front stabilizer bar link lower nuts (W712503-S440).
Torque: 85 lb.ft (115 Nm)

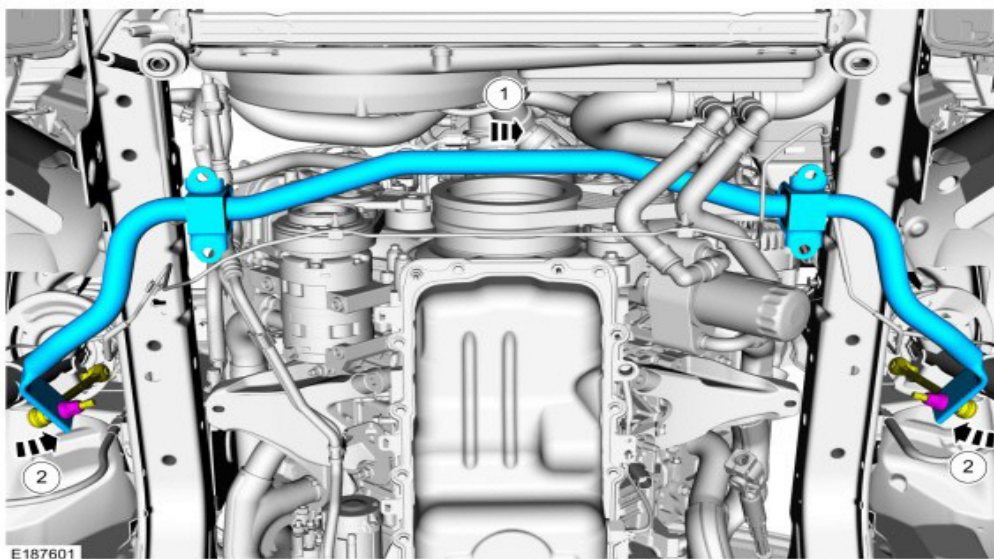

Factory Ford shop manuals are available from Helm Publications, 1-800-782-4356 Or www.helminc.com



NO PART OF THIS DOCUMENT MAY BE REPRODUCED WITHOUT PRIOR AGREEMENT AND WRITTEN PERMISSION OF FORD PERFORMANCE RACING PARTS.

2.3 Position the new brackets over the bushings. Apply Loc-Tite to bolts and tighten to torque.

Torque: 76 lb.ft (103 Nm)

2.4 Re-install air box. To install, reverse removal procedure.

2.5

2.5.1 Install the front strut and spring assembly. Ensure that notch in strut top mount is facing towards engine bay

2.5.2 Install the 3 new upper strut mount nuts.

Torque: 46 lb.ft (63 Nm)

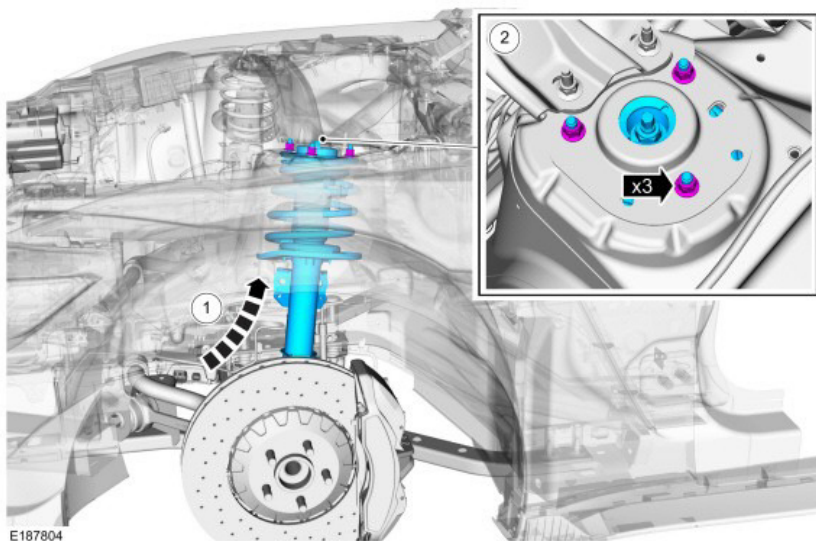

2.6

2.6.1 Attach the wheel spindle to the front strut and spring assembly.

2.6.2 Install the 2 strut-to-wheel spindle bolts and new nuts (W520517-S450)

Torque: 184 lb.ft (250 Nm)

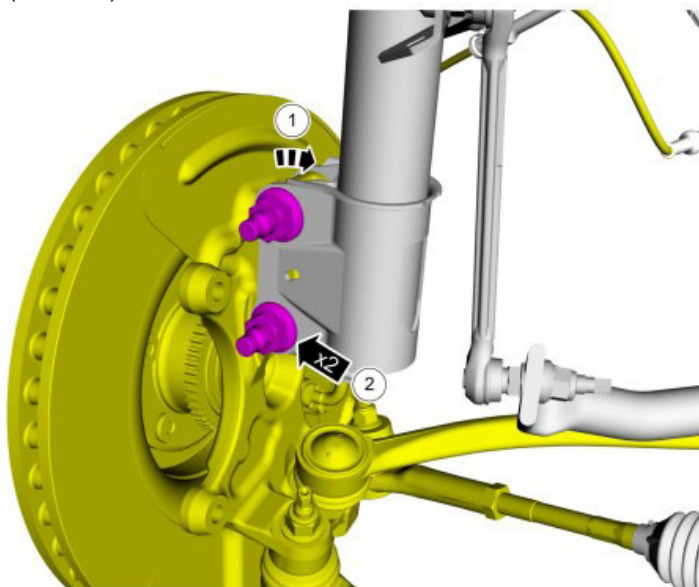

1-800-782-4356 Or www.helminc.com



NO PART OF THIS DOCUMENT MAY BE REPRODUCED WITHOUT PRIOR AGREEMENT AND WRITTEN PERMISSION OF FORD PERFORMANCE RACING PARTS.

2.7 Position the brake caliper assembly and install the 2 brake caliper anchor plate bolts. Apply Loc-Tite to bolts and tighten to torque.

Torque: 85 lb.ft (115 Nm)

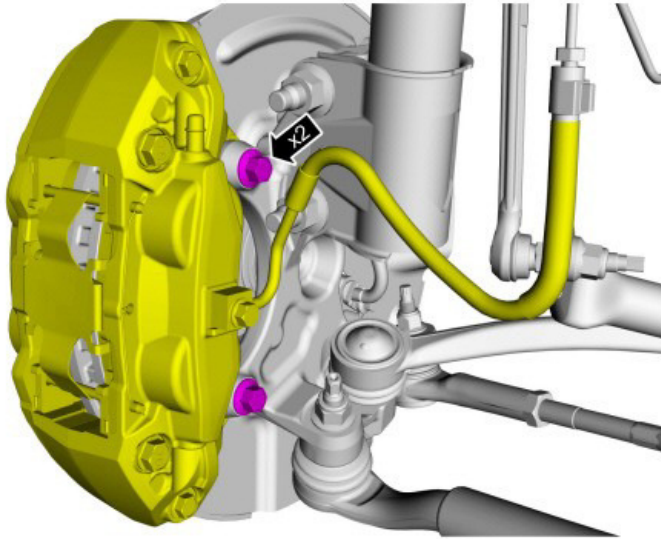

E190444

2.8

2.8.1 If equipped.

Clip the brake sensor electrical connector and the 2 wire retainers to the strut.

2.8.2 If equipped.

Connect the wire harness connector.

2.8.3 If equipped.

Connect the brake sensor electrical connector.

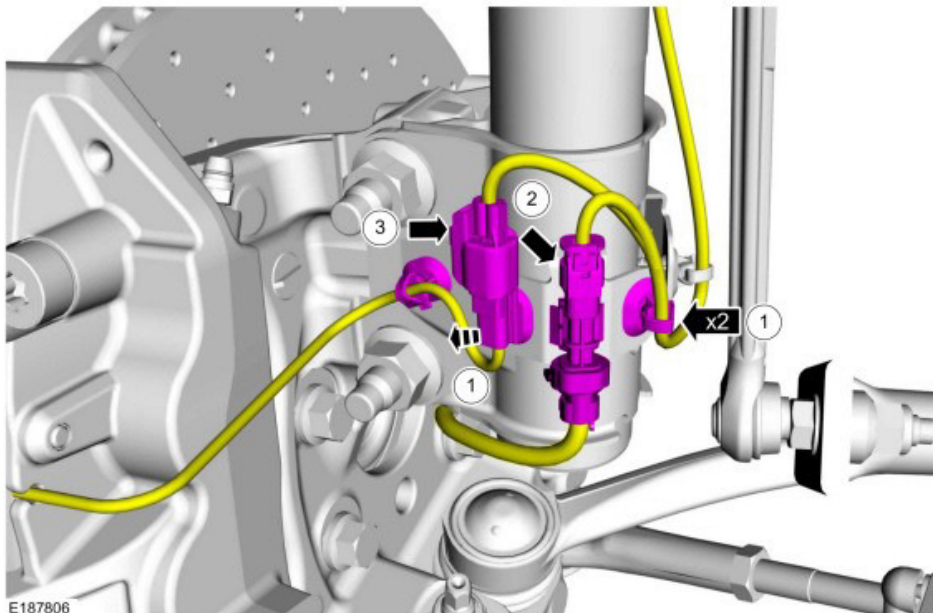

E187806



NO PART OF THIS DOCUMENT MAY BE REPRODUCED WITHOUT PRIOR AGREEMENT AND WRITTEN PERMISSION OF FORD PERFORMANCE RACING PARTS.

2.9

2.9.1 Connect the 2 wheel speed sensor retainers and the 1 wire harness retainer.

2.9.2 If equipped, position the wire harness bracket install the bolt.

Torque: 46 lb.ft (63 Nm)

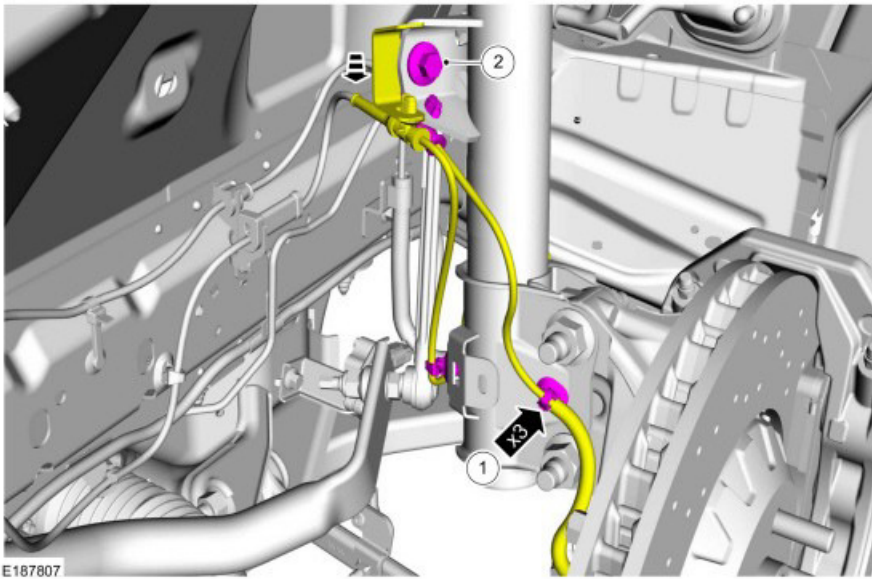

2.10

2.10.1 Position the front stabilizer bar link.

2.10.2 Install the new front stabilizer bar link upper nut (W712503-S440).

Torque: 85 lb.ft (115 Nm)

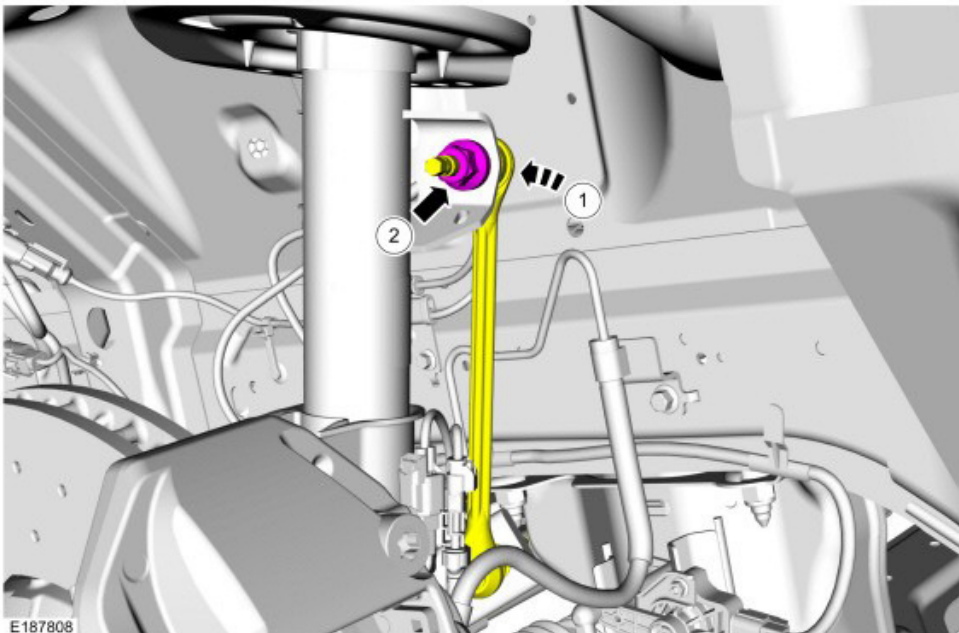



NO PART OF THIS DOCUMENT MAY BE REPRODUCED WITHOUT PRIOR AGREEMENT AND WRITTEN PERMISSION OF FORD PERFORMANCE RACING PARTS.

2.11 Install the wheel and tire, see page 35 for torque specification.

2.12. Set alignment, see page 35.

3. Remove the muffler and tailpipe

3.1 Remove the muffler and tailpipe.

NOTE: Do not excessively bend, twist or allow the exhaust to hang from the flexible joint or damage to the exhaust system may occur.

NOTE: Do not use oil or grease-based lubricants on the isolators. They may cause deterioration of the rubber.

NOTE: Removal steps in this procedure may contain installation details.

3.1.1 With the vehicle in NEUTRAL, position it on a hoist.

3.1.2 Loosen the clamps and separate the muffler and tailpipe from the RH catalytic converter and LH muffler inlet pipe.
Torque: 35 lb.ft (48 Nm)

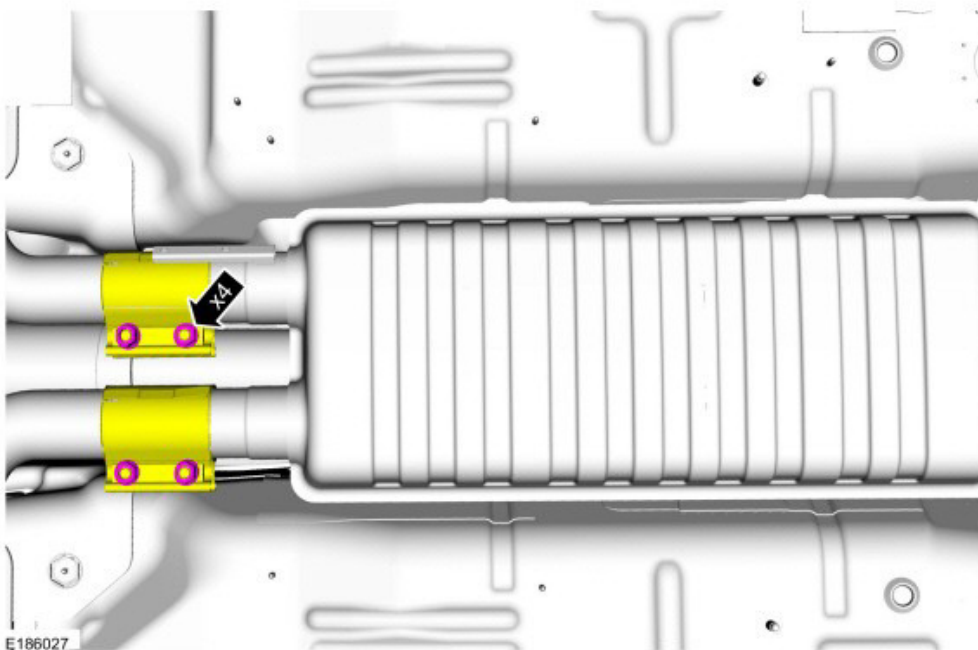

E186027



NO PART OF THIS DOCUMENT MAY BE REPRODUCED WITHOUT PRIOR AGREEMENT AND WRITTEN PERMISSION OF FORD PERFORMANCE RACING PARTS.

3.1.3 Remove the LH and RH rear exhaust hanger isolator bracket bolts. Unhook the rear exhaust hanger isolators and remove the muffler and tailpipe.

Torque: 18 lb.ft (25 Nm)

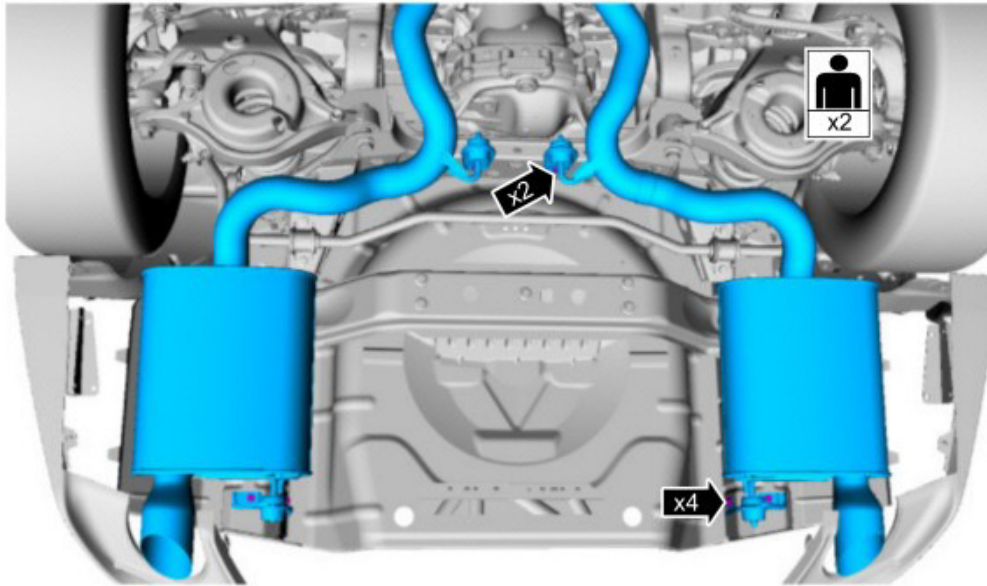

E198946



NO PART OF THIS DOCUMENT MAY BE REPRODUCED WITHOUT PRIOR AGREEMENT AND WRITTEN PERMISSION OF FORD PERFORMANCE RACING PARTS.

4. Remove rear shock absorber

NOTICE: Suspension fasteners are critical parts that affect the performance of vital components and systems. Failure of these fasteners may result in major service expense. Use the same or equivalent parts if replacement is necessary. Do not use a replacement part of lesser quality or substitute design. Tighten fasteners as specified.

4.1 Remove the wheel and tire.

4.2 Support the rear suspension.

Use the General Equipment: Vehicle/Axle Stands

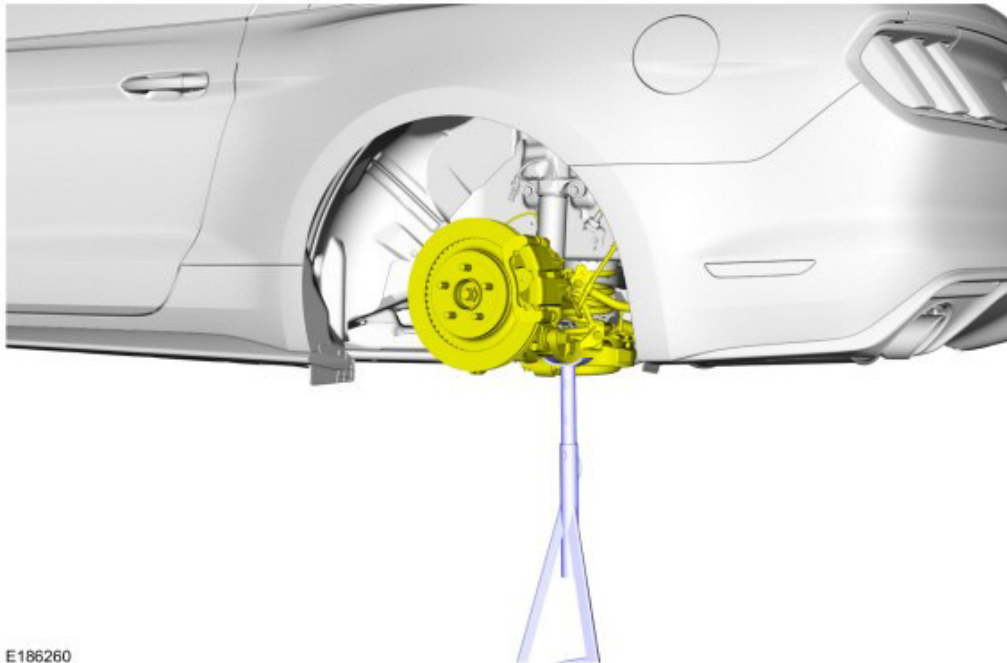

E186260



NO PART OF THIS DOCUMENT MAY BE REPRODUCED WITHOUT PRIOR AGREEMENT AND WRITTEN PERMISSION OF FORD PERFORMANCE RACING PARTS.

4.3 Remove the 2 rear shock absorber lower bolts.

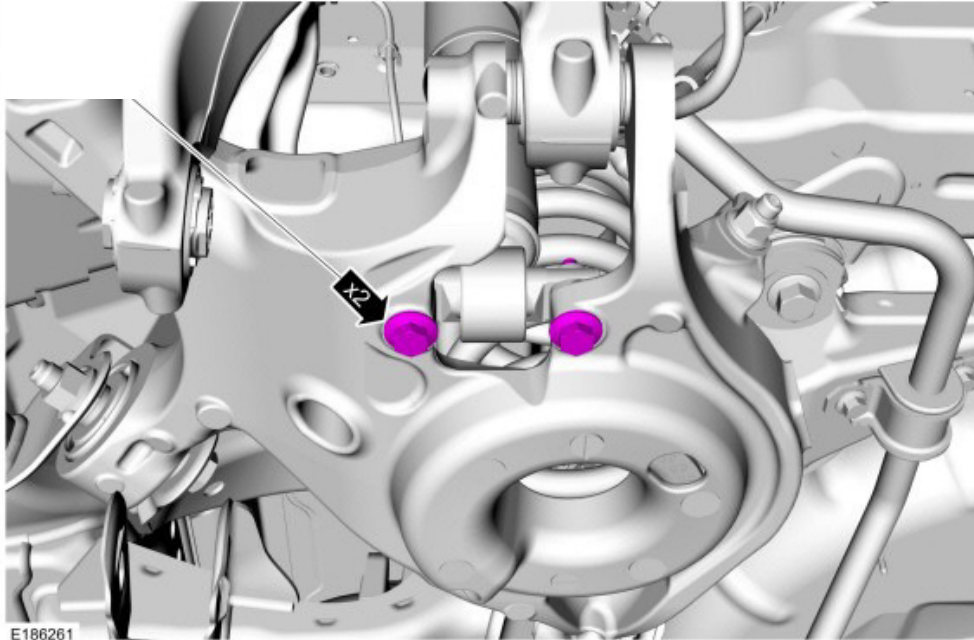

4.4 Remove the 2 rear shock absorber upper bolts and remove the rear shock absorber.

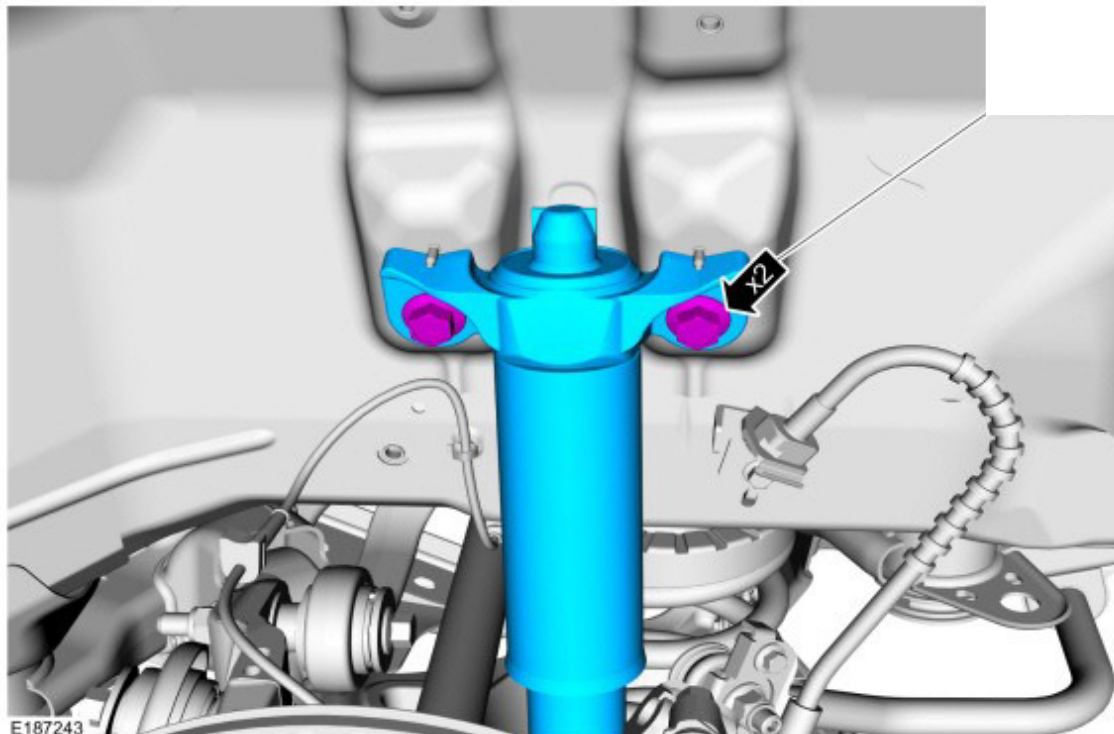

Factory Ford shop manuals are available from Helm Publications, 1-800-782-4356 Or www.helminc.com



NO PART OF THIS DOCUMENT MAY BE REPRODUCED WITHOUT PRIOR AGREEMENT AND WRITTEN PERMISSION OF FORD PERFORMANCE RACING PARTS.

5. Remove the rear brake caliper

NOTICE: Suspension fasteners are critical parts that affect the performance of vital components and systems. Failure of these fasteners may result in major service expense. Use the same or equivalent parts if replacement is necessary. Do not use a replacement part of lesser quality or substitute design. Tighten fasteners as specified.

5.1 Remove the brake discs.

5.1.1 **NOTICE:** Do not allow the brake caliper and anchor plate assembly to hang from the brake hose or damage to the hose may occur.

Remove the 2 bolts and position the brake caliper and anchor plate assembly aside. Utilize a hook or cord to support the brake caliper.

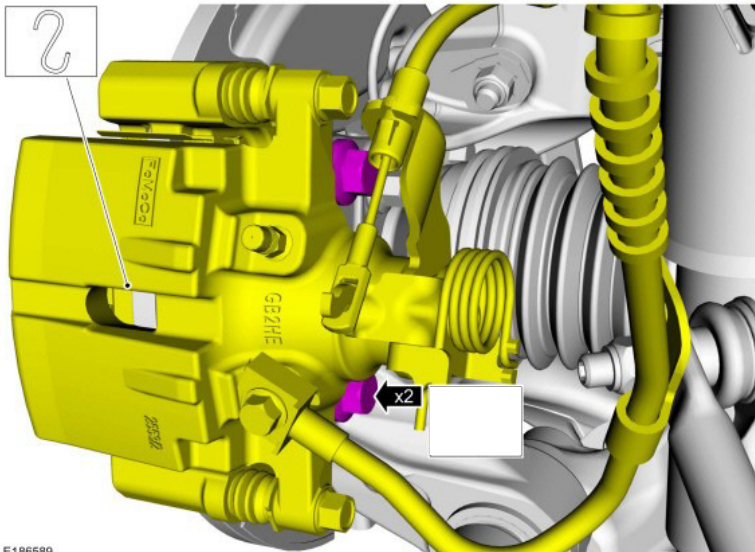

E186589



NO PART OF THIS DOCUMENT MAY BE REPRODUCED WITHOUT PRIOR AGREEMENT AND WRITTEN PERMISSION OF FORD PERFORMANCE RACING PARTS.

5.1.2 Remove the brake rotor.

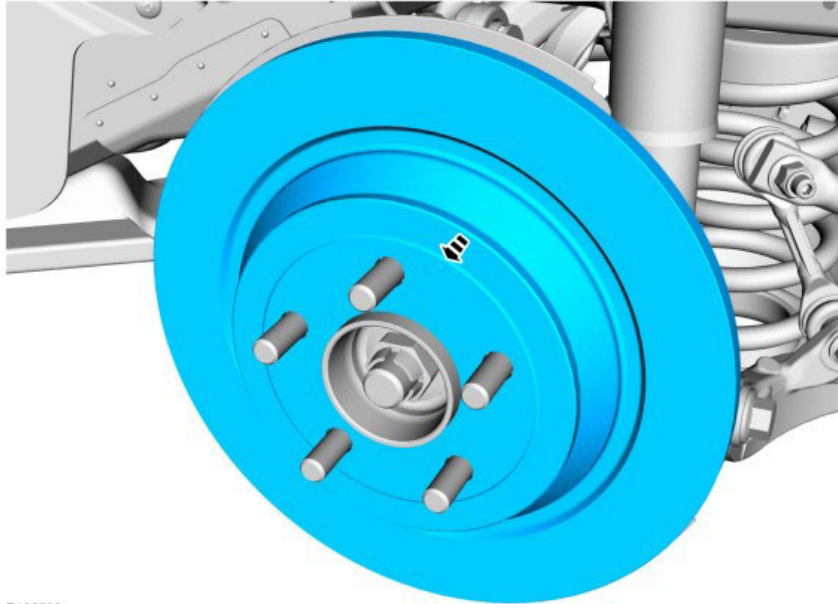

E186590

5.3

5.3.1 Remove the wheel speed sensor bolt and position aside the wheel speed sensor.

5.3.2 Remove the parking brake cable bracket bolt and position the parking brake cable bracket aside.

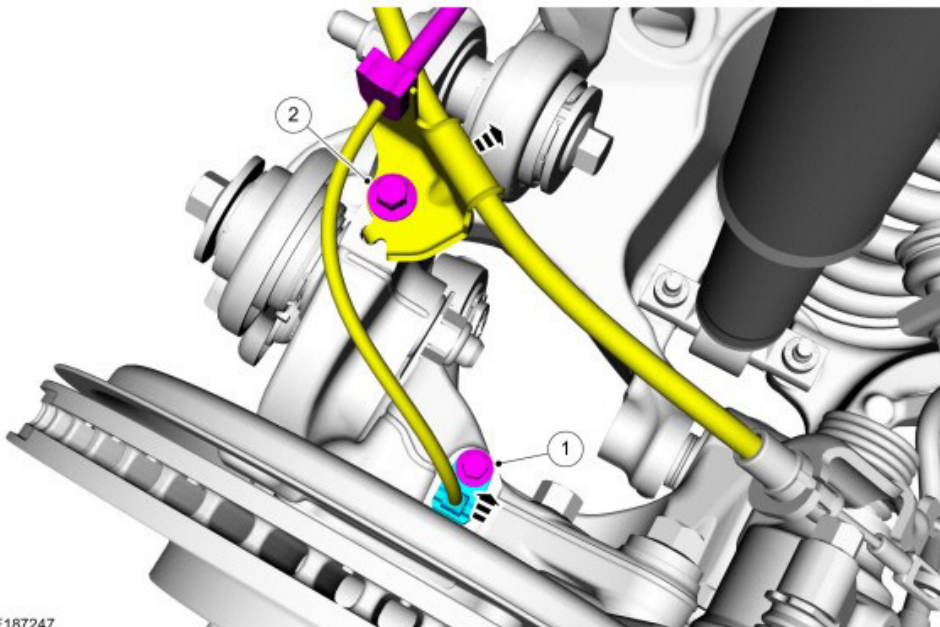

E187247



NO PART OF THIS DOCUMENT MAY BE REPRODUCED WITHOUT PRIOR AGREEMENT AND WRITTEN PERMISSION OF FORD PERFORMANCE RACING PARTS.

6. Remove the rear Toe Link.

NOTICE: Suspension fasteners are critical parts that affect the performance of vital components and systems. Failure of these fasteners may result in major service expense. Use the same or equivalent parts if replacement is necessary. Do not use a replacement part of lesser quality or substitute design. Tighten fasteners as specified.

6.1 Support the suspension at curb height.

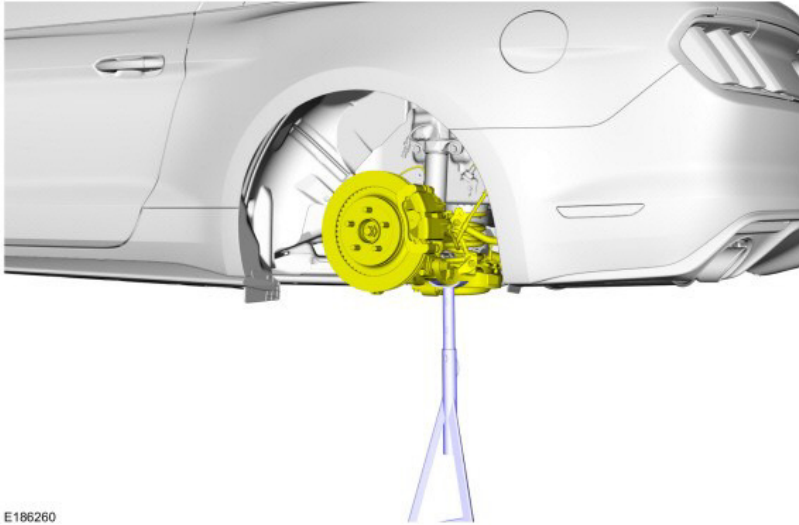

E186260

6.2

6.2.1 Index mark both the inner and outer cam wheels for use during assembly.

6.2.2 Remove the toe link-to-knuckle bolt, the toe link-to-frame bolt and nut and remove the toe link. Discard the nut.

NOTE: To ease assembly and alignment, with a paint pen make alignment marks for the cams.

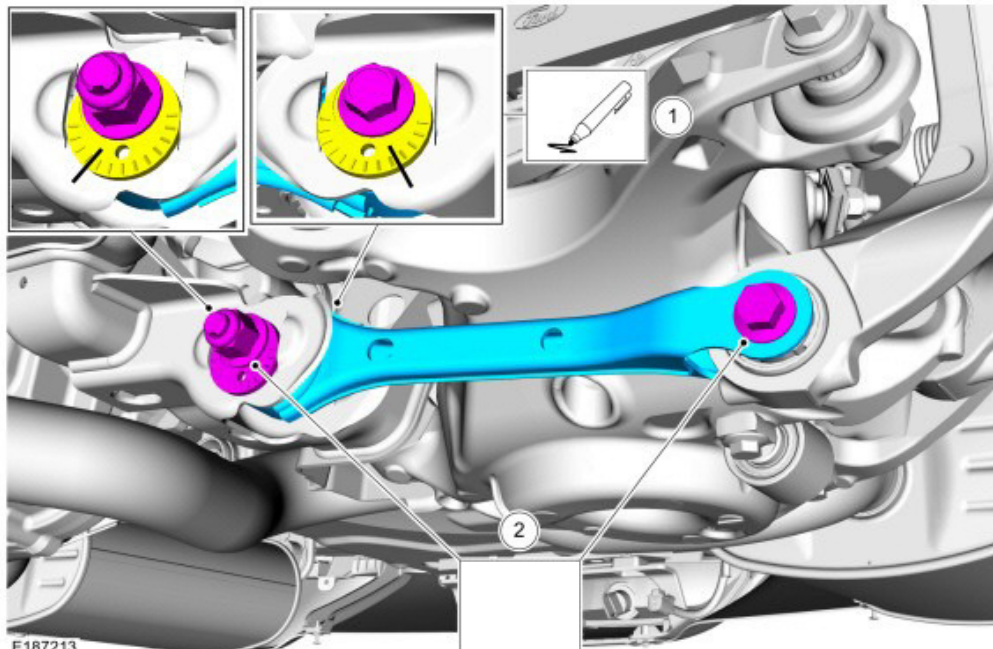

E187213



NO PART OF THIS DOCUMENT MAY BE REPRODUCED WITHOUT PRIOR AGREEMENT AND WRITTEN PERMISSION OF FORD PERFORMANCE RACING PARTS.

7. Remove the lower arm.

NOTICE: Suspension fasteners are critical parts that affect the performance of vital components and systems. Failure of these fasteners may result in major service expense. Use the same or equivalent parts if replacement is necessary. Do not use a replacement part of lesser quality or substitute design. Tighten fasteners as specified.

7.1 Support the suspension at curb height.

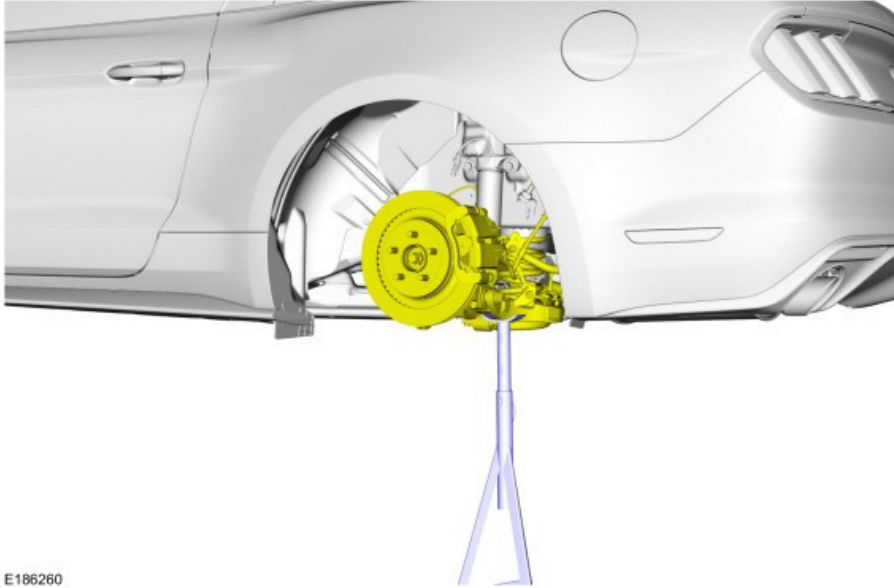

E186260

7.2

NOTE: The stabilizer bar links are designed with low friction ball joints that have a low breakaway torque.

NOTE: Use the hex-holding feature to prevent the ball stud from turning while removing the stabilizer bar link nut.

Remove the stabilizer bar link upper nut and position the stabilizer bar link aside. Discard the nut. It is not necessary to remove the lower nut.

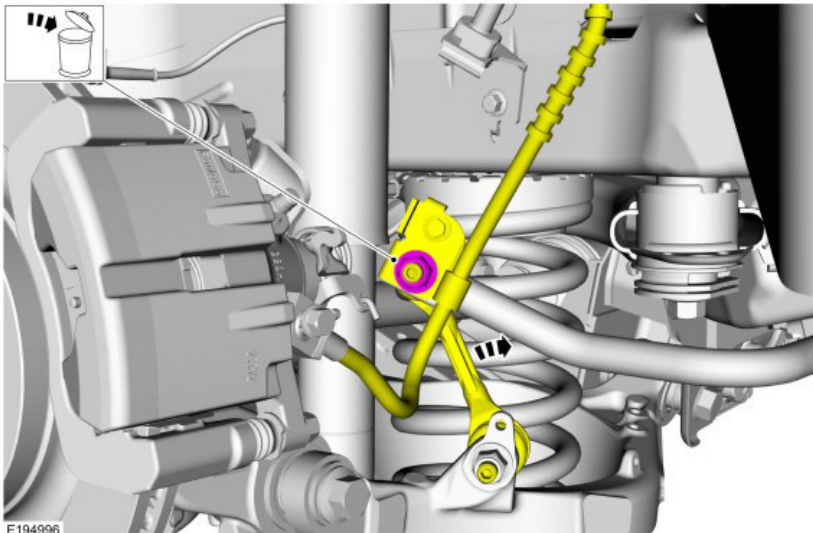

E194996



NO PART OF THIS DOCUMENT MAY BE REPRODUCED WITHOUT PRIOR AGREEMENT AND WRITTEN PERMISSION OF FORD PERFORMANCE RACING PARTS.

7.3 Remove the lower integral link bolt (labeled 2 below). The upper bolt does not need to be removed.

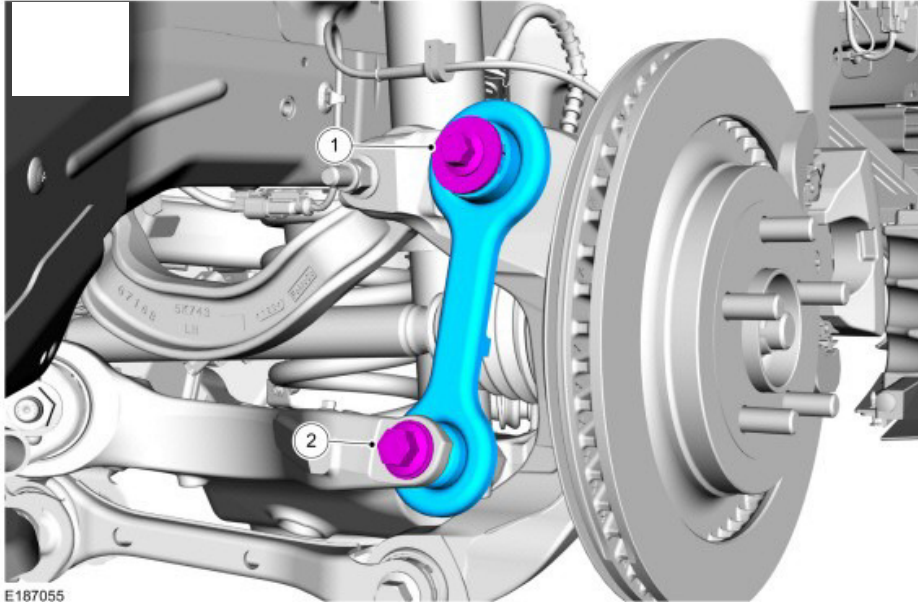

7.4 Remove the forward lower control arm-to-frame bolt.

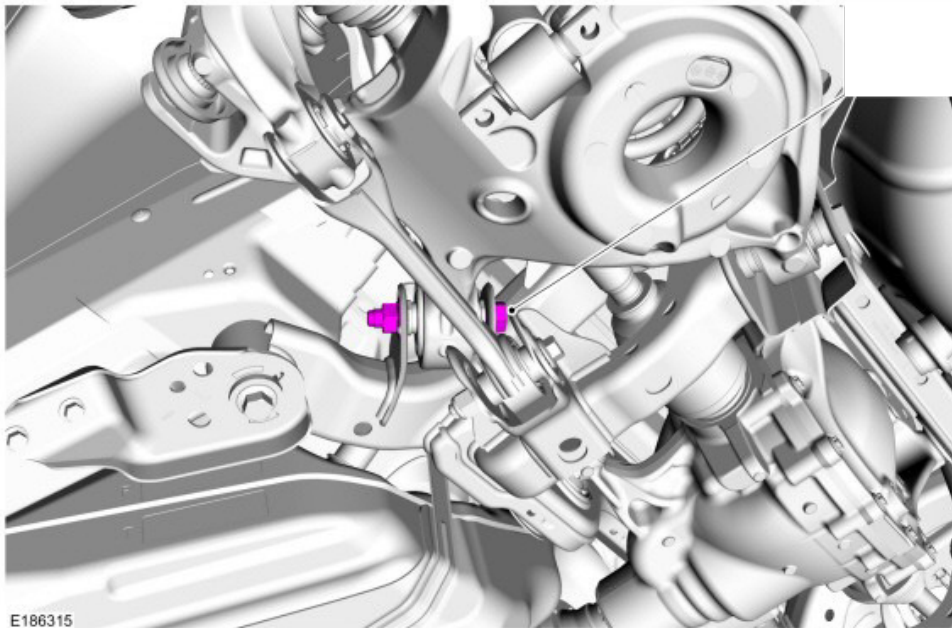



NO PART OF THIS DOCUMENT MAY BE REPRODUCED WITHOUT PRIOR AGREEMENT AND WRITTEN PERMISSION OF FORD PERFORMANCE RACING PARTS.

7.5

7.5.1 Support the coil spring.

7.5.2 Remove the rearward lower control arm-to-frame bolt.

7.5.3 NOTE: After removing the lower arm, the spindle will be unsupported. Ensure that the spindle is supported by a hook or cord prior to removing the arm.

Remove the lower control arm.

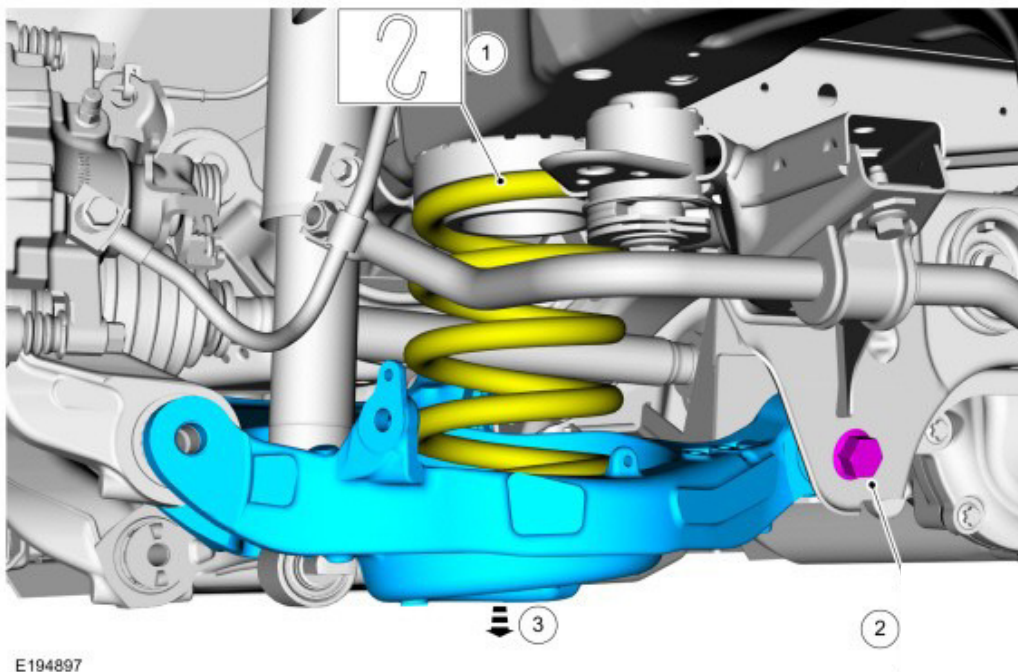



NO PART OF THIS DOCUMENT MAY BE REPRODUCED WITHOUT PRIOR AGREEMENT AND WRITTEN PERMISSION OF FORD PERFORMANCE RACING PARTS.

8. Remove the spring.

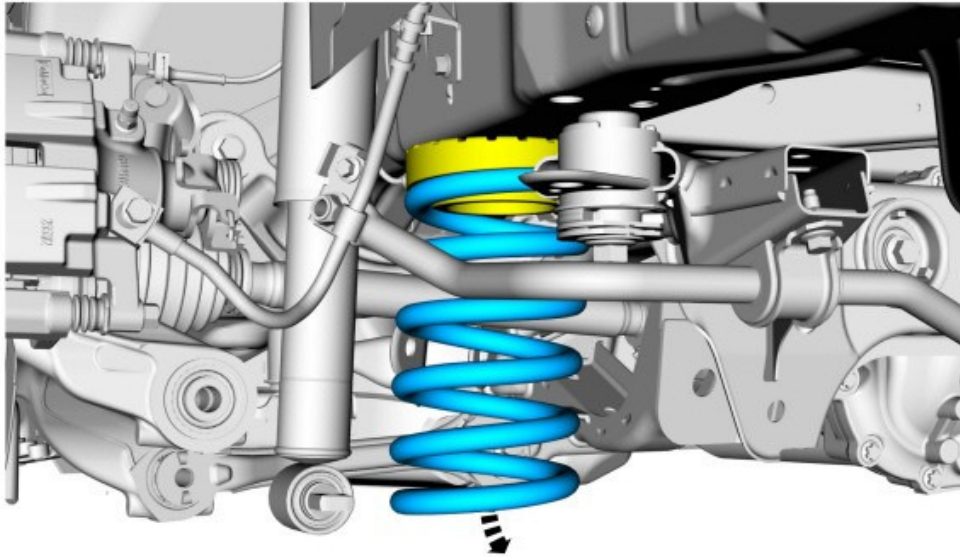

E195073

9. Replace Toe Bearing in the Rear Knuckles

9.1 Set up your ball joint press. (See below) Use a 1 1/4" socket to push out the bushing.





NO PART OF THIS DOCUMENT MAY BE REPRODUCED WITHOUT PRIOR AGREEMENT AND WRITTEN PERMISSION OF FORD PERFORMANCE RACING PARTS.



9.2 With the old bushing removed, set up your ball joint press with new bearing to press in knuckle.





**FORD PERFORMANCE
PARTS**

M-FR3A-M8 Handling Pack Installation Guide

Updated September 2015

NO PART OF THIS DOCUMENT MAY BE REPRODUCED WITHOUT PRIOR AGREEMENT AND WRITTEN PERMISSION OF FORD PERFORMANCE RACING PARTS.



9.3 Press in new bearing and ensure bearing is centered in knuckle.
NOTE: Use Red Loctite on bearing mating surface.



Factory Ford shop manuals are available from Helm Publications, 1-800-782-4356 Or www.helminc.com



NO PART OF THIS DOCUMENT MAY BE REPRODUCED WITHOUT PRIOR AGREEMENT AND WRITTEN PERMISSION OF FORD PERFORMANCE RACING PARTS.

10. Install the new Ford Performance spring

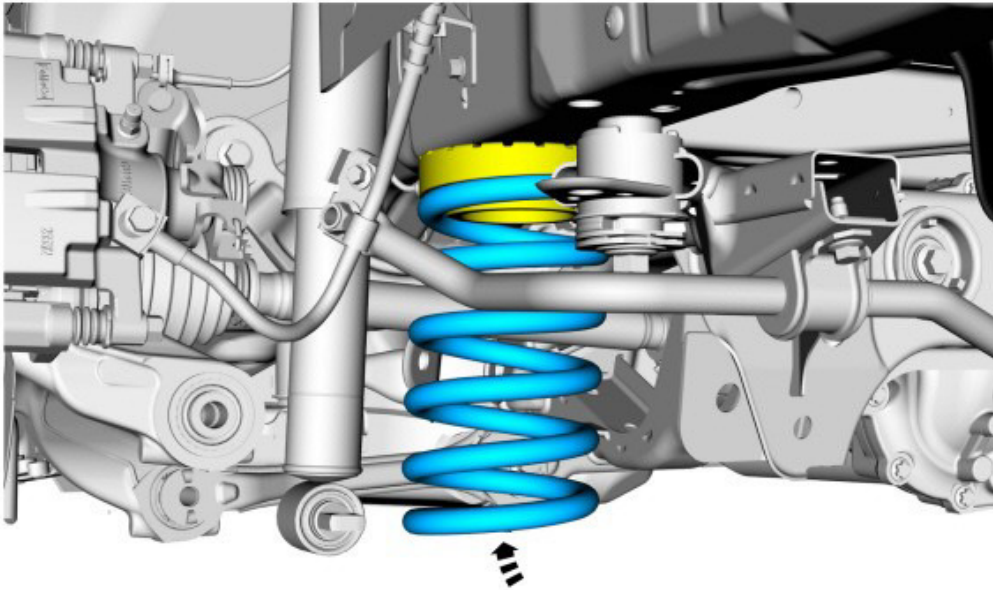

E195074

10.1 Make sure that the spring is correctly located in the upper spring seat.

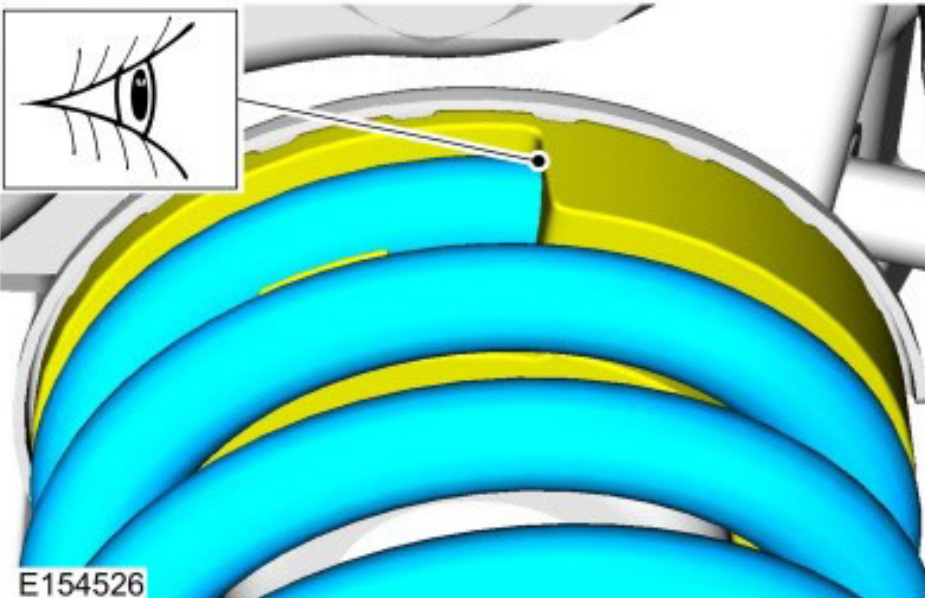

E154526



NO PART OF THIS DOCUMENT MAY BE REPRODUCED WITHOUT PRIOR AGREEMENT AND WRITTEN PERMISSION OF FORD PERFORMANCE RACING PARTS.

11. Install the lower arm

11.1 Inspect the lower coil spring seat. Make sure it is properly aligned in the lower control arm.

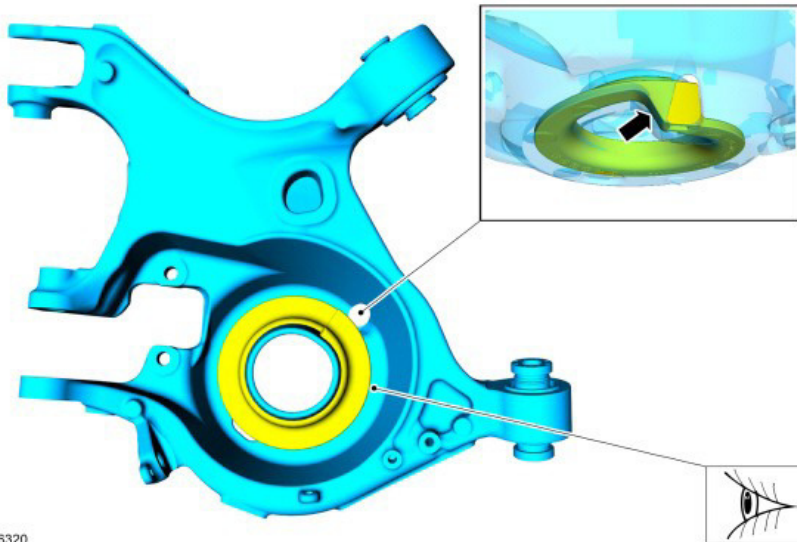

E186320

11.2

11.2.1 Position the lower control arm.

11.2.2 Apply Loc-Tite and install the rearward lower control arm-to-frame bolt.

NOTE: Only tighten the bolt finger tight at this stage.

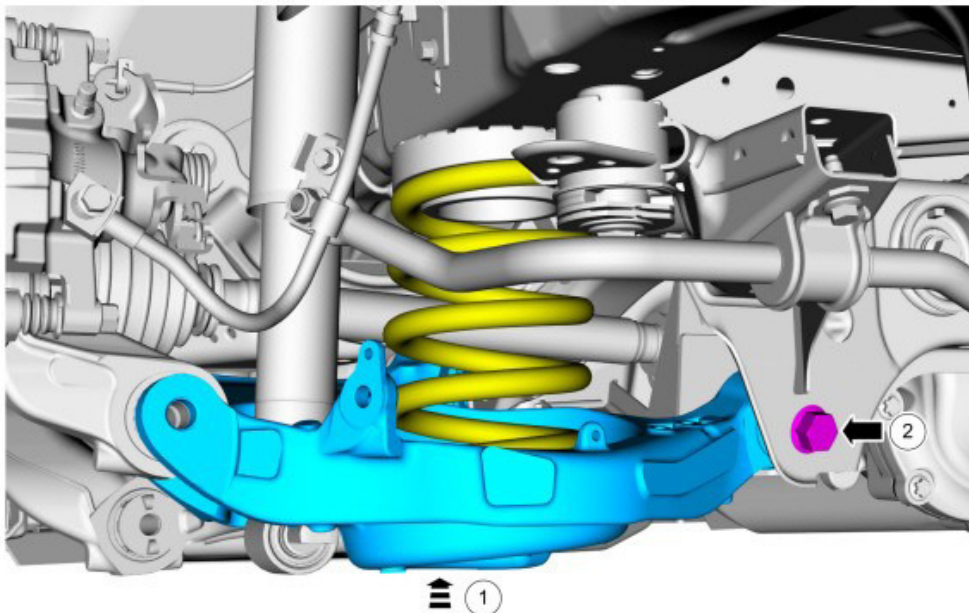

E194898



NO PART OF THIS DOCUMENT MAY BE REPRODUCED WITHOUT PRIOR AGREEMENT AND WRITTEN PERMISSION OF FORD PERFORMANCE RACING PARTS.

- 11.3 Make sure that the coil spring is properly positioned in the lower coil spring seat.

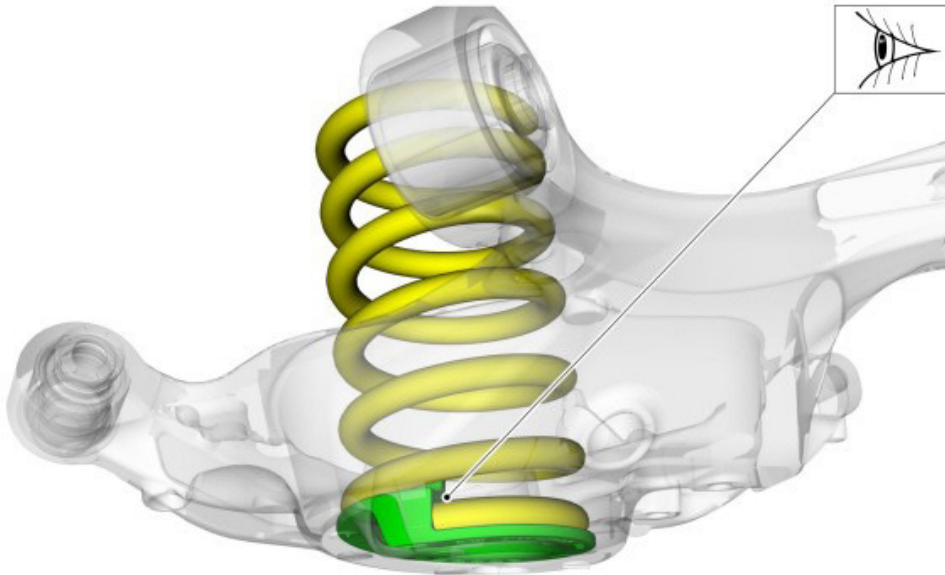

E190448

- 11.4 Apply Loc-Tite and install the forward lower control arm-to-frame bolt.
NOTE: Only tighten the bolt finger tight at this stage.

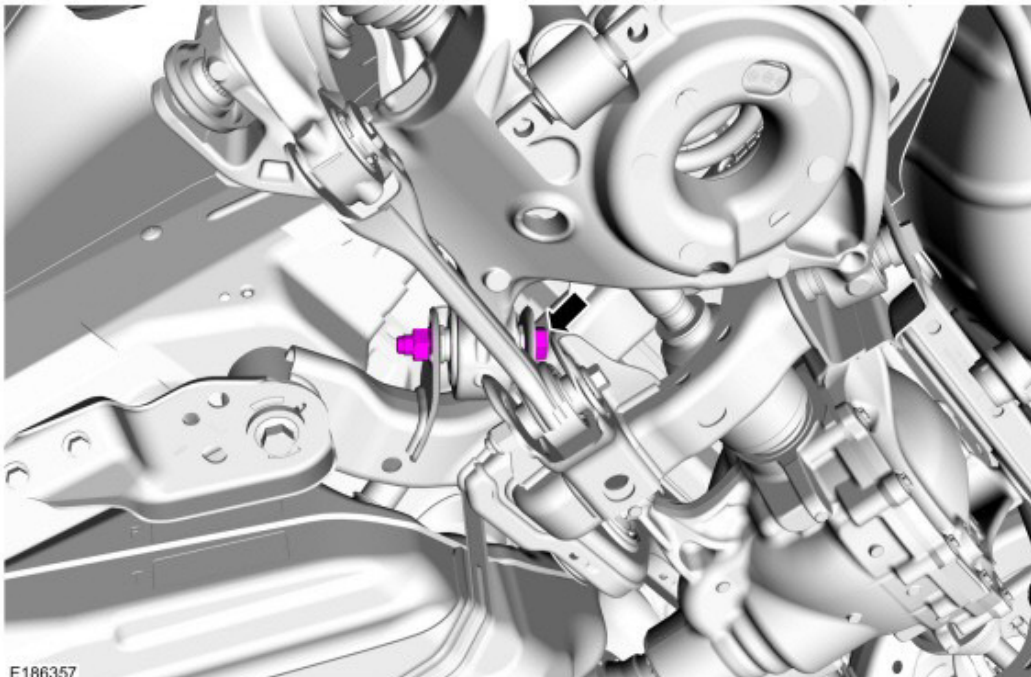

E186357



NO PART OF THIS DOCUMENT MAY BE REPRODUCED WITHOUT PRIOR AGREEMENT AND WRITTEN PERMISSION OF FORD PERFORMANCE RACING PARTS.

12. Install the new Ford Performance Rear Shock Absorber

12.1 Install the new rear shock absorber and install the 2 rear shock absorber lower bolts. Apply Loc-Tite to bolts and tighten to torque. Torque: 35 lb.ft (48 Nm)

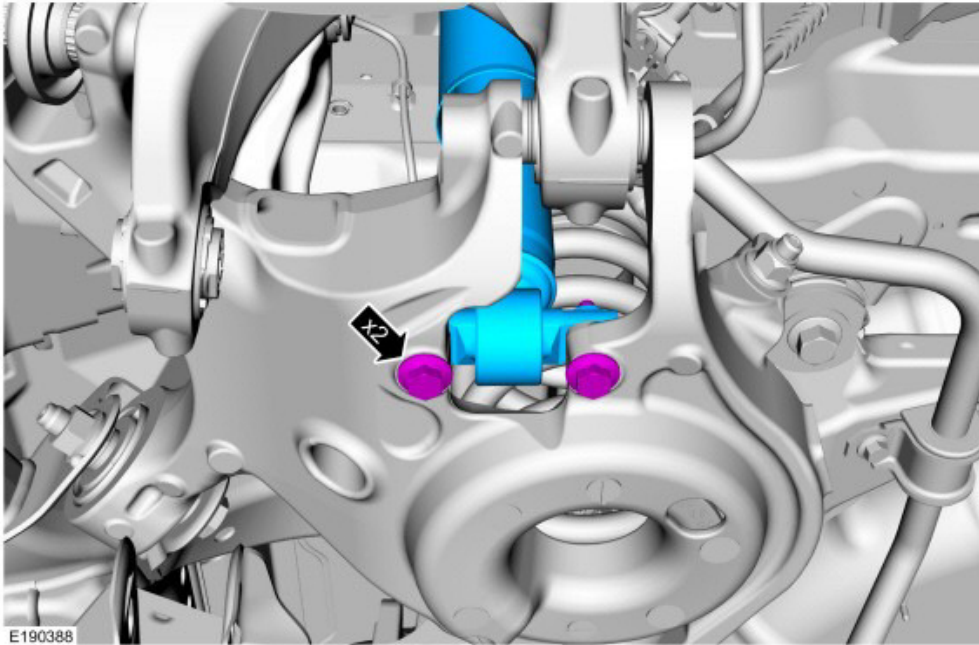

12.2

12.2.1 Compress the rear shock absorber and align the rear shock absorber upper mount under the body alignment pins.

12.2.2 Install the 2 rear shock absorber upper bolts. Apply Loc-Tite to bolts and tighten to torque. Torque: 66 lb.ft (90 Nm)

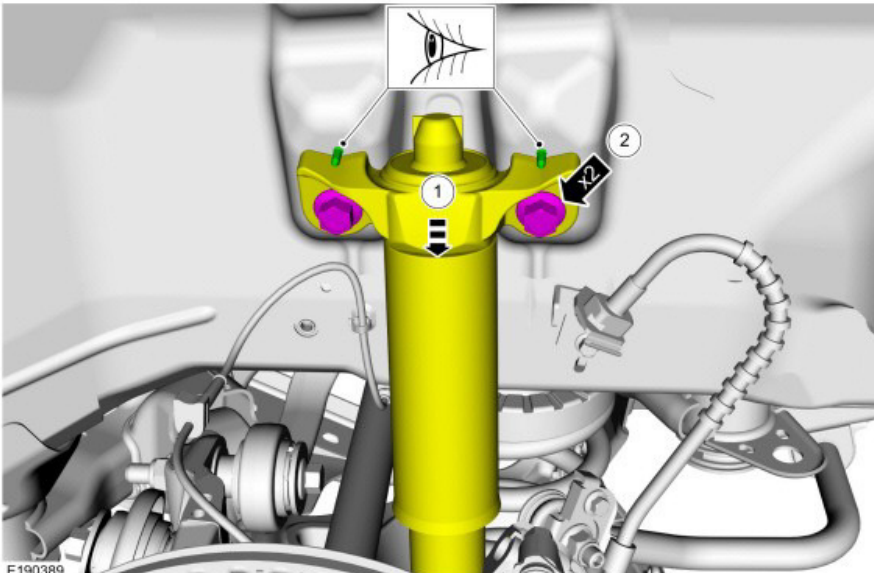



NO PART OF THIS DOCUMENT MAY BE REPRODUCED WITHOUT PRIOR AGREEMENT AND WRITTEN PERMISSION OF FORD PERFORMANCE RACING PARTS.

13. Install the Ford Performance Toe Link

NOTICE: Tighten the suspension bushing fasteners with the suspension loaded or with the weight of the vehicle resting on the wheels and tires, otherwise incorrect clamp load and bushing damage may occur.

13.1 NOTE: Align reference marks made during removal.

Position the toe link.

13.1.1 Install the toe link-to-frame bolt with the new nut (W716343-S440), labeled 1 below. Do not yet install the toe link-to-knuckle bolt. NOTE: Ensure that the cams are aligned to the same position from disassembly, utilizing the paint pen marks.

NOTE: Only lightly tighten the bolt at this stage.

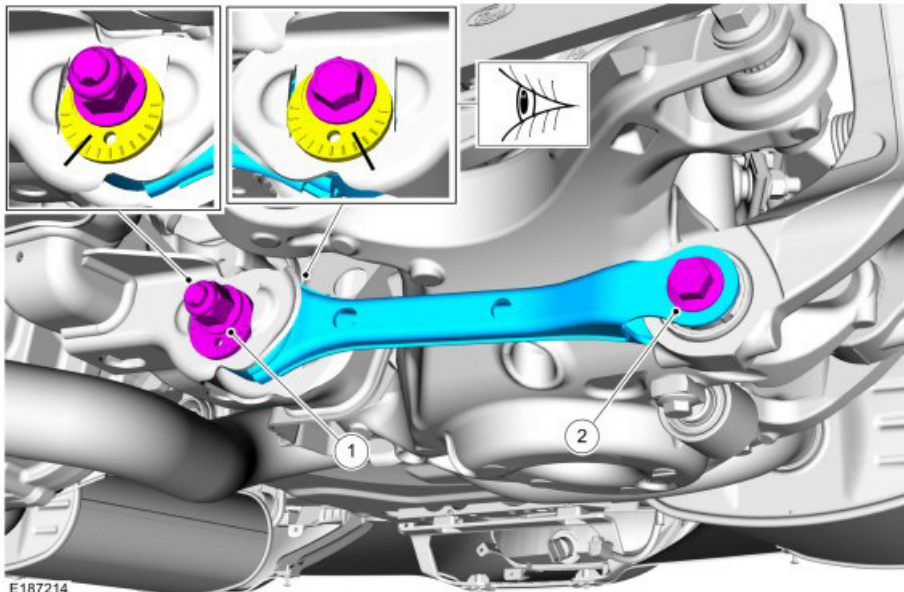



NO PART OF THIS DOCUMENT MAY BE REPRODUCED WITHOUT PRIOR AGREEMENT AND WRITTEN PERMISSION OF FORD PERFORMANCE RACING PARTS.

14. Attach the rear wheel knuckle with Ford Performance Toe Link Bearing installed.

NOTICE: Tighten the suspension bushing fasteners with the suspension loaded or with the weight of the vehicle resting on the wheels and tires, otherwise incorrect clamp load and bushing damage may occur.

14.1 14.1.1 Position the wheel knuckle and install the wheel knuckle-to-lower arm bolt (labeled 1 below). Apply Loc-Tite to bolt and tighten to torque.

Torque: 203 lb.ft (275 Nm)

14.1.2 Install the wheel knuckle-to-toe link bolt and nut. Apply Loc-Tite to bolt and tighten to torque.

Torque: 129 lb.ft (175 Nm)

NOTE: Image shows hub removed.

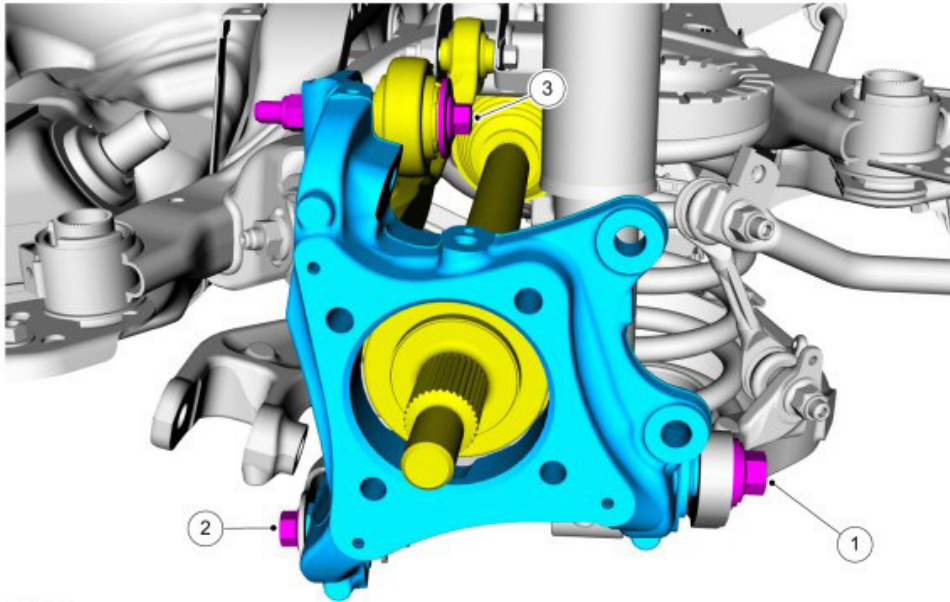

E187249



NO PART OF THIS DOCUMENT MAY BE REPRODUCED WITHOUT PRIOR AGREEMENT AND WRITTEN PERMISSION OF FORD PERFORMANCE RACING PARTS.

14.2

14.2.1 Position the parking brake cable bracket and install the parking brake cable bracket bolt.

Torque: 21 lb.ft (28 Nm)

14.2.2 Position the wheel speed sensor and install the wheel speed sensor bolt.

Torque: 80 lb.in (9 Nm)

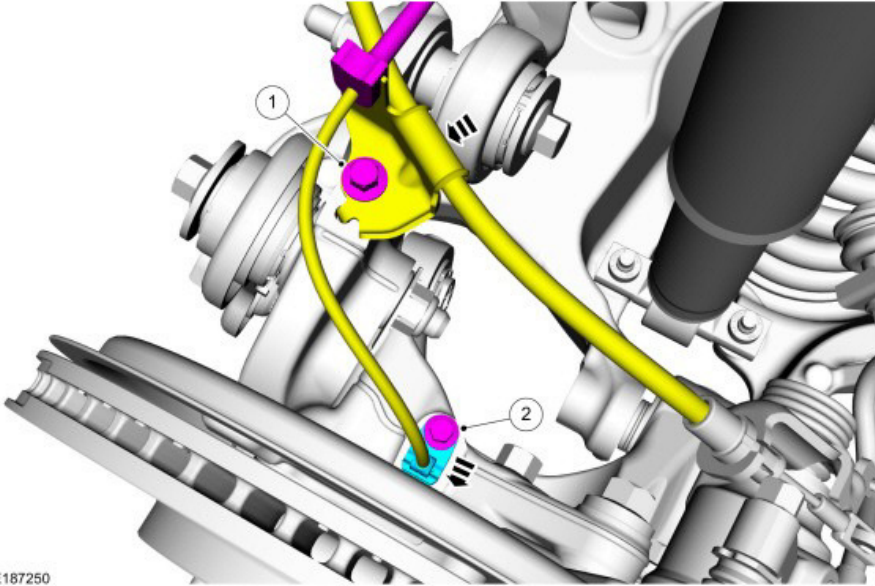

E187250

14.3 Install the lower bolt for the integral link to the lower control arm (labeled 2 below). Apply Loc-Tite to bolt and tighten to torque. The upper bolt should have been left attached.

Torque: 129 lb.ft (175 Nm)

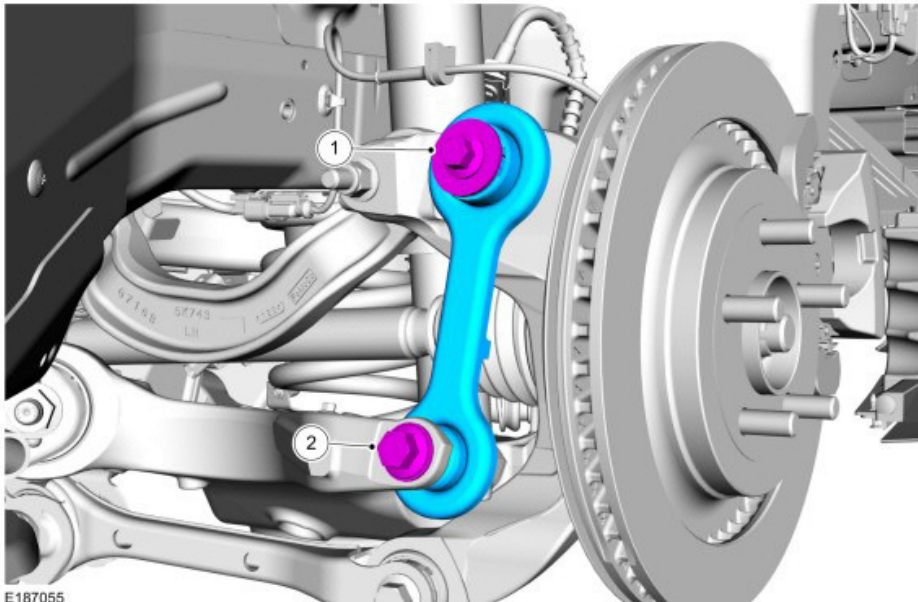

E187055



NO PART OF THIS DOCUMENT MAY BE REPRODUCED WITHOUT PRIOR AGREEMENT AND WRITTEN PERMISSION OF FORD PERFORMANCE RACING PARTS.

15. Install the brake rotor and caliper.

15.1 Assemble the brake rotor to the hub.

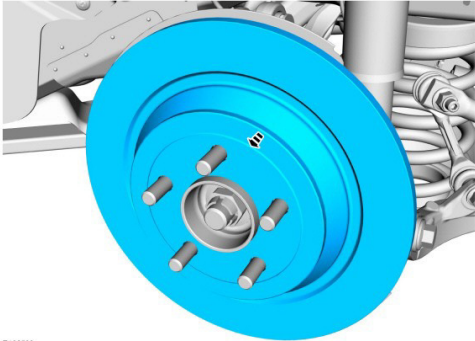

E186590

15.2 Position the brake caliper and install the 2 caliper bracket bolts. Apply Loc-Tite to bolts and tighten to torque. Torque: 129 lb.ft (175 Nm)

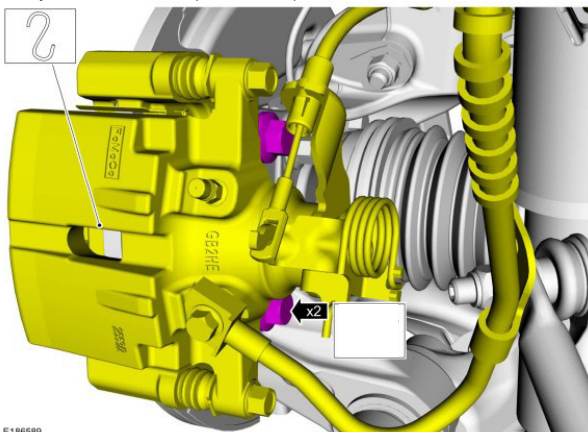

E186589

16. Remove the rear stabilizer bar.

16.1 Ensure that the upper stabilizer bar nut has been removed and discarded, from step 7.2.

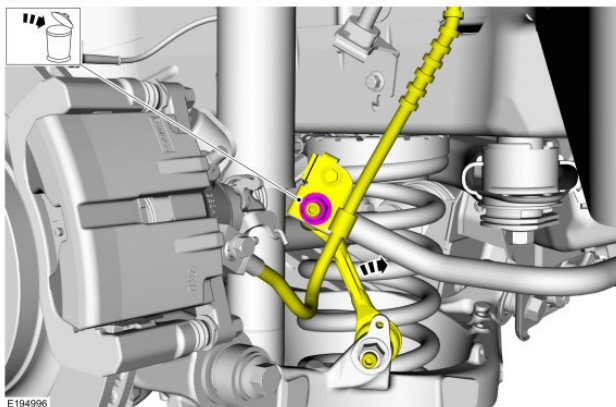

E194996



NO PART OF THIS DOCUMENT MAY BE REPRODUCED WITHOUT PRIOR AGREEMENT AND WRITTEN PERMISSION OF FORD PERFORMANCE RACING PARTS.

16.2 Remove the 4 stabilizer bar bracket bolts and remove the stabilizer bar.

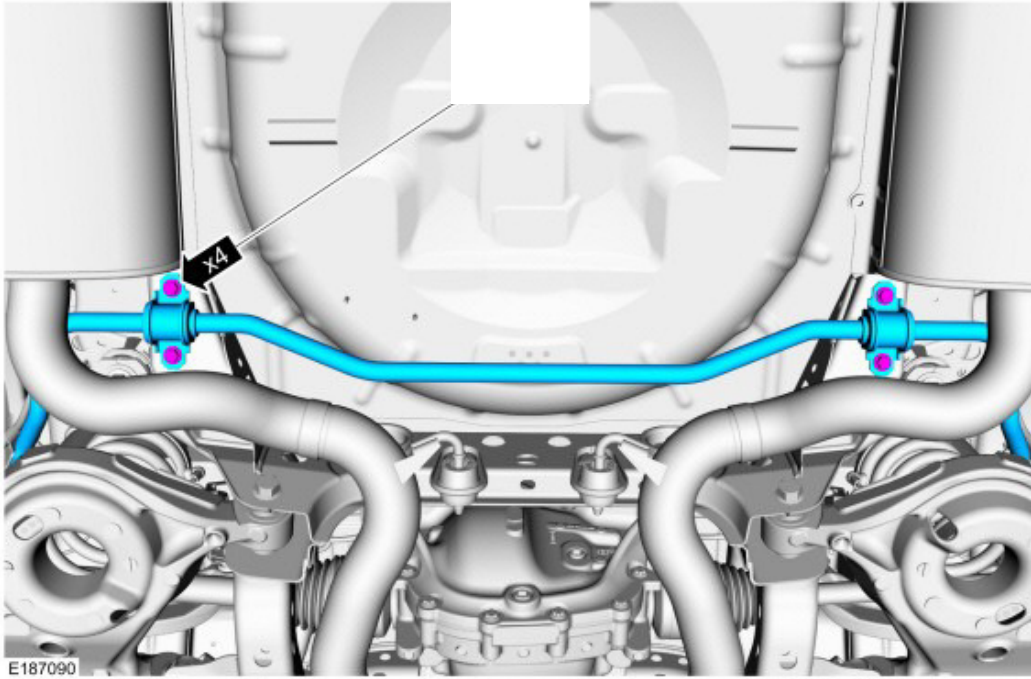

17. Install the new Ford Performance rear stabilizer bar.

17.1 Position the stabilizer bar and install the 4 stabilizer bar bracket bolts. Apply Loc-Tite to bolts and tighten to torque.

Torque: 52 lb.ft (70 Nm)

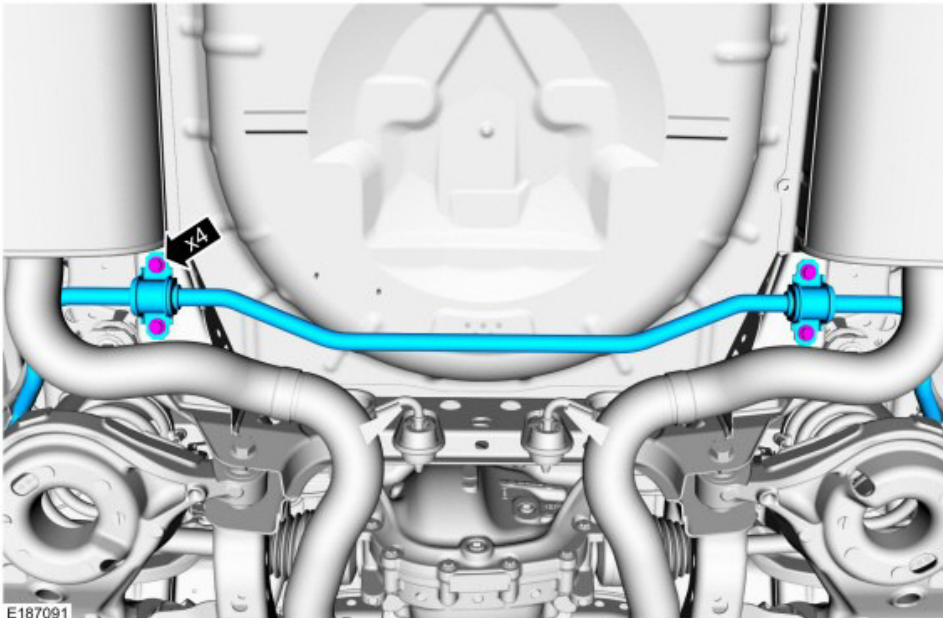



NO PART OF THIS DOCUMENT MAY BE REPRODUCED WITHOUT PRIOR AGREEMENT AND WRITTEN PERMISSION OF FORD PERFORMANCE RACING PARTS.

17.2 18.2.1 On both sides. Position the stabilizer bar link.

NOTE: Use the hex-holding feature to prevent the ball stud from turning while installing the stabilizer bar link nut.

17.2.2 On both sides. Install the new stabilizer bar link upper nut (W705606-S440).

Torque: 85 lb.ft (115 Nm)

NOTE: Install stabilizer bar link in softer (vehicle forward) position first, and adjust if necessary.

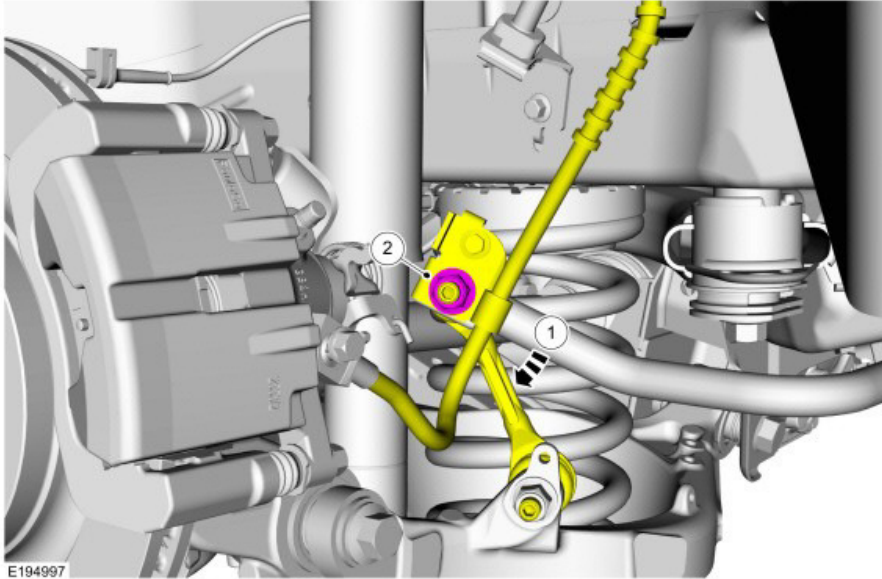

E194997

18. Tighten the suspension to frame bolts at ride height

NOTICE: Tighten the suspension bushing fasteners with the suspension loaded or with the weight of the vehicle resting on the wheels and tires, otherwise incorrect clamp load and bushing damage may occur.

18.1 With the vehicle lowered on the ground, tighten the rearward lower control arm-to-frame bolt. (labeled 1 below)

Torque: 184 lb.ft (250 Nm)

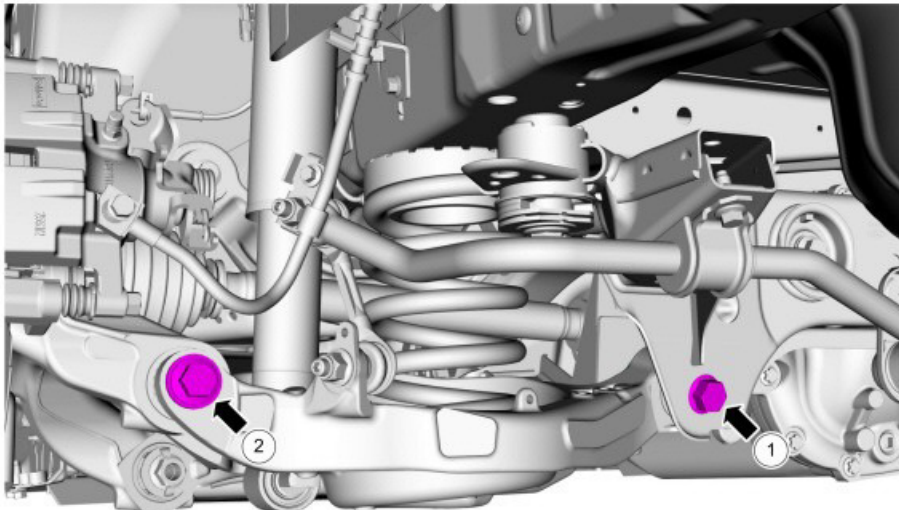

E194914



NO PART OF THIS DOCUMENT MAY BE REPRODUCED WITHOUT PRIOR AGREEMENT AND WRITTEN PERMISSION OF FORD PERFORMANCE RACING PARTS.

18.2 Tighten the forward lower control arm-to-frame bolt.
Torque: 166 lb.ft (225 Nm)

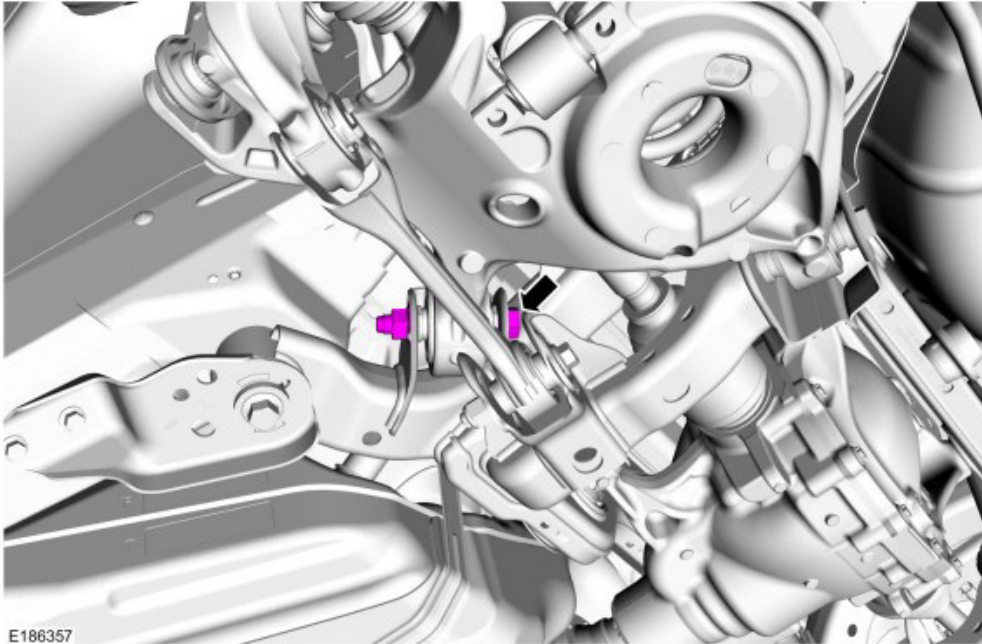

18.3 Tighten the toe link to frame bolt, ensuring the cam is in the correct position.
Torque: 129 lb.ft (175 Nm)

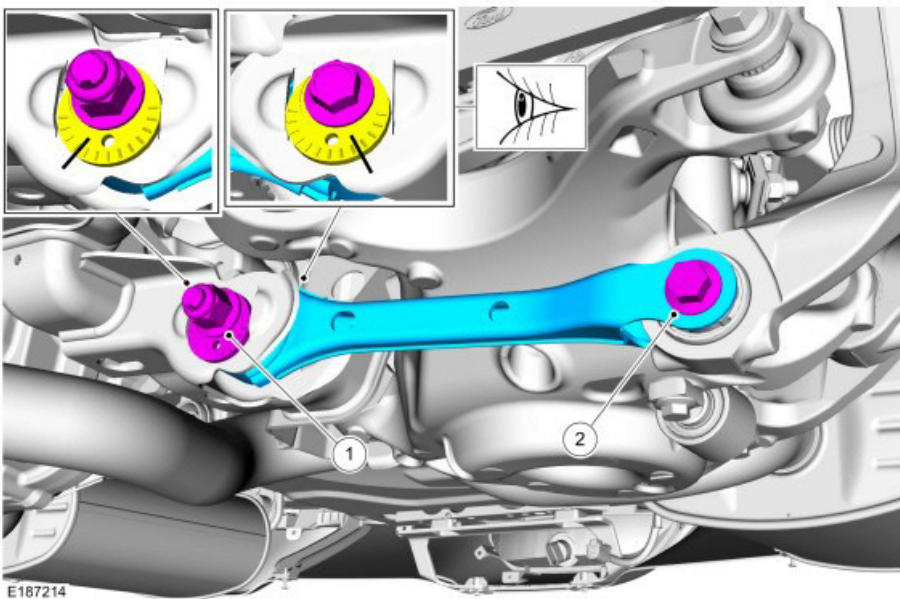



NO PART OF THIS DOCUMENT MAY BE REPRODUCED WITHOUT PRIOR AGREEMENT AND WRITTEN PERMISSION OF FORD PERFORMANCE RACING PARTS.

19. Install the muffler and tailpipe by reversing the removal procedure.

20. Install the wheels and tires

20.1 Tighten the wheel nuts in a star pattern. Torque: 148 lb.ft (200 Nm)

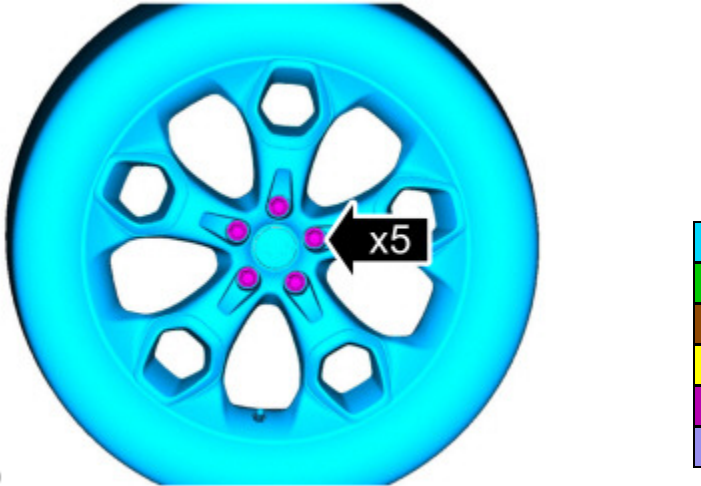

E145710

21. Set desired alignment on front and rear axles.

21.1 Choose either Ford factory Performance Pack alignment specification, or Ford Performance Suggested alignment. 5.0L and 2.3L vehicles have the same specifications.

Factory Spec	Camber	Total Toe
Front	-1.03	0.00
Rear	-1.50	0.23

Ford Performance Spec	Camber	Total Toe
Front	-1.55	0.00
Rear	-1.98	0.23

NOTE: Ford Performance alignment specification may result in accelerated tire wear, with the benefit of improved vehicle response and handling.