



M-15200K-CXR  
2021 Bronco Sport Off-Road  
Roof-Mounted LED Light Bar

NO PART OF THIS DOCUMENT MAY BE REPRODUCED WITHOUT PRIOR AGREEMENT AND WRITTEN PERMISSION OF FORD PERFORMANCE PARTS

**PRIOR TO INSTALLATION READ THESE INSTRUCTION COMPLETELY**  
For questions, Call the FORD PERFORMANCE Techline 1-800-367-3788

Please visit <https://www.performanceparts.ford.com> for warranty information



Kit Contents	Quantity
SR-series 40" straight light bar	1
SR 10" Lens Covers	4
Rocker switch, cherry, 2-position	1
Switch wiring adapter kit	1
Mounting fasteners/tools kit	1
Roof rack bracket, RH	1
Roof rack bracket, LH	1
Rigid hardware kit	1
Air Damper	1

Ford Factory Shop Manual purchase options [www.motorcraftservice.com](http://www.motorcraftservice.com)



FORD PERFORMANCE

# M-15200K-CXR 2021 Bronco Sport Off-Road Roof-Mounted LED Light Bar

NO PART OF THIS DOCUMENT MAY BE REPRODUCED WITHOUT PRIOR AGREEMENT AND WRITTEN PERMISSION OF FORD PERFORMANCE PARTS

## INSTALLATION PROCEDURE

**NOTE:** Use the General Equipment: Interior Trim Remover.

1. Install the air damper into the Rigid light bar. See Figure 1.



**FIGURE 1**

2. Position aside the left hand (LH) side A-pillar trim panel. See Figure 2.

1. Release the clips.
2. Lifting upward and backward on the A-pillar trim panel, release the lower tabs from the instrument panel.

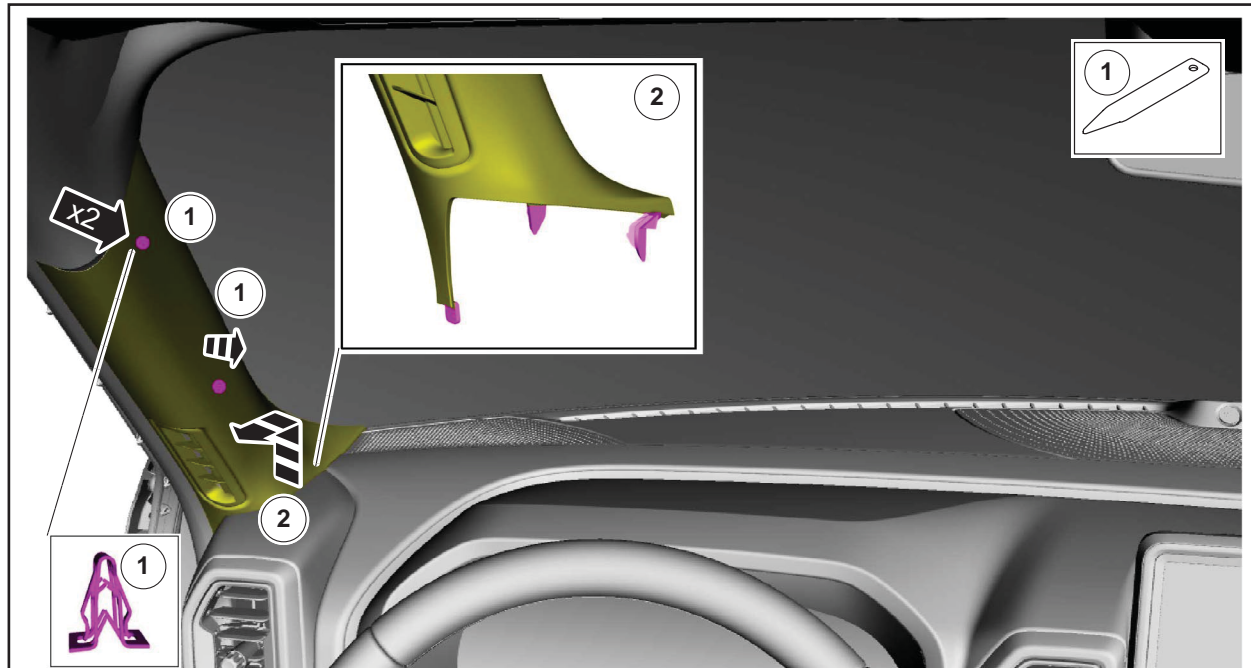

**FIGURE 2**

Ford Factory Shop Manual purchase options [www.motorcraftservice.com](http://www.motorcraftservice.com)

NO PART OF THIS DOCUMENT MAY BE REPRODUCED WITHOUT PRIOR AGREEMENT AND WRITTEN PERMISSION OF  
FORD PERFORMANCE PARTS

3. Remove the LH A-pillar trim panel. See Figure 3.

1. Remove the A-pillar trim panel tether cord hold down nut.
  - Torque: 55 lb.in (6.2 Nm)
2. Remove the A-pillar trim panel tether cord from the post.
3. Remove the A-pillar trim panel.

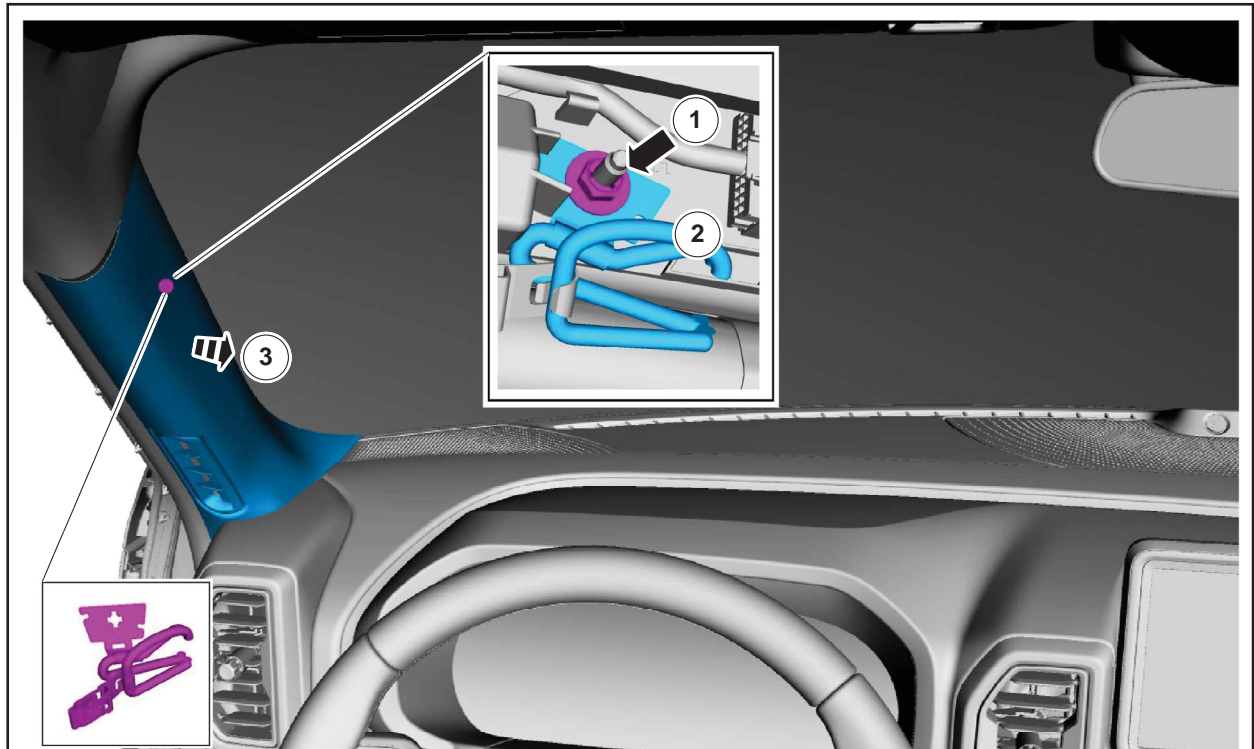

FIGURE 3



**FORD PERFORMANCE**

M-15200K-CXR  
2021 Bronco Sport Off-Road  
Roof-Mounted LED Light Bar

NO PART OF THIS DOCUMENT MAY BE REPRODUCED WITHOUT PRIOR AGREEMENT AND WRITTEN PERMISSION OF  
FORD PERFORMANCE PARTS

4. Position the front LH seat in the full forward position. See Figure 4.



**FIGURE 4**



NO PART OF THIS DOCUMENT MAY BE REPRODUCED WITHOUT PRIOR AGREEMENT AND WRITTEN PERMISSION OF FORD PERFORMANCE PARTS

**NOTE:** Be sure not to over articulate the lower B-pillar which may cause stress marks, creases, and or damage.

**NOTE:** Driver seat and seatbelt removed for clarity.

5. Position aside the top portion of the LH lower B-pillar aside. See Figure 5.

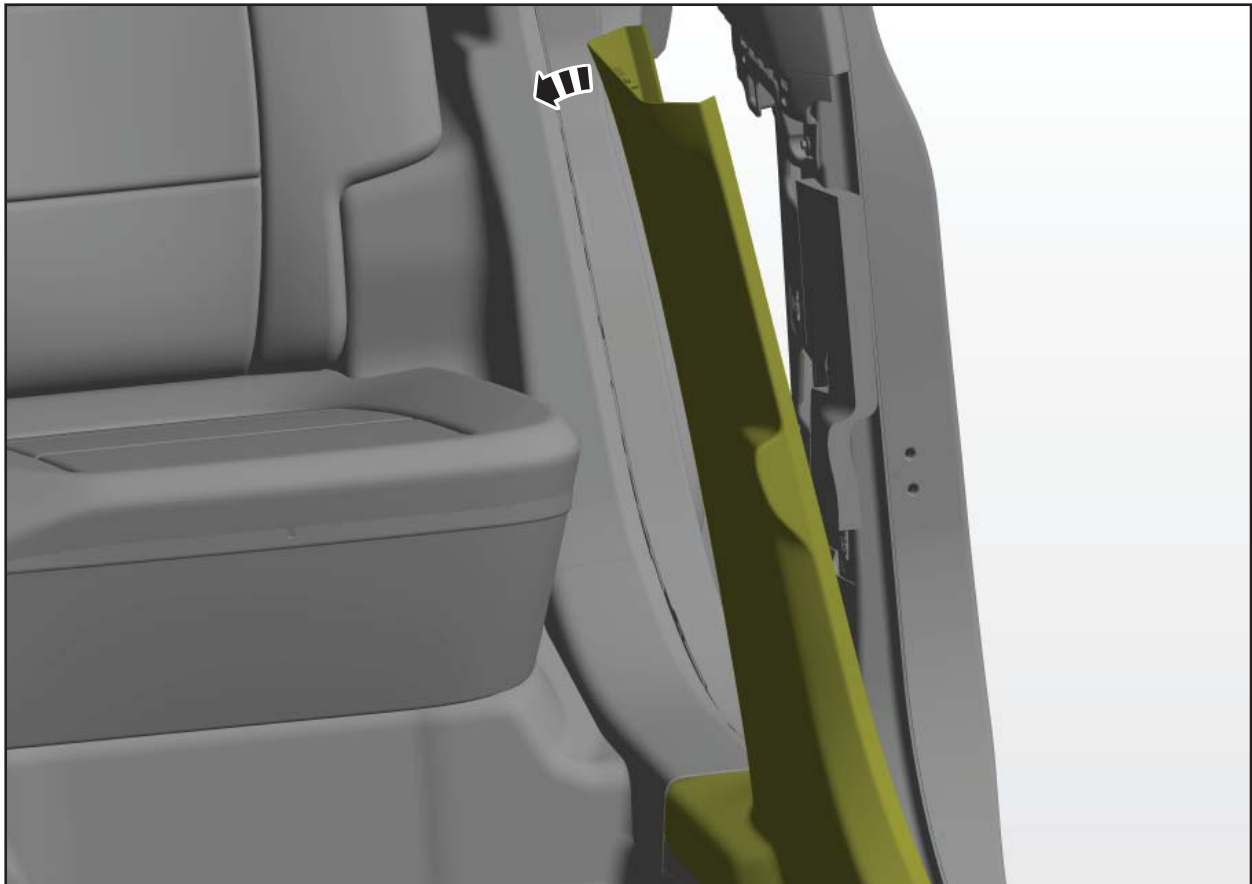

**FIGURE 5**



FORD PERFORMANCE

# M-15200K-CXR 2021 Bronco Sport Off-Road Roof-Mounted LED Light Bar

NO PART OF THIS DOCUMENT MAY BE REPRODUCED WITHOUT PRIOR AGREEMENT AND WRITTEN PERMISSION OF FORD PERFORMANCE PARTS

**NOTE:** Seats removed for clarity.

6. Remove the upper LH B-pillar trim panel bolt. See Figure 6.
  - *Torque:* 80 lb.in (9 Nm)

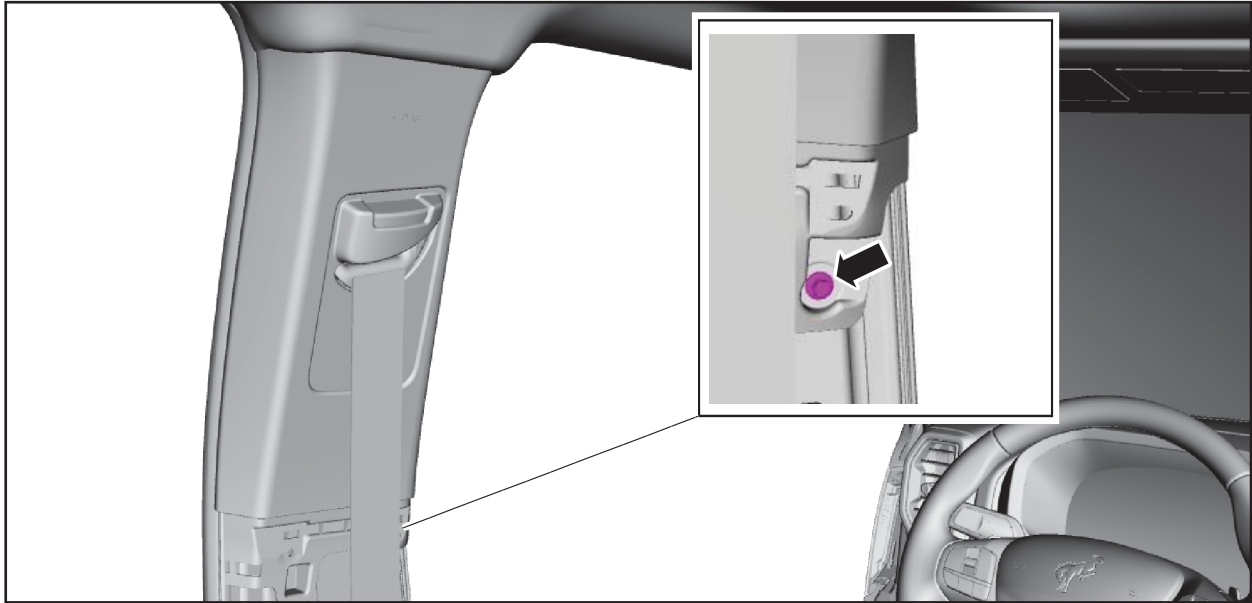
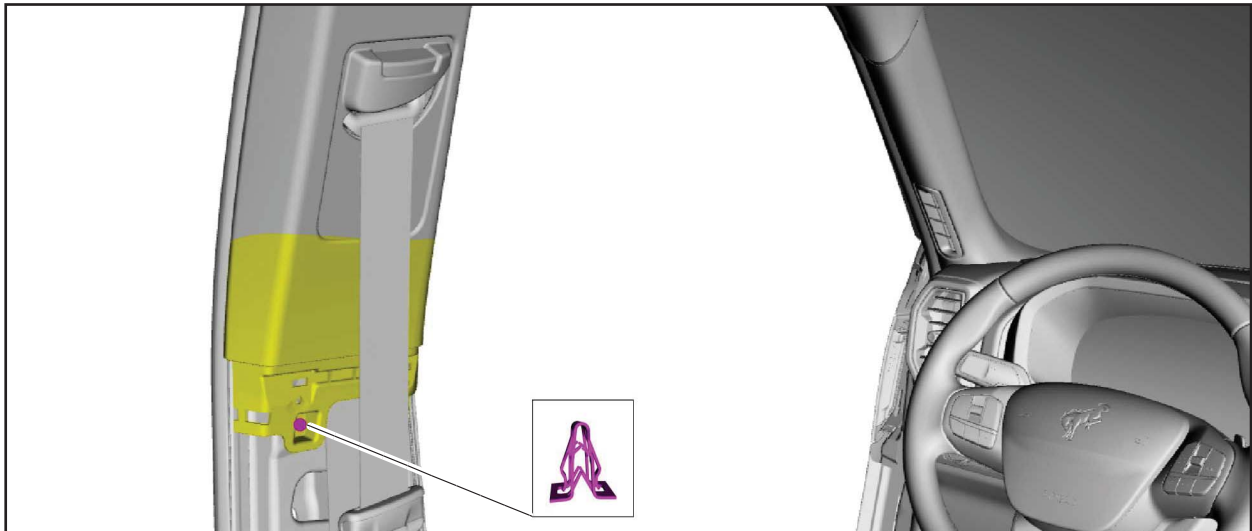

**FIGURE 6**

**NOTE:** Use the General Equipment: Interior Trim Remover.

**NOTE:** Seats removed for clarity.

7. Release the upper B-pillar trim panel lower clip. See Figure 7.



**FIGURE 7**

Ford Factory Shop Manual purchase options [www.motorcraftservice.com](http://www.motorcraftservice.com)



FORD PERFORMANCE

M-15200K-CXR  
2021 Bronco Sport Off-Road  
Roof-Mounted LED Light Bar

NO PART OF THIS DOCUMENT MAY BE REPRODUCED WITHOUT PRIOR AGREEMENT AND WRITTEN PERMISSION OF FORD PERFORMANCE PARTS

**NOTICE:** The upper B-pillar trim panel must be positioned downward to allow the upper clips to release correctly. Failure to follow this direction may cause damage to the upper B-pillar trim panel.

**NOTE:** Seats removed for clarity.

8. Slide the upper B-pillar trim panel down, aligning the clips to the slots in the sheet metal. See Figure 8.

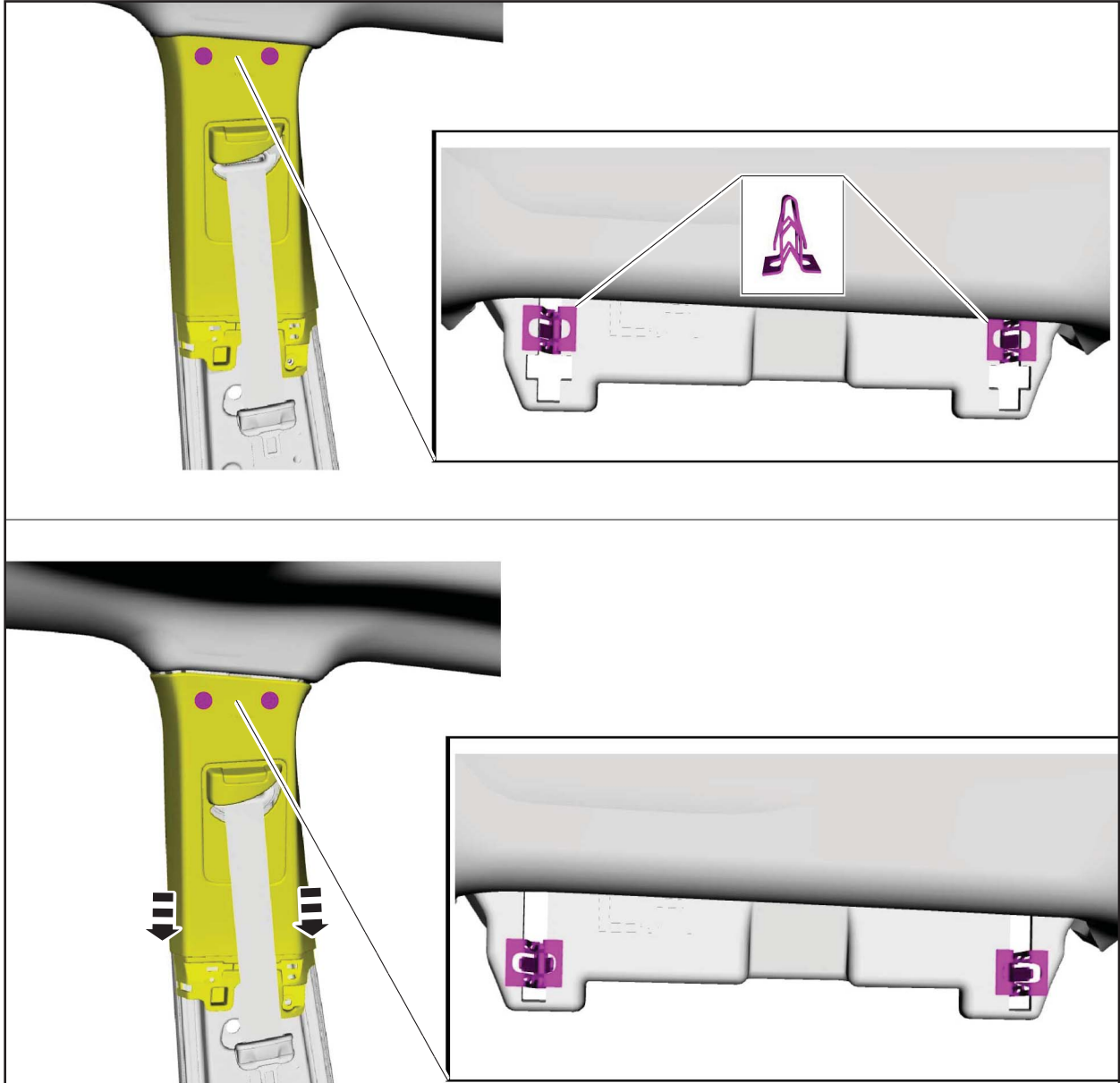

FIGURE 8

Ford Factory Shop Manual purchase options [www.motorcraftservice.com](http://www.motorcraftservice.com)



FORD PERFORMANCE

# M-15200K-CXR 2021 Bronco Sport Off-Road Roof-Mounted LED Light Bar

NO PART OF THIS DOCUMENT MAY BE REPRODUCED WITHOUT PRIOR AGREEMENT AND WRITTEN PERMISSION OF FORD PERFORMANCE PARTS

9. Position the upper B-pillar down the seatbelt and out of the way. See Figure 9.

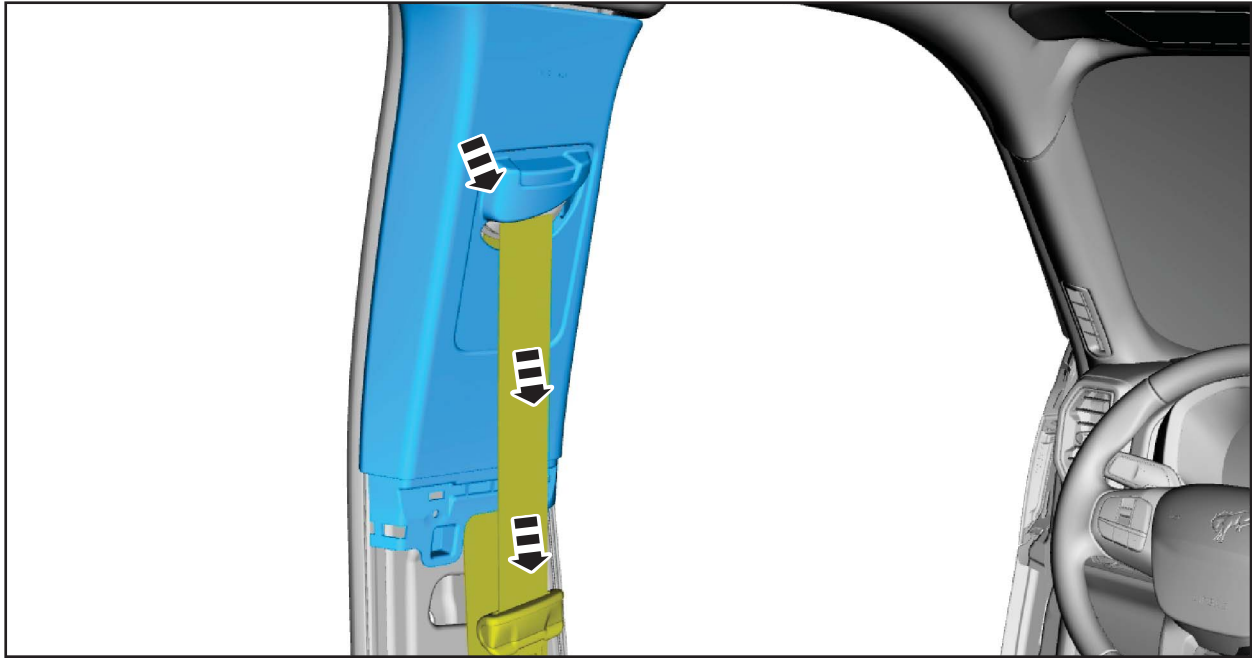

FIGURE 9

**NOTE:** Use the General Equipment: Interior Trim Remover.

10. Remove the LH rear scuff plate trim panel. See Figure 10.

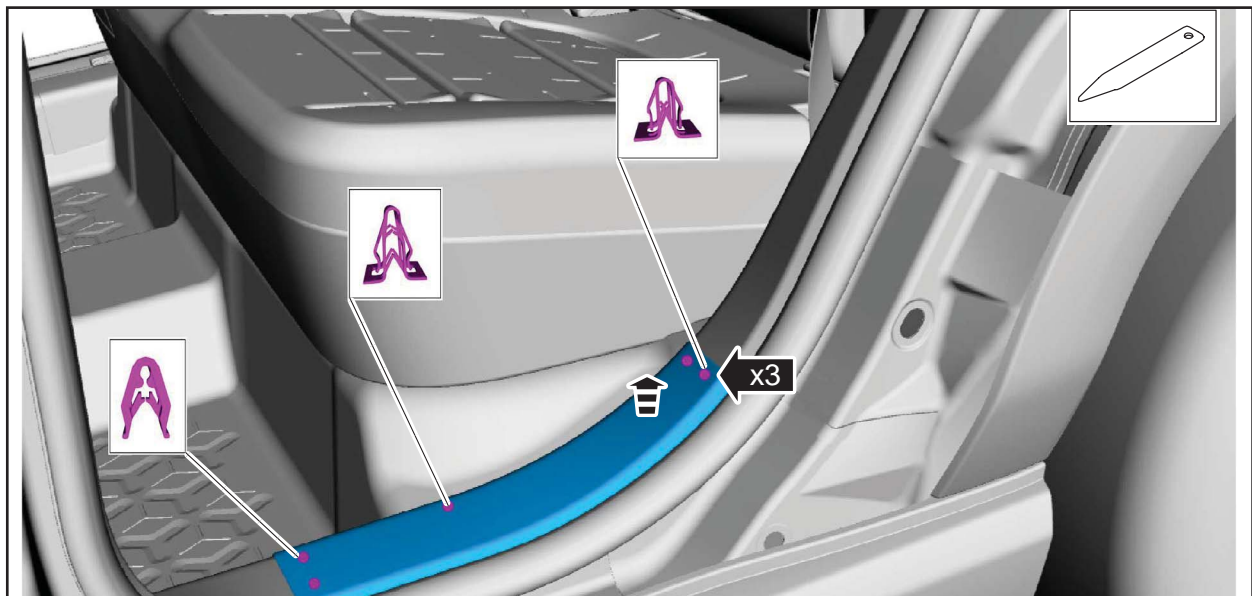

FIGURE 10

Ford Factory Shop Manual purchase options [www.motorcraftservice.com](http://www.motorcraftservice.com)



NO PART OF THIS DOCUMENT MAY BE REPRODUCED WITHOUT PRIOR AGREEMENT AND WRITTEN PERMISSION OF FORD PERFORMANCE PARTS

11. Position the LH portion of the liftgate weatherstrip aside. See Figure 11.

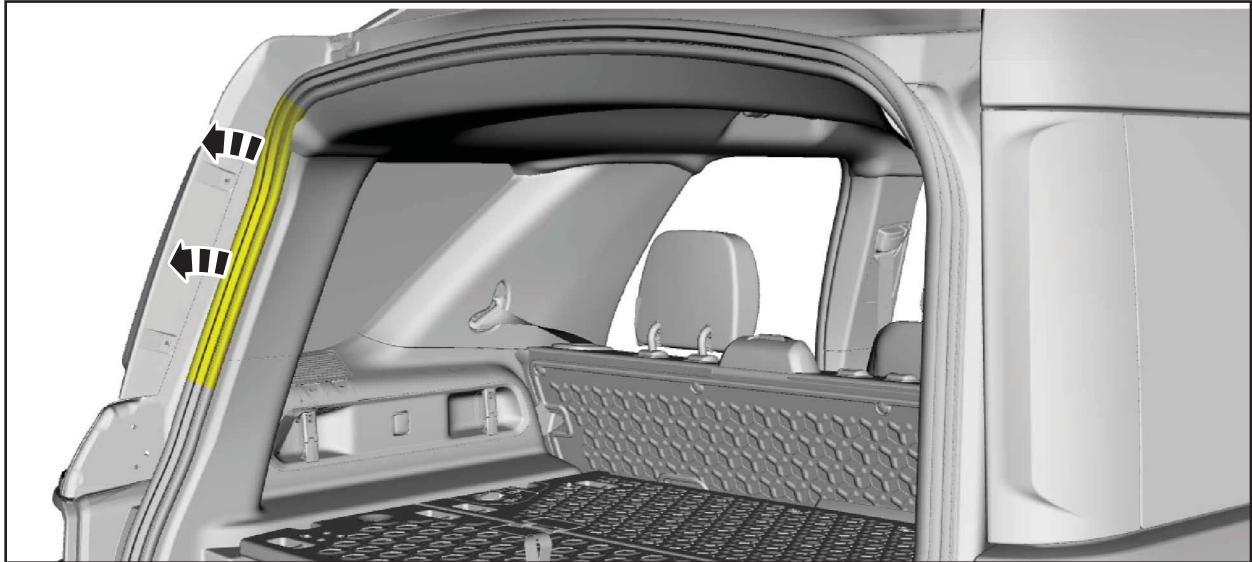

FIGURE 11

**NOTE:** Use the General Equipment: Interior Trim Remover.

12. Release the LH D-pillar trim panel lower clips. See Figure 12.

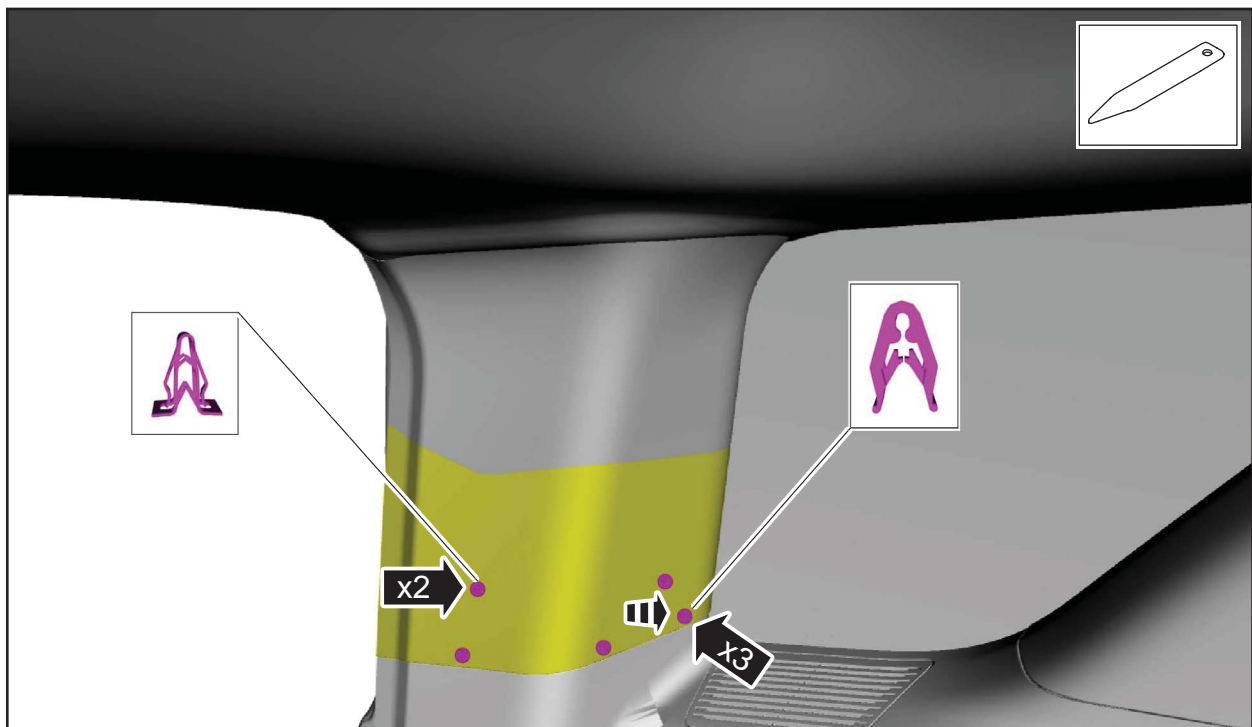

FIGURE 12

Ford Factory Shop Manual purchase options [www.motorcraftservice.com](http://www.motorcraftservice.com)



FORD PERFORMANCE

# M-15200K-CXR 2021 Bronco Sport Off-Road Roof-Mounted LED Light Bar

NO PART OF THIS DOCUMENT MAY BE REPRODUCED WITHOUT PRIOR AGREEMENT AND WRITTEN PERMISSION OF FORD PERFORMANCE PARTS

**NOTICE:** The D-pillar trim panel must be positioned upward to allow the upper clips to release correctly. Failure to follow this direction may cause damage to the D-pillar trim panel.

13. Slide the LH D-pillar trim panel up, aligning the clips to the slots in the sheet metal. See Figure 13.

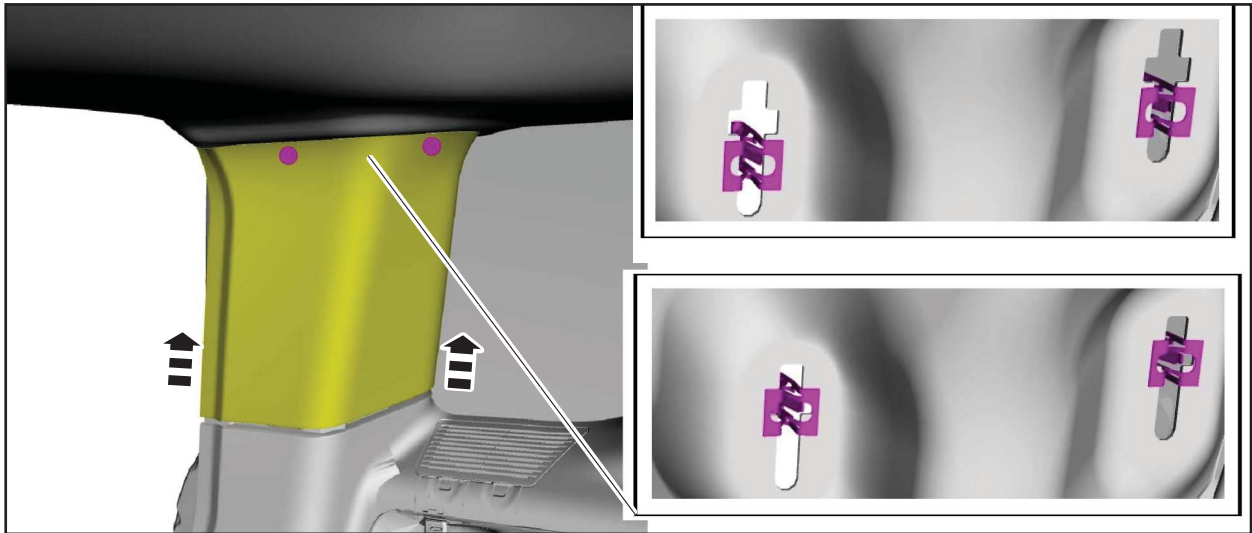

FIGURE 13

14. Remove the LH D-pillar trim panel. See Figure 14.

- Replace the two upper retention clips.

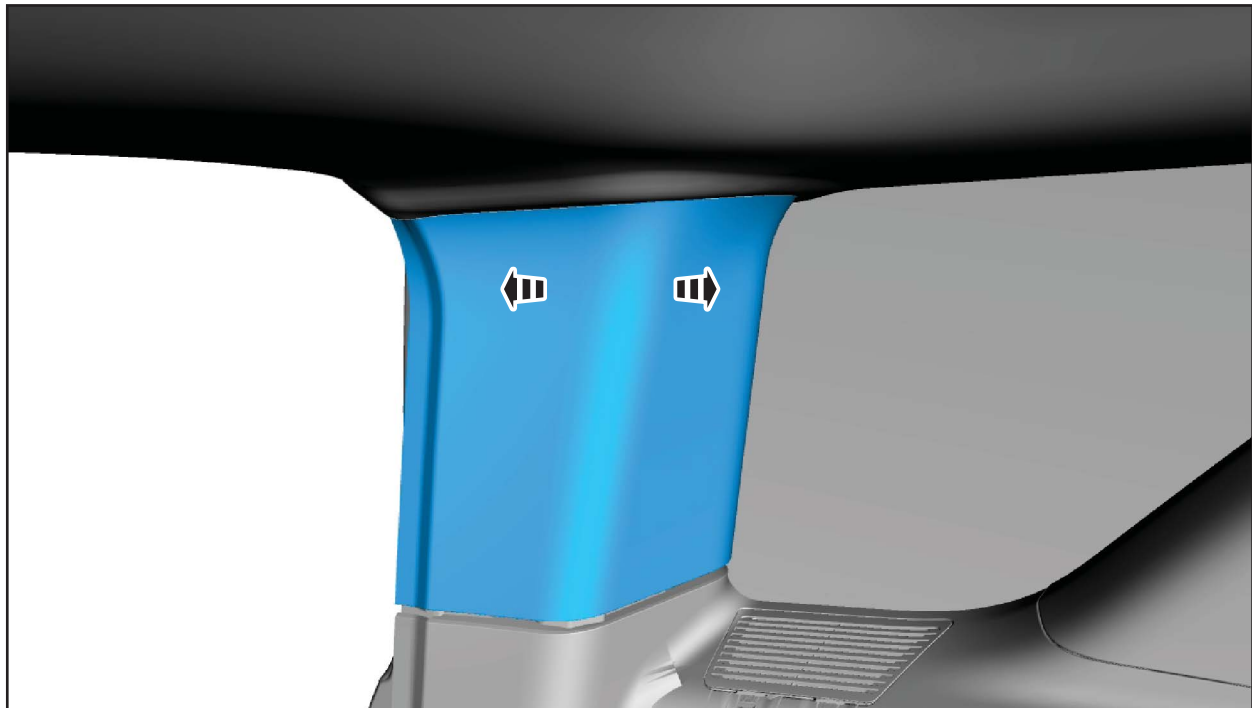

FIGURE 14

Ford Factory Shop Manual purchase options [www.motorcraftservice.com](http://www.motorcraftservice.com)



**FORD PERFORMANCE**

M-15200K-CXR  
2021 Bronco Sport Off-Road  
Roof-Mounted LED Light Bar

NO PART OF THIS DOCUMENT MAY BE REPRODUCED WITHOUT PRIOR AGREEMENT AND WRITTEN PERMISSION OF FORD PERFORMANCE PARTS

15. If equipped, remove the luggage compartment package cover. See Figure 15.

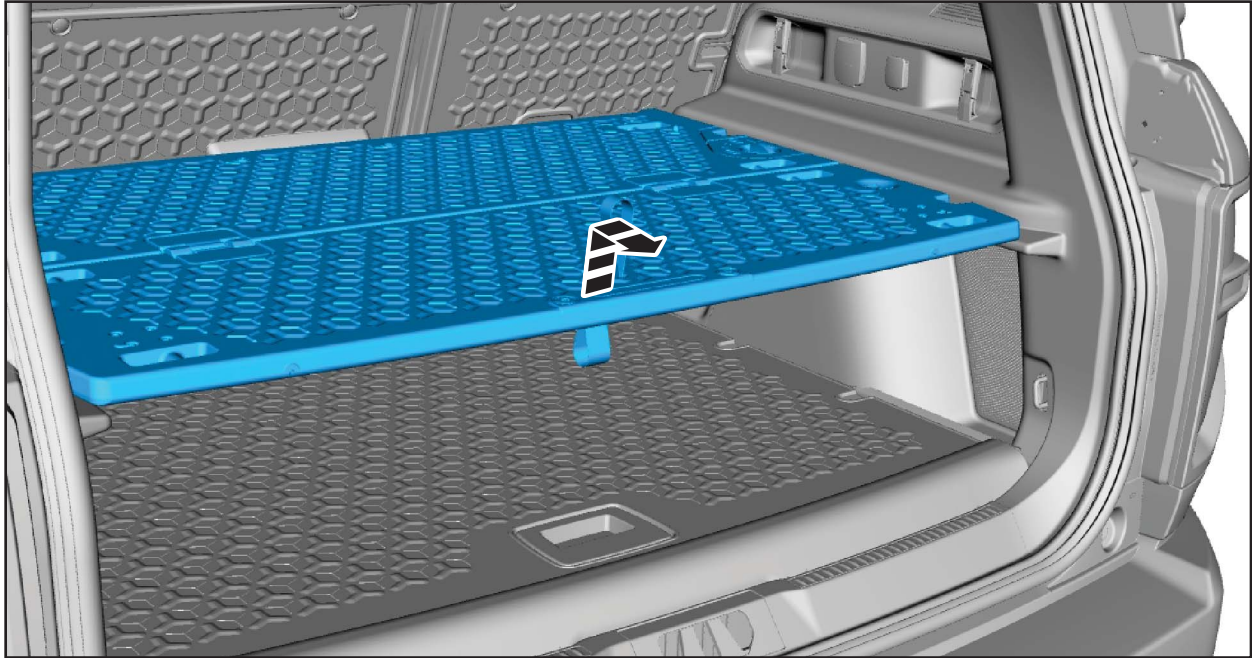

**FIGURE 15**

16. Remove the luggage compartment floor covering. See Figure 16.

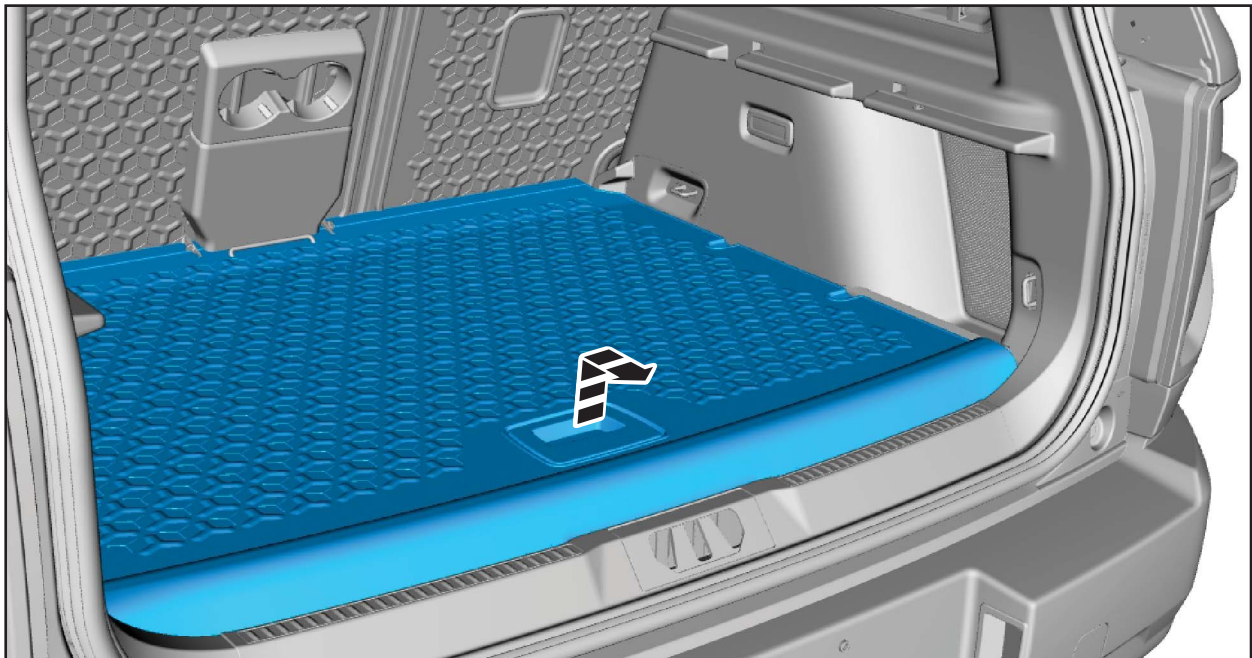

**FIGURE 16**

Ford Factory Shop Manual purchase options [www.motorcraftservice.com](http://www.motorcraftservice.com)





**FORD PERFORMANCE**

M-15200K-CXR  
2021 Bronco Sport Off-Road  
Roof-Mounted LED Light Bar

NO PART OF THIS DOCUMENT MAY BE REPRODUCED WITHOUT PRIOR AGREEMENT AND WRITTEN PERMISSION OF FORD PERFORMANCE PARTS

17. Remove the loadspace scuff plate trim panel bolts. See Figure 17.

- Torque: 80 lb.in (9 Nm)

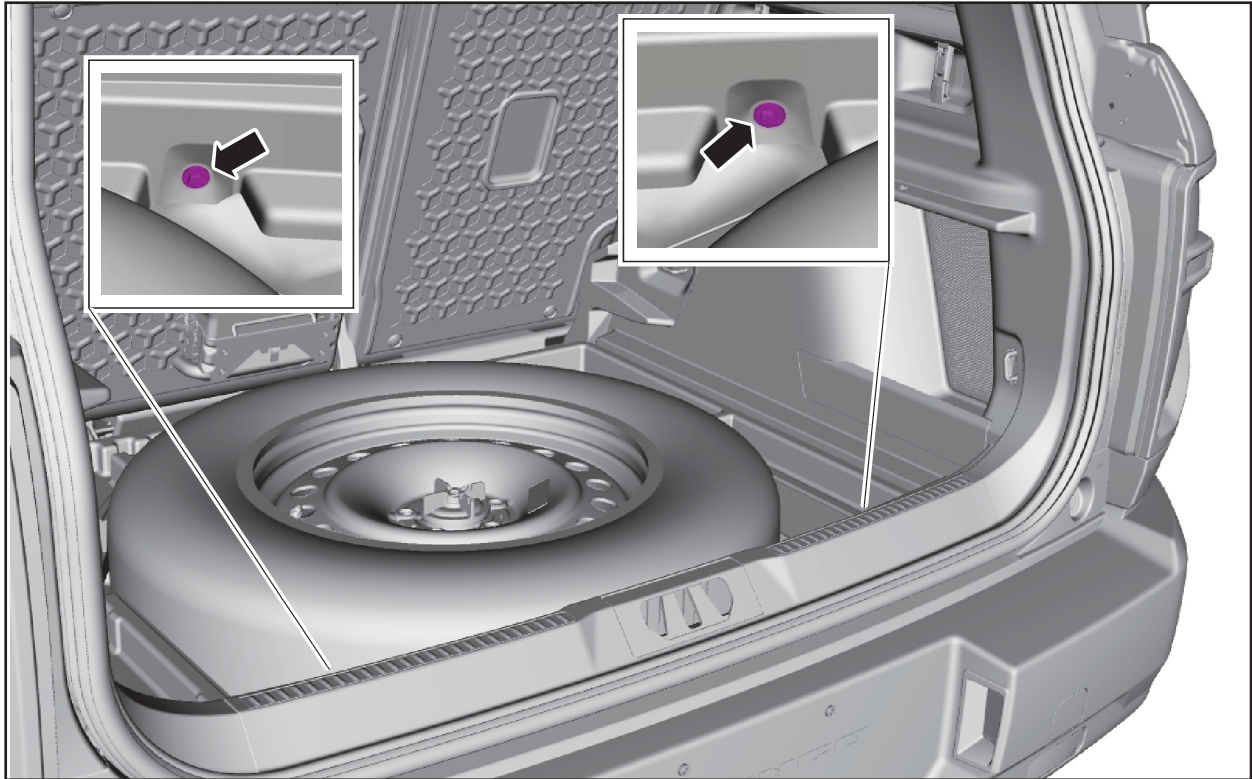

**FIGURE 17**

18. Position the liftgate weatherstrip aside. See Figure 18.

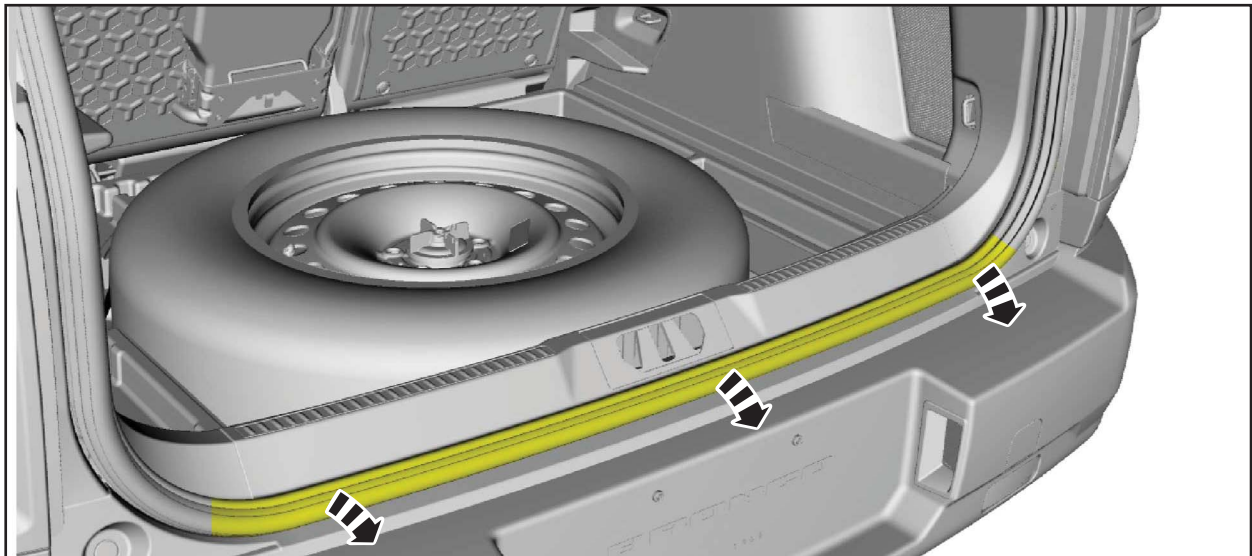

**FIGURE 18**

Ford Factory Shop Manual purchase options [www.motorcraftservice.com](http://www.motorcraftservice.com)





FORD PERFORMANCE

M-15200K-CXR  
2021 Bronco Sport Off-Road  
Roof-Mounted LED Light Bar

NO PART OF THIS DOCUMENT MAY BE REPRODUCED WITHOUT PRIOR AGREEMENT AND WRITTEN PERMISSION OF FORD PERFORMANCE PARTS

**NOTE:** Use the General Equipment: Interior Trim Remover.

19. Release the clips and remove the loadspace scuff plate trim panel. See Figure 19.

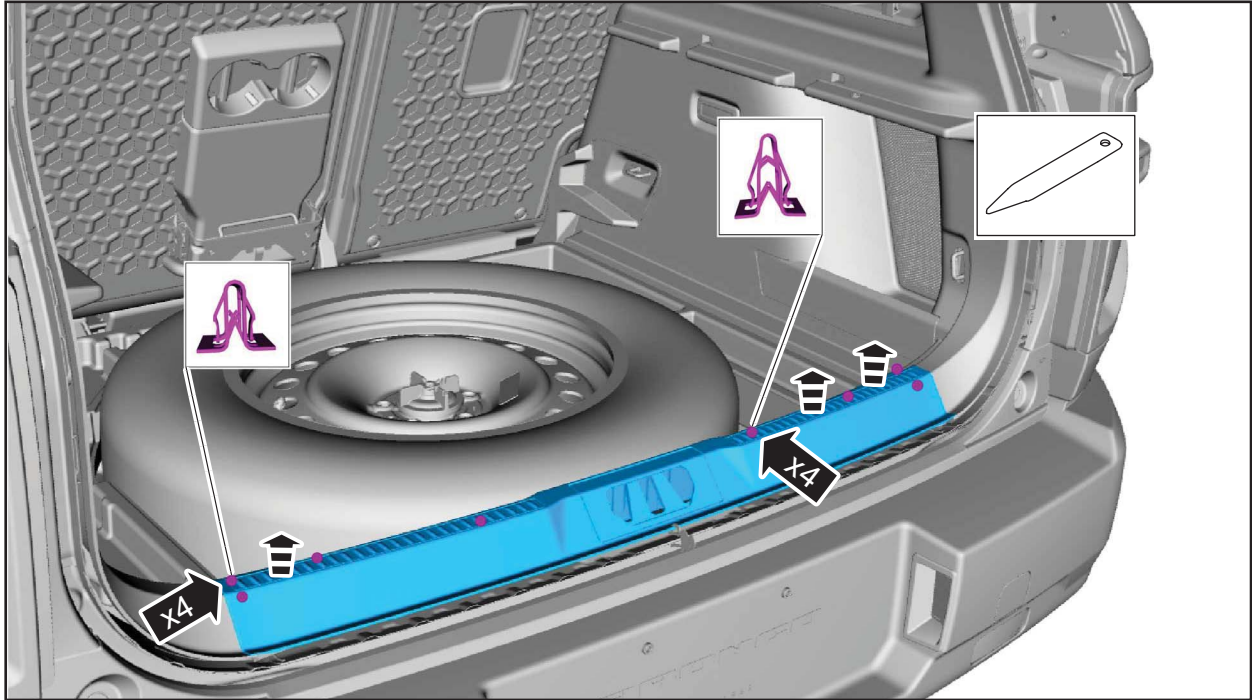

**FIGURE 19**

20. Position the LH liftgate weatherstrip aside. See Figure 20.

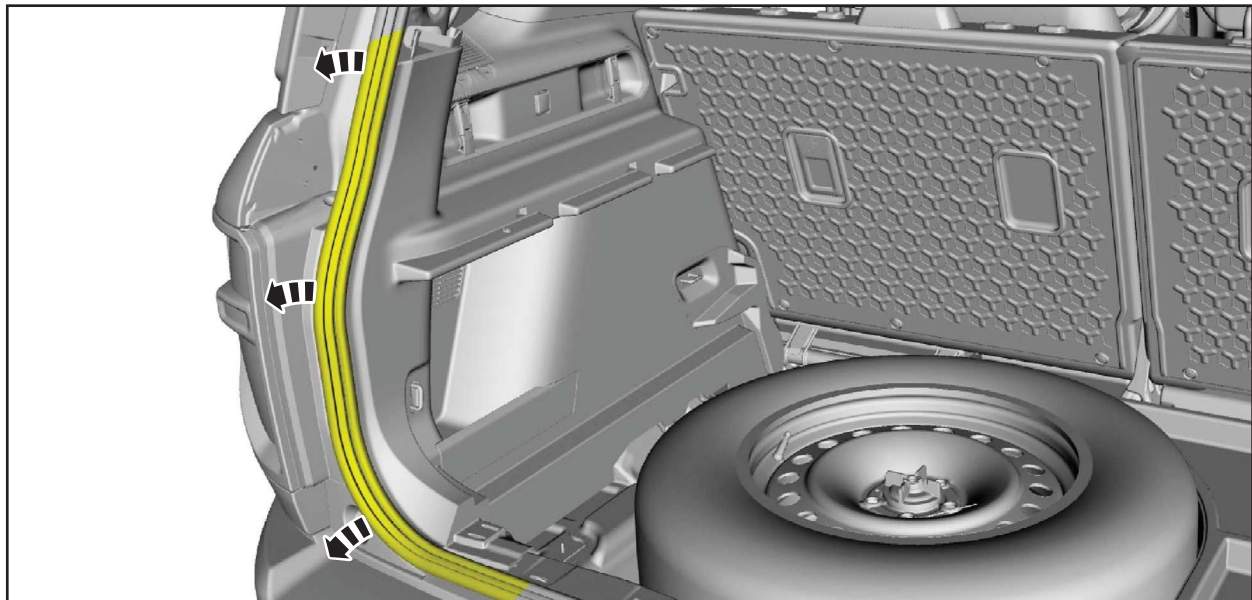

**FIGURE 20**

Ford Factory Shop Manual purchase options [www.motorcraftservice.com](http://www.motorcraftservice.com)



**FORD PERFORMANCE**

M-15200K-CXR  
2021 Bronco Sport Off-Road  
Roof-Mounted LED Light Bar

NO PART OF THIS DOCUMENT MAY BE REPRODUCED WITHOUT PRIOR AGREEMENT AND WRITTEN PERMISSION OF FORD PERFORMANCE PARTS

21. Remove the LH floor storage bin. See Figure 21.

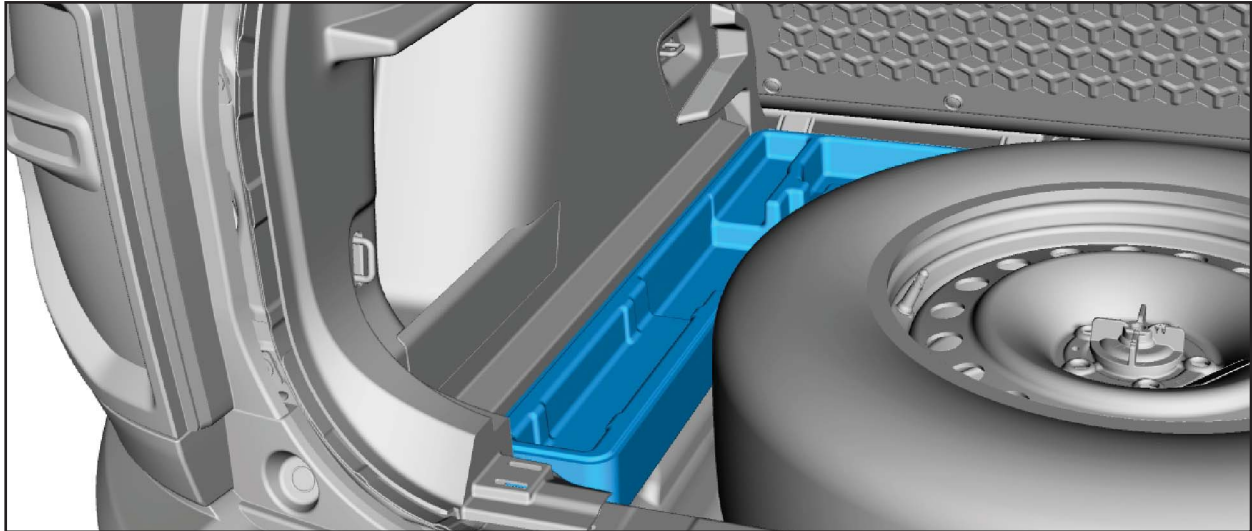

**FIGURE 21**

22. Position the rear seat backrest in the fold flat position. See Figure 22.



**FIGURE 22**

Ford Factory Shop Manual purchase options [www.motorcraftservice.com](http://www.motorcraftservice.com)



FORD PERFORMANCE

# M-15200K-CXR 2021 Bronco Sport Off-Road Roof-Mounted LED Light Bar

NO PART OF THIS DOCUMENT MAY BE REPRODUCED WITHOUT PRIOR AGREEMENT AND WRITTEN PERMISSION OF FORD PERFORMANCE PARTS

**NOTE:** Use the General Equipment: Interior Trim Remover.

23. Remove the LH loadspace trim panel. See Figure 23.

1. Release the loadspace trim panel clips.
2. Position the rear seatbelt retractor and pretensioner through the opening in the loadspace trim panel.
3. Disconnect the power outlet electrical connector.

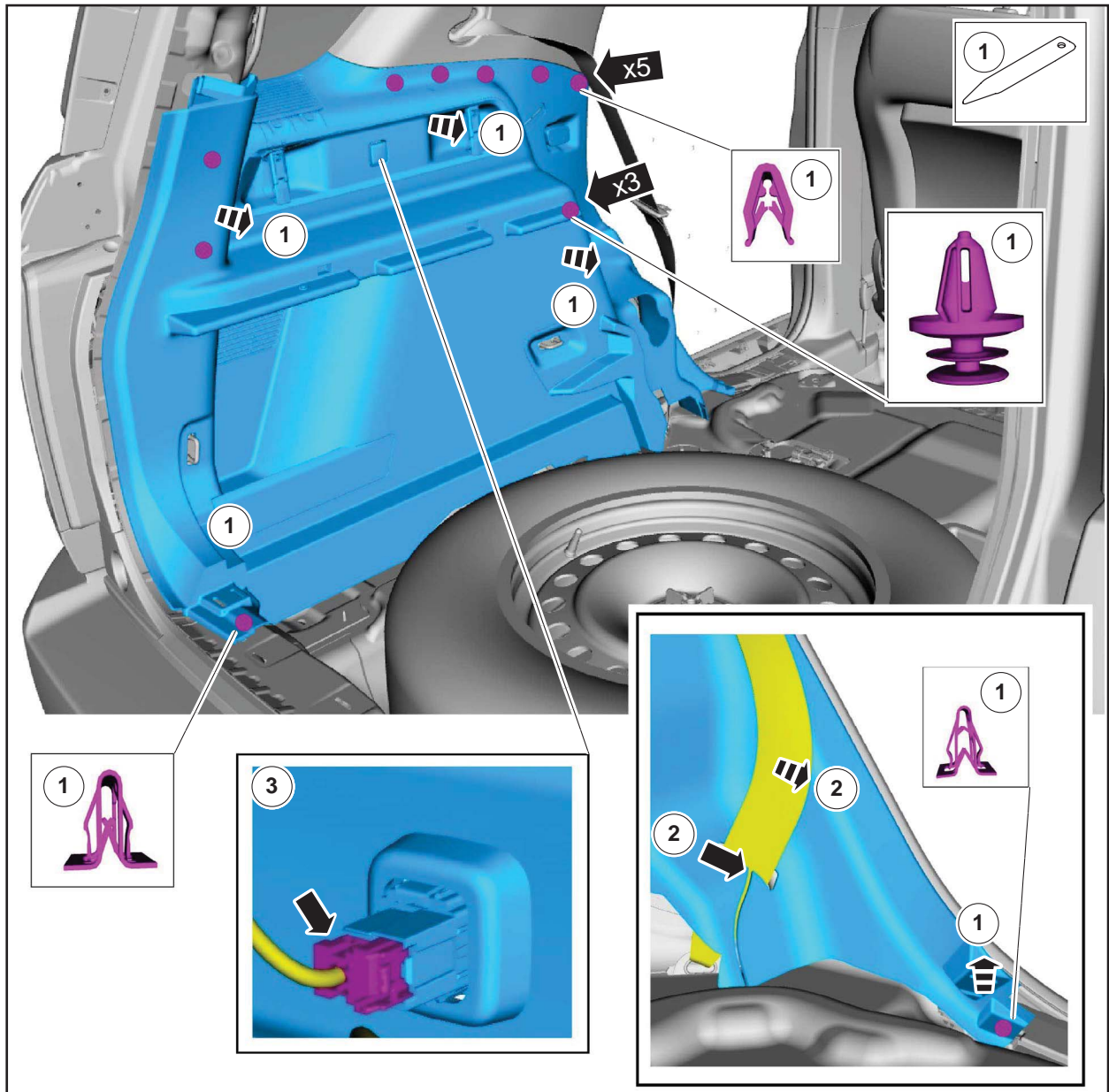

FIGURE 23

Ford Factory Shop Manual purchase options [www.motorcraftservice.com](http://www.motorcraftservice.com)





**FORD PERFORMANCE**

M-15200K-CXR  
2021 Bronco Sport Off-Road  
Roof-Mounted LED Light Bar

NO PART OF THIS DOCUMENT MAY BE REPRODUCED WITHOUT PRIOR AGREEMENT AND WRITTEN PERMISSION OF  
FORD PERFORMANCE PARTS

24. Position the rear seat backrest upward. See Figure 24.

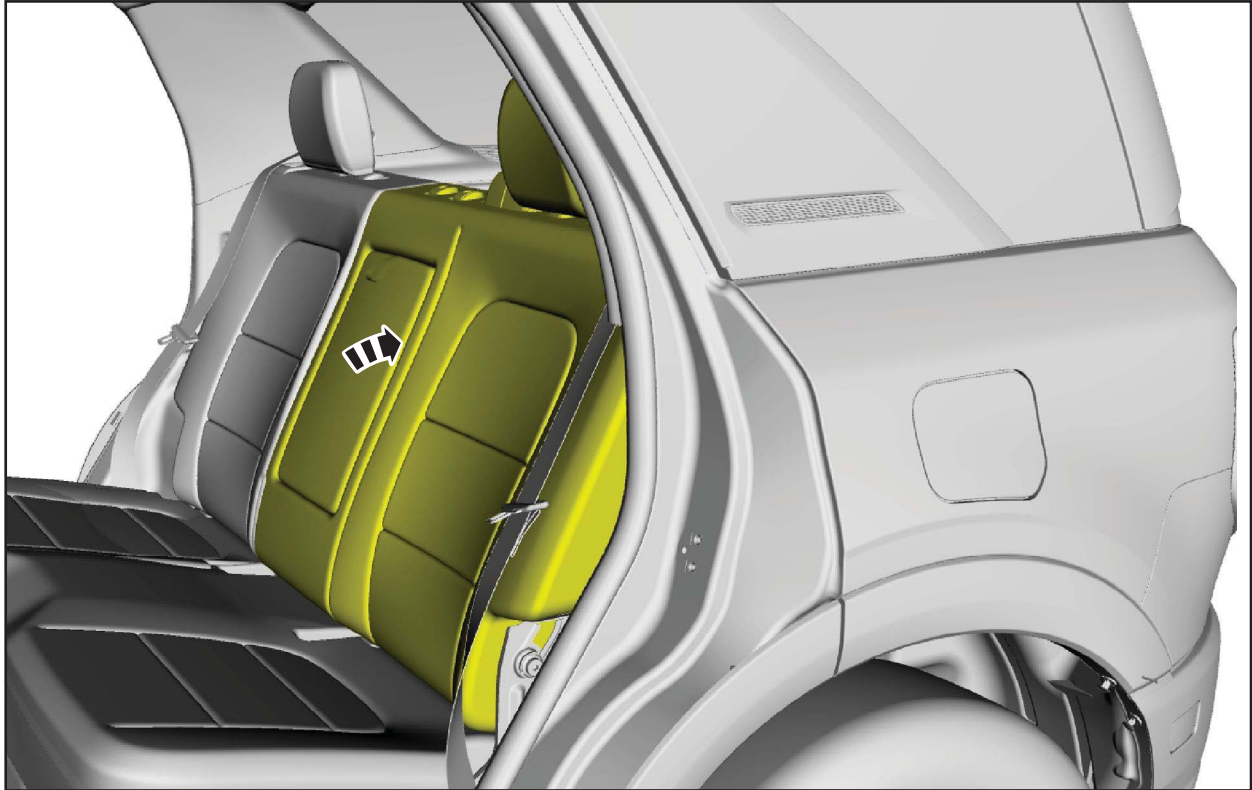

**FIGURE 24**





FORD PERFORMANCE

M-15200K-CXR  
2021 Bronco Sport Off-Road  
Roof-Mounted LED Light Bar

NO PART OF THIS DOCUMENT MAY BE REPRODUCED WITHOUT PRIOR AGREEMENT AND WRITTEN PERMISSION OF FORD PERFORMANCE PARTS

25. Remove the LH C-pillar trim panel bolt. See Figure 25.
- Torque: 80 lb.in (9 Nm)



FIGURE 25

**NOTE:** Use the General Equipment: Interior Trim Remover.

26. Release the LH C-pillar trim panel lower clips. See Figure 26.

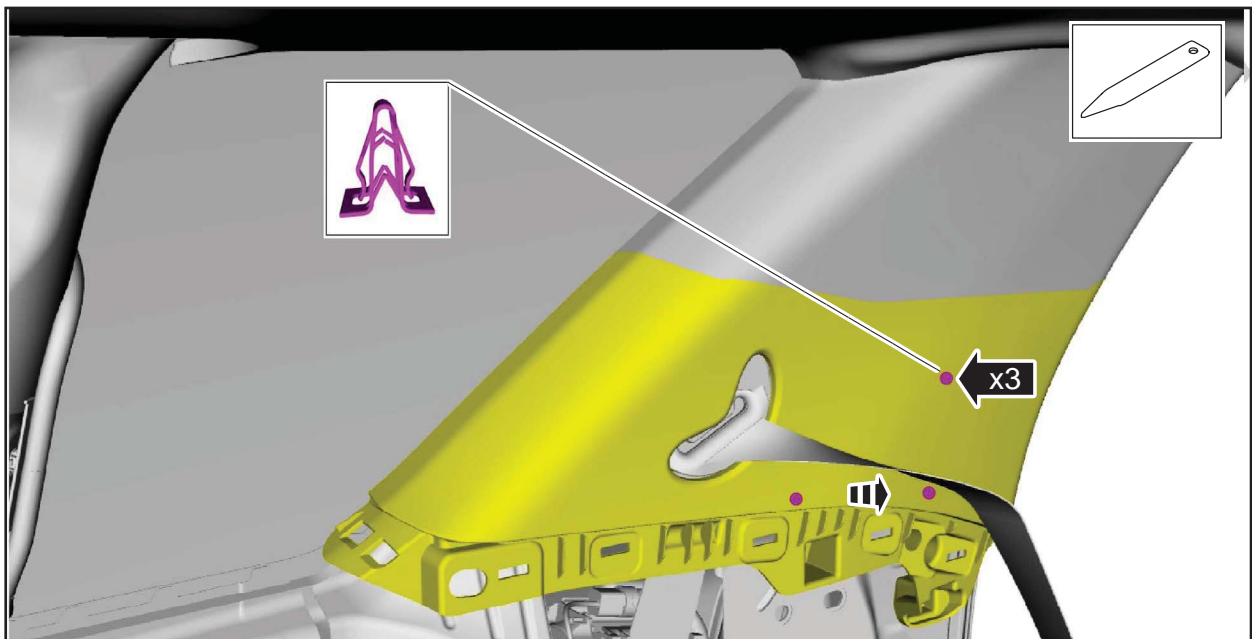

FIGURE 26

Ford Factory Shop Manual purchase options [www.motorcraftservice.com](http://www.motorcraftservice.com)



FORD PERFORMANCE

# M-15200K-CXR 2021 Bronco Sport Off-Road Roof-Mounted LED Light Bar

NO PART OF THIS DOCUMENT MAY BE REPRODUCED WITHOUT PRIOR AGREEMENT AND WRITTEN PERMISSION OF FORD PERFORMANCE PARTS

**NOTICE:** The C-pillar trim panel must be positioned upward to allow the upper clips to release correctly. Failure to follow this direction may cause damage to the C-pillar trim panel.

27. Slide the LH C-pillar trim panel up, aligning the clips to the slots in the sheet metal. See Figure 27.

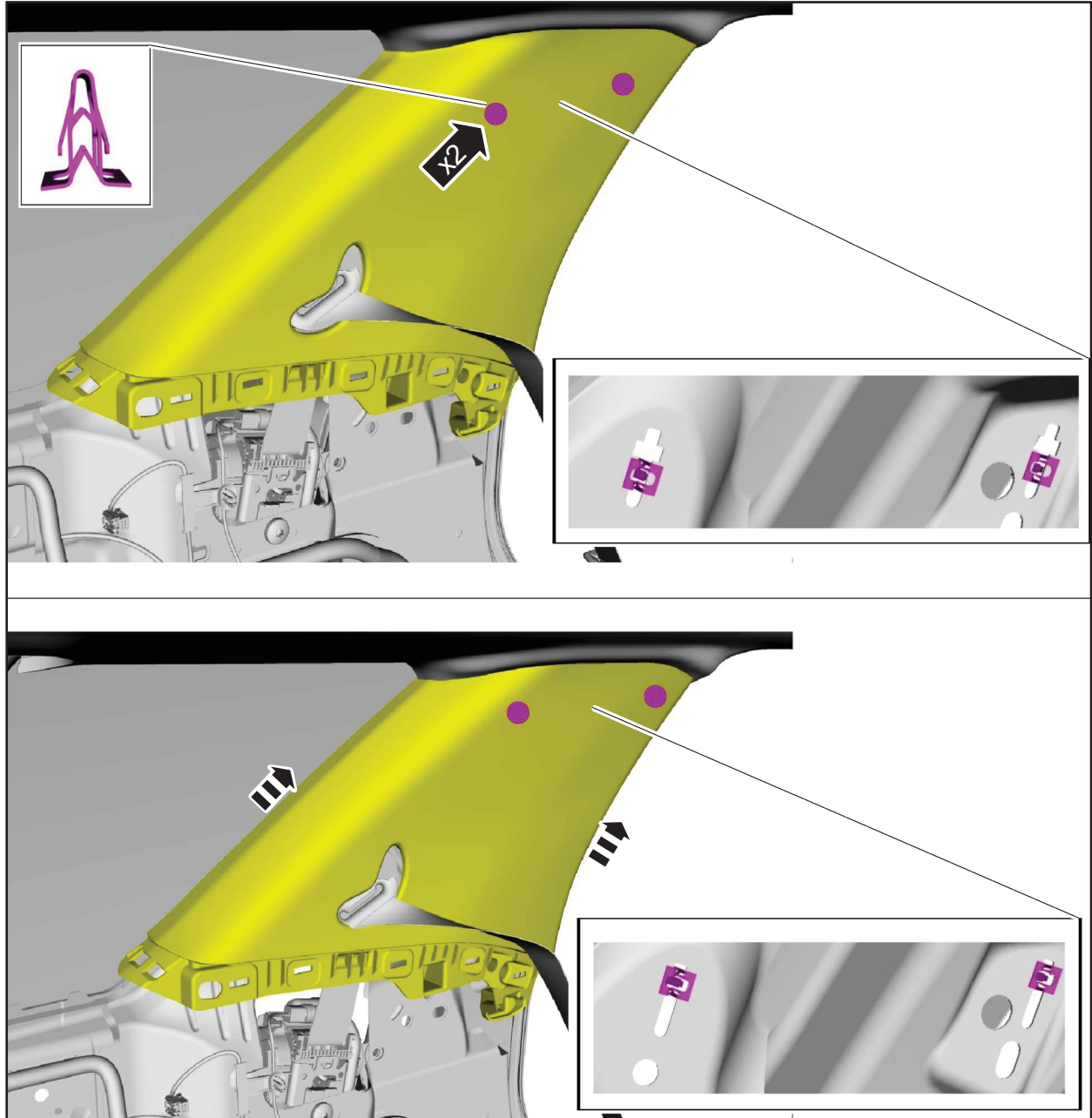

FIGURE 27

Ford Factory Shop Manual purchase options [www.motorcraftservice.com](http://www.motorcraftservice.com)

NO PART OF THIS DOCUMENT MAY BE REPRODUCED WITHOUT PRIOR AGREEMENT AND WRITTEN PERMISSION OF  
FORD PERFORMANCE PARTS

28. Position aside the LH C-pillar trim panel. See Figure 28.

1. Pull outward on the C-pillar trim panel.
2. Slide the C-pillar down the seat belt and out of the way.
3. Replace the two upper retention clips.

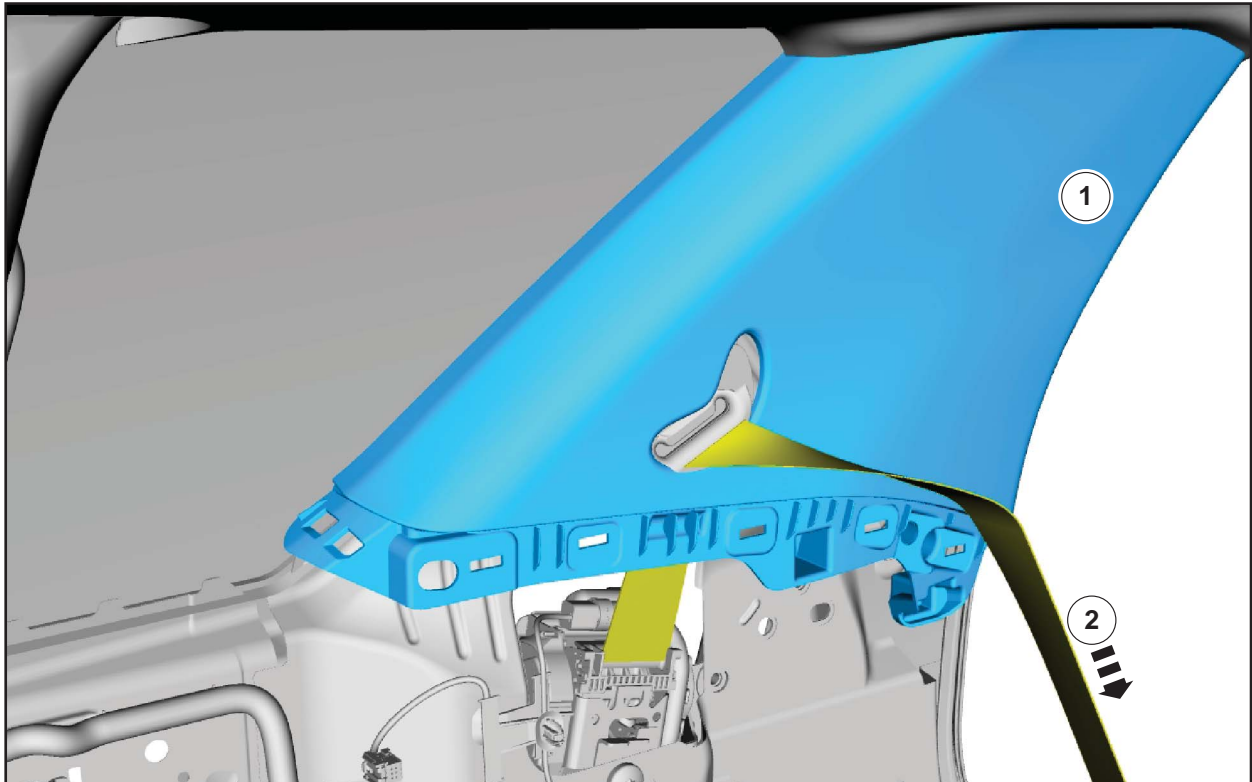

**FIGURE 28**



**FORD PERFORMANCE**

## M-15200K-CXR 2021 Bronco Sport Off-Road Roof-Mounted LED Light Bar

NO PART OF THIS DOCUMENT MAY BE REPRODUCED WITHOUT PRIOR AGREEMENT AND WRITTEN PERMISSION OF  
FORD PERFORMANCE PARTS

29. Remove the LH sun visor. See Figure 29.

1. Position the sun visor screw cover aside.
2. Remove the sun visor screw.
3. Rotate the sun visor downward.
4. If equipped, disconnect the sun visor electrical connector.

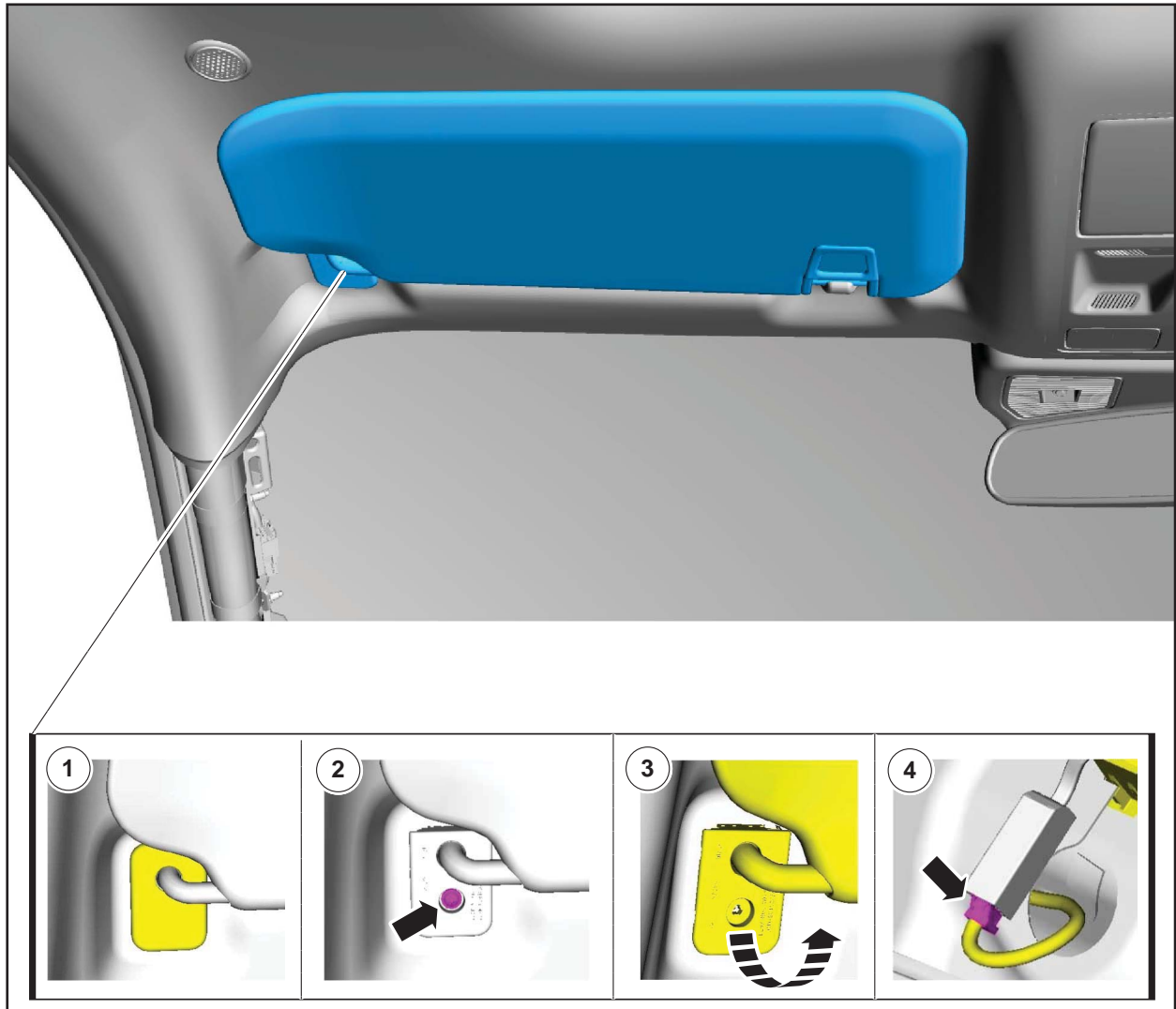

**FIGURE 29**

Ford Factory Shop Manual purchase options [www.motorcraftservice.com](http://www.motorcraftservice.com)





**FORD PERFORMANCE**

M-15200K-CXR  
2021 Bronco Sport Off-Road  
Roof-Mounted LED Light Bar

NO PART OF THIS DOCUMENT MAY BE REPRODUCED WITHOUT PRIOR AGREEMENT AND WRITTEN PERMISSION OF FORD PERFORMANCE PARTS

30. Remove the screw and the sun visor clip. See Figure 30.

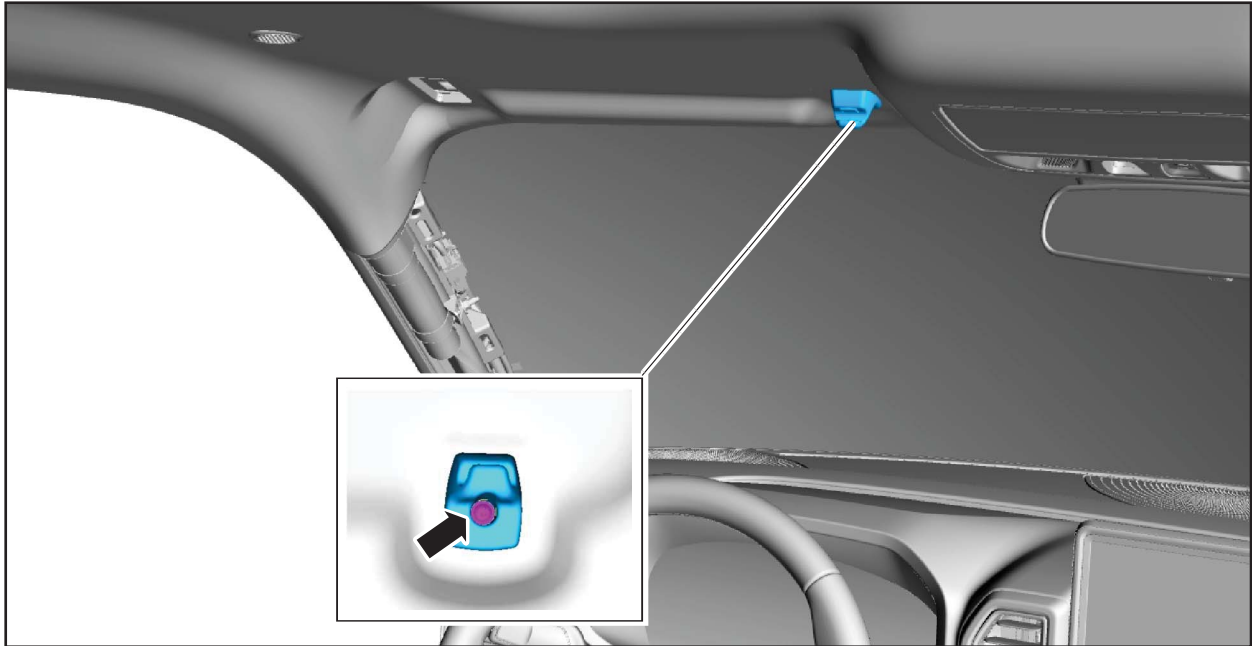

**FIGURE 30**

Ford Factory Shop Manual purchase options [www.motorcraftservice.com](http://www.motorcraftservice.com)

NO PART OF THIS DOCUMENT MAY BE REPRODUCED WITHOUT PRIOR AGREEMENT AND WRITTEN PERMISSION OF FORD PERFORMANCE PARTS

**NOTE:** Use the General Equipment: Interior Trim Remover.

31. Remove the LH rear assist handle. See Figure 31.

1. Position the rear assist handle down.
2. Remove the rear assist handle retainers.

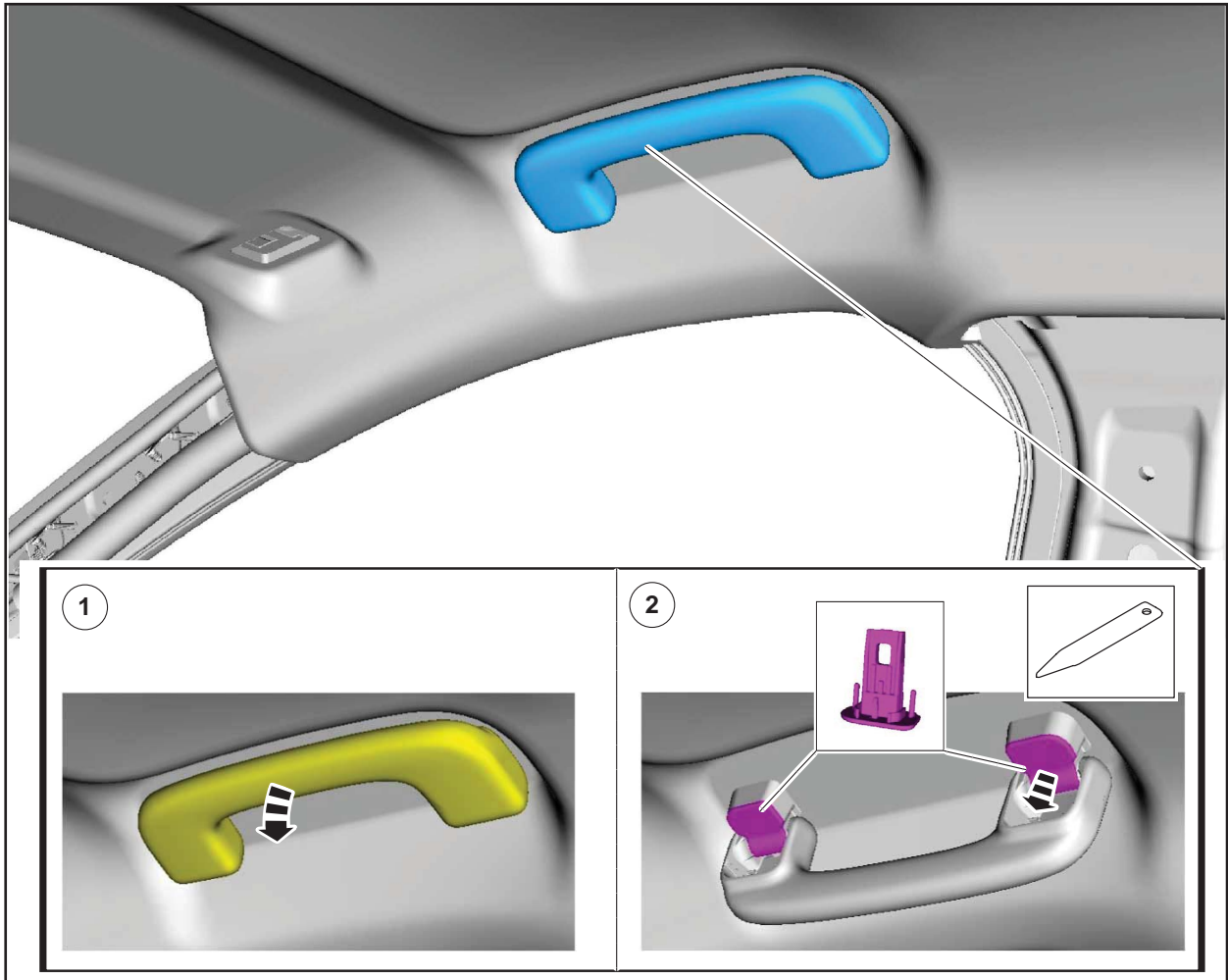
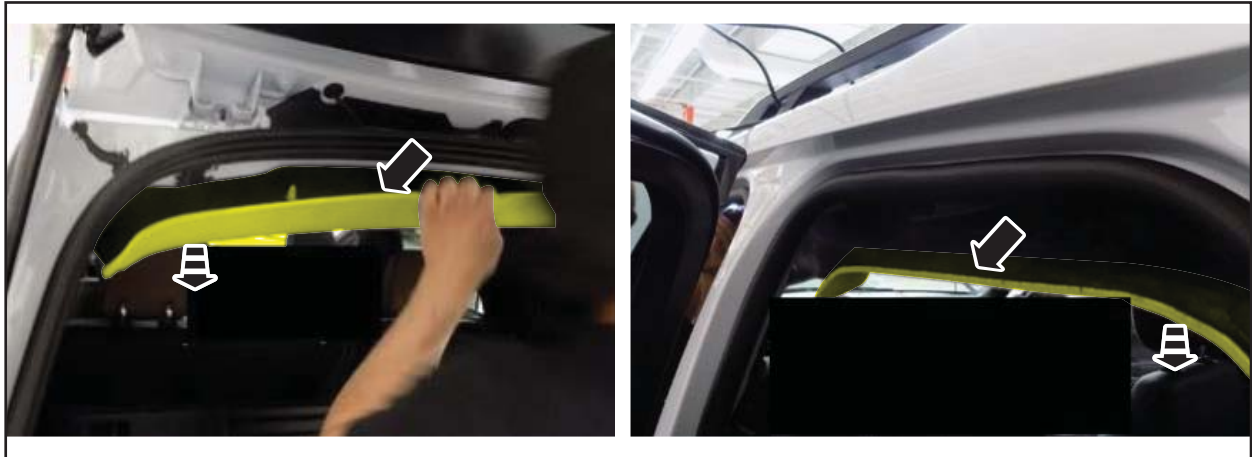

**FIGURE 31**

NO PART OF THIS DOCUMENT MAY BE REPRODUCED WITHOUT PRIOR AGREEMENT AND WRITTEN PERMISSION OF FORD PERFORMANCE PARTS

**NOTE:** Do not bend or crease the headliner.

32. Release the clips and magnets, then lower the LH side of the headliner. See Figure 32.



**FIGURE 32**

33. Remove the LH side rail nuts from inside the vehicle. See Figure 33.

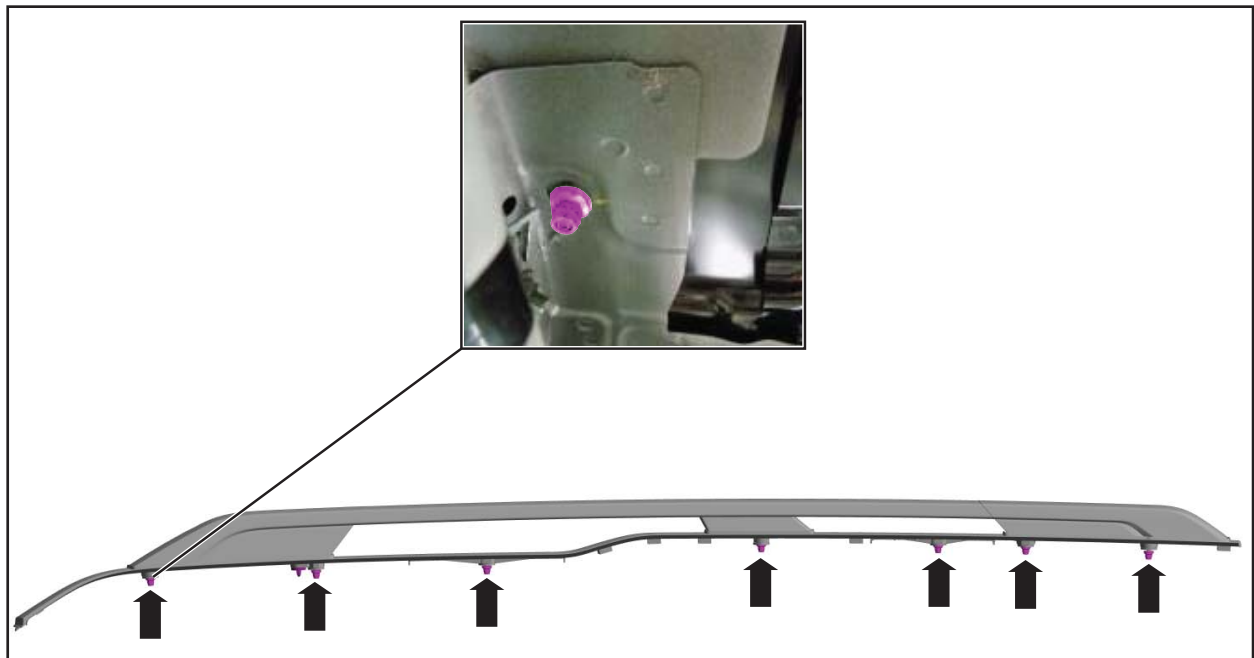

**FIGURE 33**

NO PART OF THIS DOCUMENT MAY BE REPRODUCED WITHOUT PRIOR AGREEMENT AND WRITTEN PERMISSION OF FORD PERFORMANCE PARTS

**NOTICE:** Use care not to break the tabs of the side rail.

34. Position upward the front portion of the LH side rail. See Figure 34.

1. Free the side rail from underneath the windshield.

**NOTE:** Polyurethane from the windshield might make removal difficult at first.

2. Partially remove side rail.
3. Snap the side rail out of the bracket.

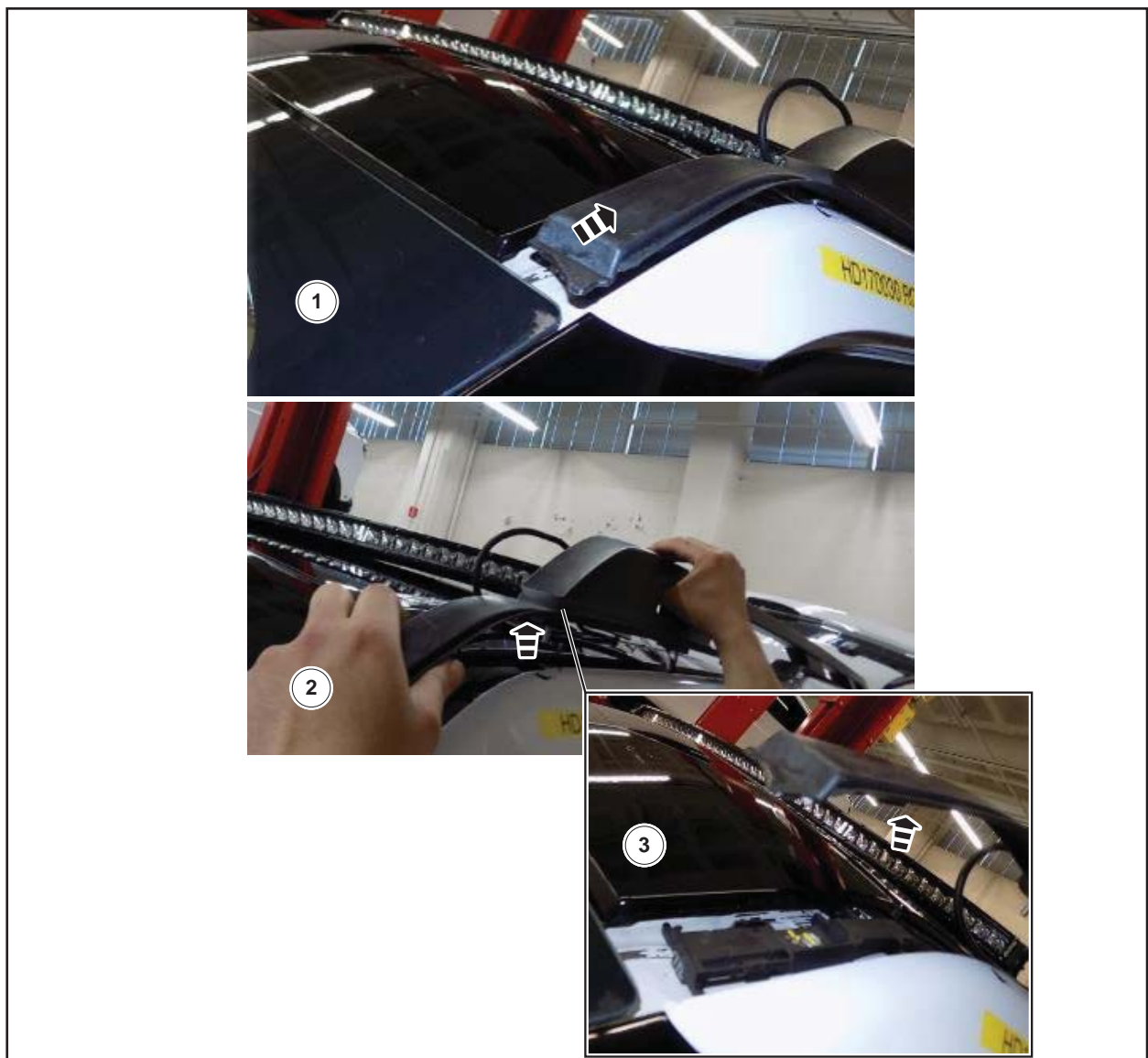

FIGURE 34



FORD PERFORMANCE

M-15200K-CXR  
2021 Bronco Sport Off-Road  
Roof-Mounted LED Light Bar

NO PART OF THIS DOCUMENT MAY BE REPRODUCED WITHOUT PRIOR AGREEMENT AND WRITTEN PERMISSION OF FORD PERFORMANCE PARTS

35. Drill Hole on side wall of the LH side rail using a 3/8 in (9.5mm) drill bit. See Figure 35.



FIGURE 35

36. Remove locating clip and enlarge hole using a 3/8 in (9.5 mm) drill bit. See Figure 36.

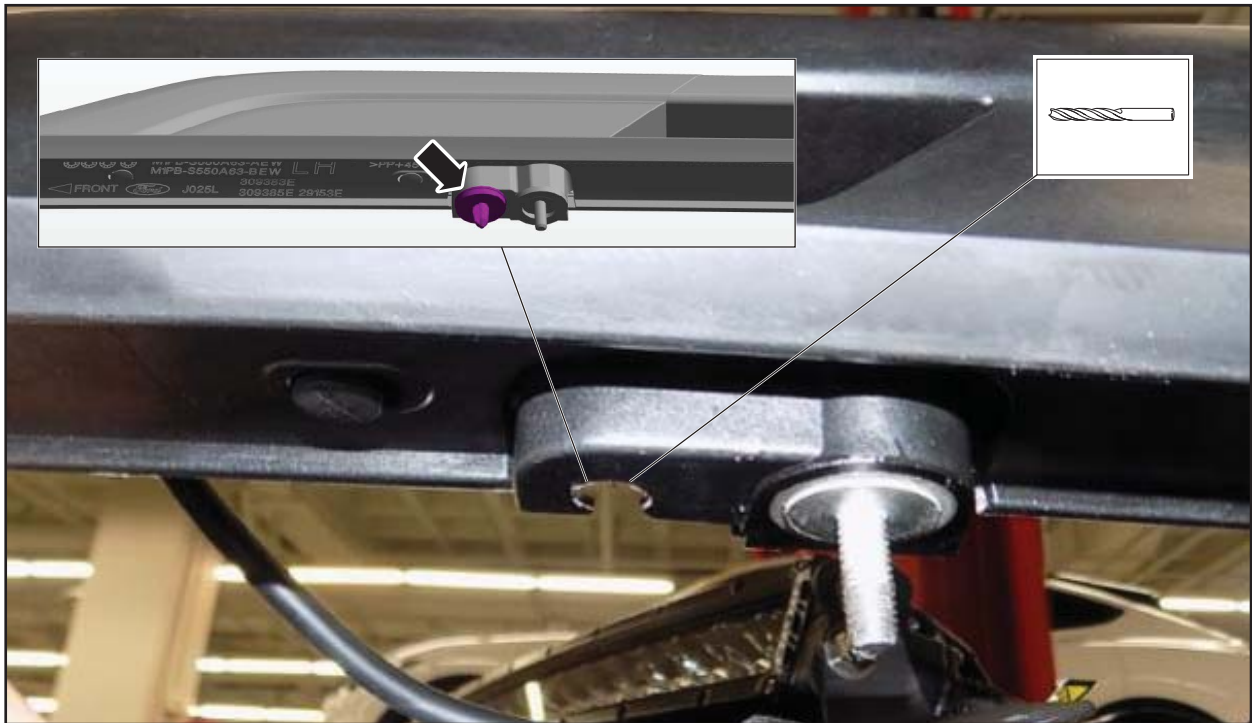

FIGURE 36

Ford Factory Shop Manual purchase options [www.motorcraftservice.com](http://www.motorcraftservice.com)





**FORD PERFORMANCE**

M-15200K-CXR  
2021 Bronco Sport Off-Road  
Roof-Mounted LED Light Bar

NO PART OF THIS DOCUMENT MAY BE REPRODUCED WITHOUT PRIOR AGREEMENT AND WRITTEN PERMISSION OF FORD PERFORMANCE PARTS

37. Use existing locator pin hole to route the wiring from the roof to the vehicle interior. Add silicone around hole to prevent water leaks into the vehicle. See Figure 37.

**NOTE:** Make sure that the wire length is long enough to secure the LED bar in place before fixing the side rail.



**FIGURE 37**

38. Check that the length is long enough to mount the light bar. See Figure 38.

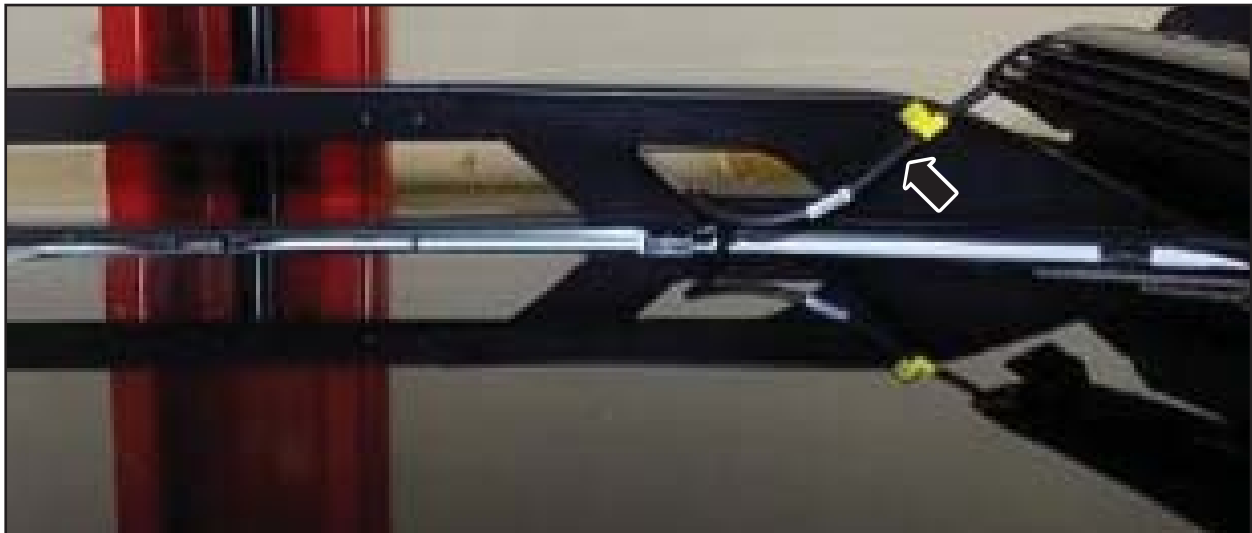

**FIGURE 38**

Ford Factory Shop Manual purchase options [www.motorcraftservice.com](http://www.motorcraftservice.com)



FORD PERFORMANCE

# M-15200K-CXR 2021 Bronco Sport Off-Road Roof-Mounted LED Light Bar

NO PART OF THIS DOCUMENT MAY BE REPRODUCED WITHOUT PRIOR AGREEMENT AND WRITTEN PERMISSION OF FORD PERFORMANCE PARTS

39. Detach the clips and Remove the LH side of the steering column cover. See Figure 39.

1. Detach the clips.
2. Disconnect the electrical connector.
3. Remove the LH side steering column cover.

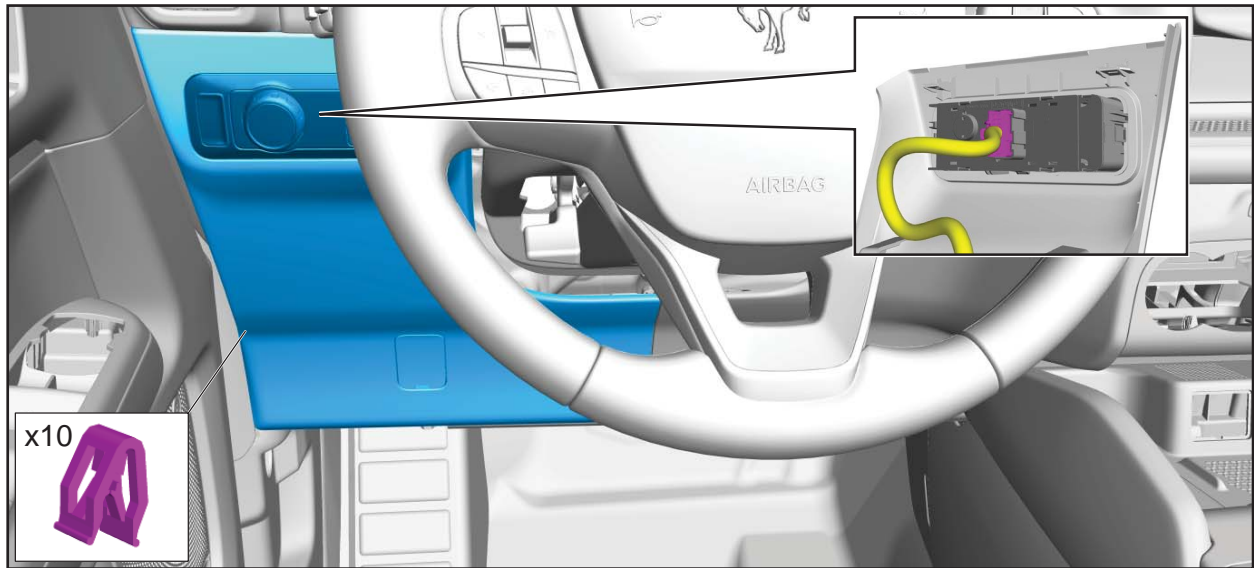

FIGURE 39

40. Install the lightbar switch. See Figure 40.

1. Drill a hole into the LH steering column cover using a 3/4 in (19 mm) drill bit.
2. Insert the switch into the new hole until you hear a click.

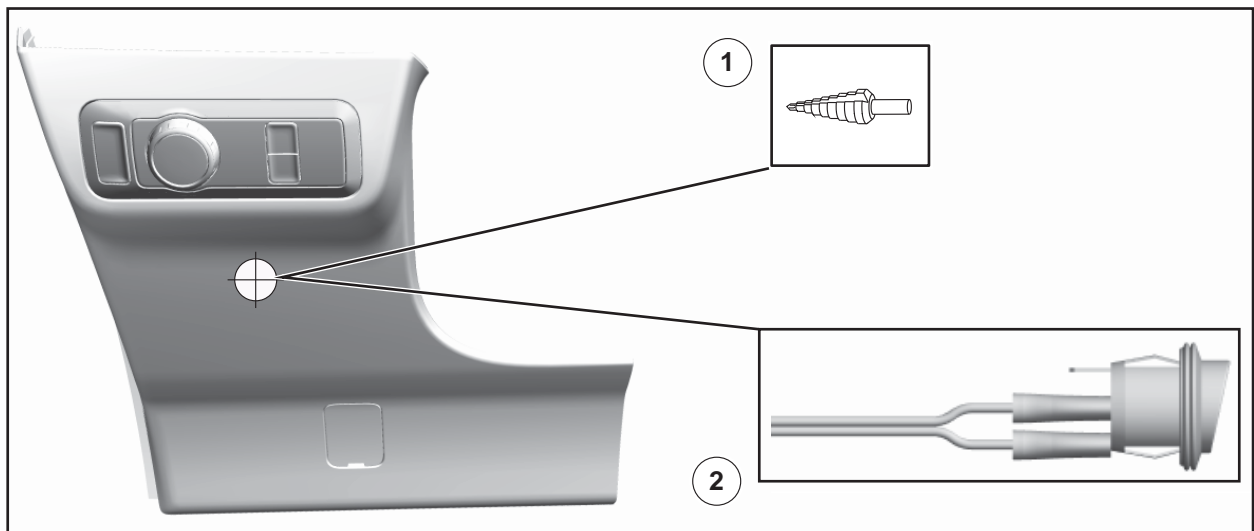

FIGURE 40

Ford Factory Shop Manual purchase options [www.motorcraftservice.com](http://www.motorcraftservice.com)



**FORD PERFORMANCE**

M-15200K-CXR  
2021 Bronco Sport Off-Road  
Roof-Mounted LED Light Bar

NO PART OF THIS DOCUMENT MAY BE REPRODUCED WITHOUT PRIOR AGREEMENT AND WRITTEN PERMISSION OF  
FORD PERFORMANCE PARTS

41. Route the wiring from the light bar downwards along the LH A-pillar. See Figure 41.

1. Secure to the existing harness using tie straps.

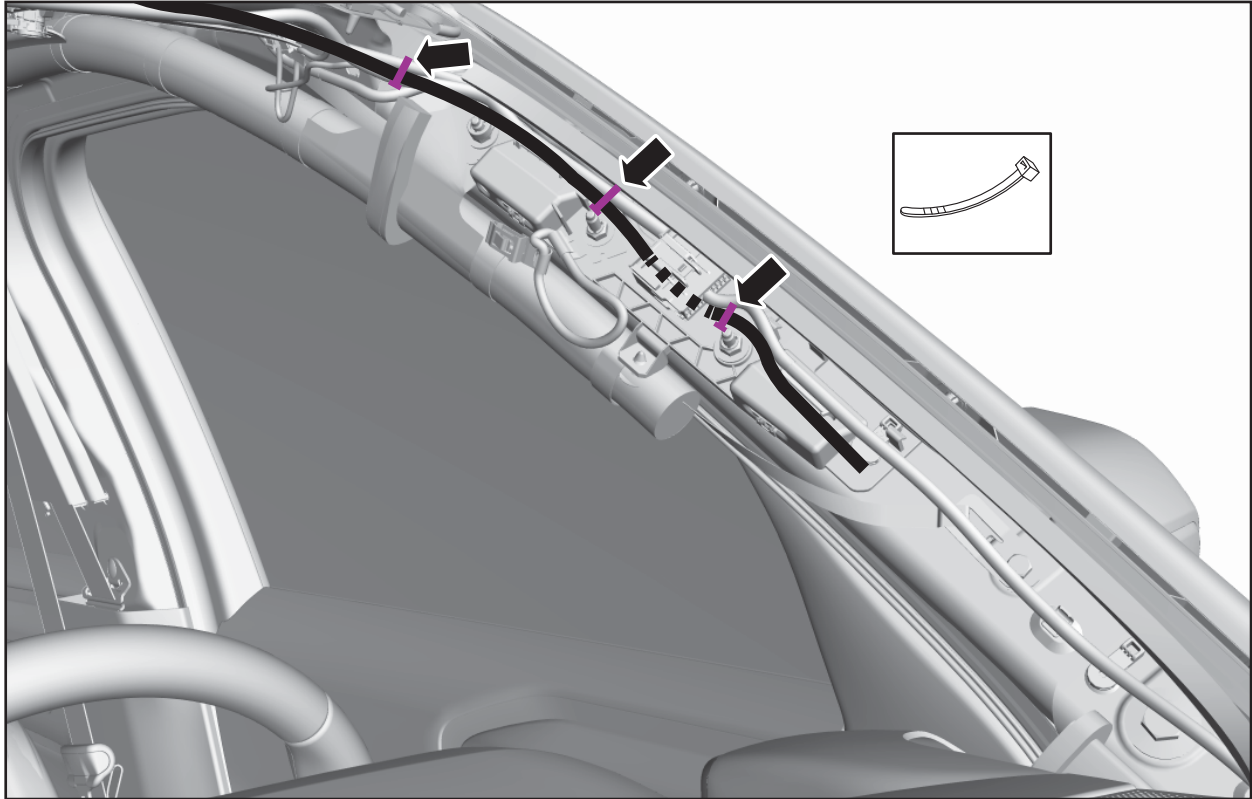

**FIGURE 41**

NO PART OF THIS DOCUMENT MAY BE REPRODUCED WITHOUT PRIOR AGREEMENT AND WRITTEN PERMISSION OF  
FORD PERFORMANCE PARTS

42. Connect the light bar to the A-pillar wiring. See Figure 42.

1. Remove the heat shrink on the A-pillar wiring. Use the provided splice kit WT-56815 for splicing.
2. Apply heat shrink tubing.
3. Crimp the wires to the matching color.
4. Position heat shrink tube over the crimp and heat.



**FIGURE 42**





FORD PERFORMANCE

M-15200K-CXR  
2021 Bronco Sport Off-Road  
Roof-Mounted LED Light Bar

NO PART OF THIS DOCUMENT MAY BE REPRODUCED WITHOUT PRIOR AGREEMENT AND WRITTEN PERMISSION OF FORD PERFORMANCE PARTS

43. Position back the LH Side rail. See Figure 43.

1. Position back the LH side rail tab under the windshield.
2. Position back the LH side rail and align the lightbar wiring to the slot in the side rail.
3. Add silicone around hole and lightbar wire to prevent water leaks into the vehicle.



FIGURE 43

**NOTE:** Do not attach or secure the wiring bundle to the side curtain airbag or wiring.

44. Secure the wiring bundle away from the side curtain airbag. See Figure 44.



FIGURE 44

Ford Factory Shop Manual purchase options [www.motorcraftservice.com](http://www.motorcraftservice.com)



**FORD PERFORMANCE**

# M-15200K-CXR 2021 Bronco Sport Off-Road Roof-Mounted LED Light Bar

NO PART OF THIS DOCUMENT MAY BE REPRODUCED WITHOUT PRIOR AGREEMENT AND WRITTEN PERMISSION OF FORD PERFORMANCE PARTS

45. Install the LH side rail nuts from inside the vehicle. See Figure 45.

- Torque: 97 lb. in (11 Nm)

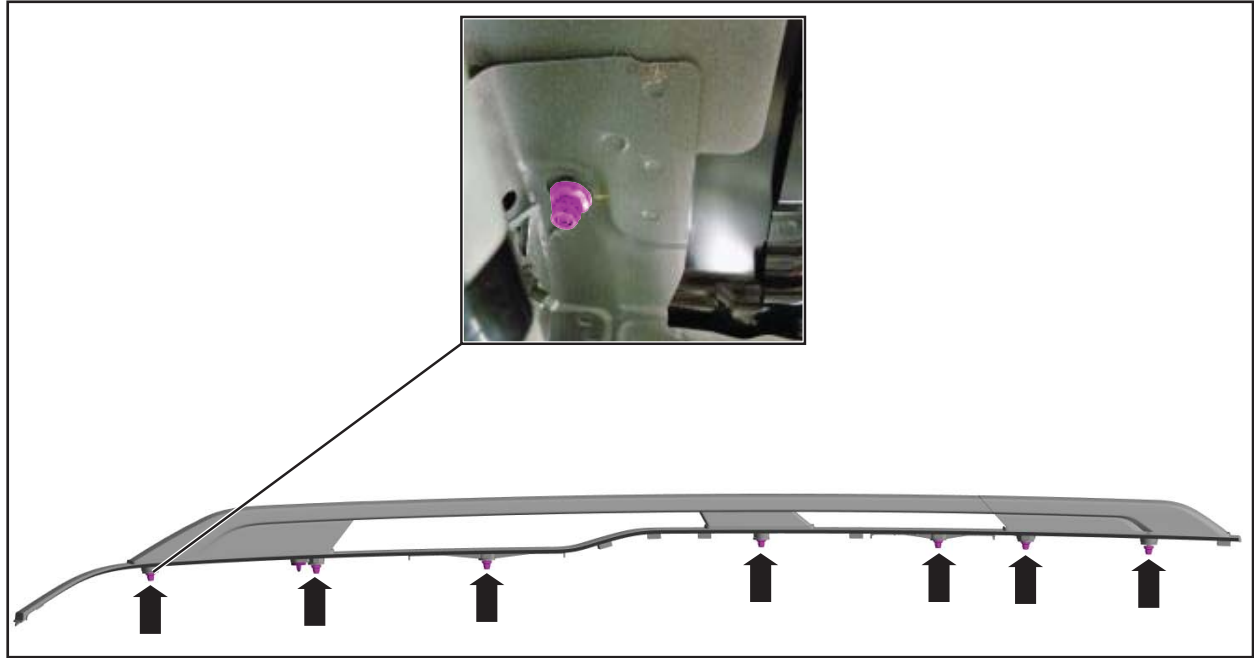

**FIGURE 45**



FORD PERFORMANCE

# M-15200K-CXR 2021 Bronco Sport Off-Road Roof-Mounted LED Light Bar

NO PART OF THIS DOCUMENT MAY BE REPRODUCED WITHOUT PRIOR AGREEMENT AND WRITTEN PERMISSION OF FORD PERFORMANCE PARTS

46. Attach the light bar mounting bracket. See Figure 46.

1. Insert the bolt head into the light bar.
2. Install the bolt cover.
3. Install the mounting bracket.
4. Install the washer.
5. Install the nut.

- Torque: ?? ft. lb (?? Nm)

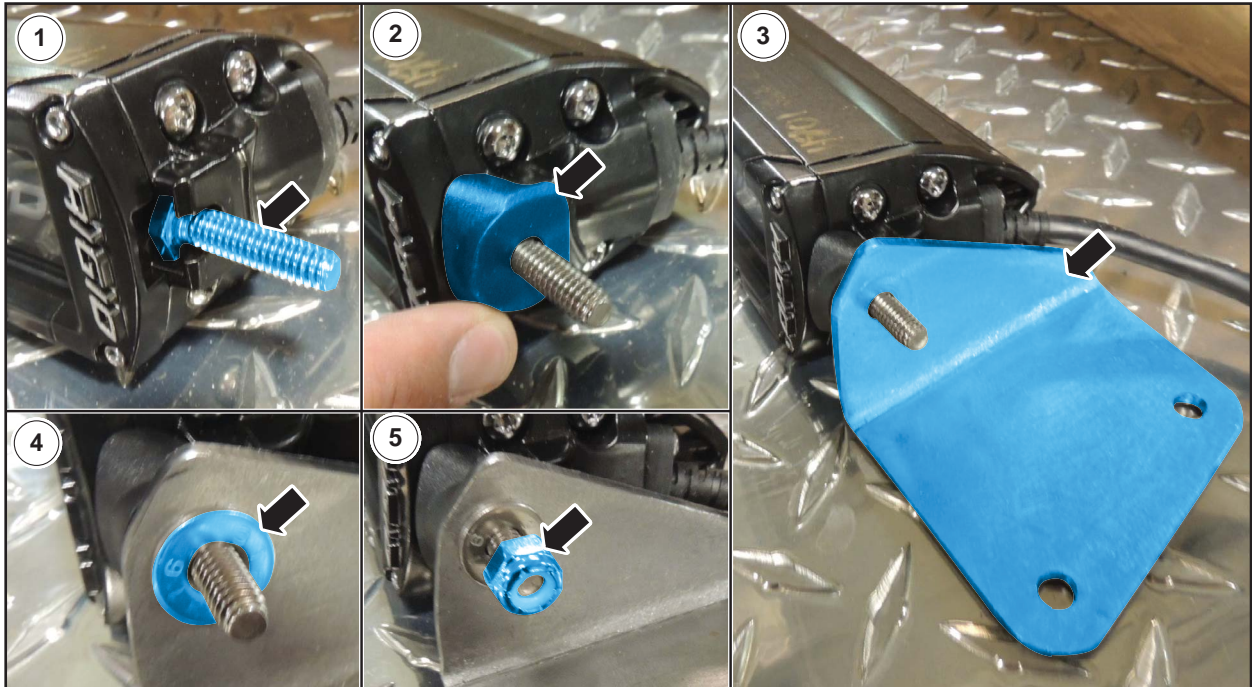

FIGURE 46

Ford Factory Shop Manual purchase options [www.motorcraftservice.com](http://www.motorcraftservice.com)



**FORD PERFORMANCE**

M-15200K-CXR  
2021 Bronco Sport Off-Road  
Roof-Mounted LED Light Bar

NO PART OF THIS DOCUMENT MAY BE REPRODUCED WITHOUT PRIOR AGREEMENT AND WRITTEN PERMISSION OF FORD PERFORMANCE PARTS

47. Position the light bar onto the side rails and mark the holes for drilling. See Figure 47.

1. Hold the light bar in position on the side rails.
2. Measure 2 in (50 mm) from the base of the side rail to the bottom of the light bar mounting bracket.
3. Mark the center of the light bar mounting bracket holes using a paint stick or center punch.
4. Remove the light bar from the side rails.
5. Using a  $\frac{23}{64}$  in (9 mm) drill bit, drill through the marks made on the top of the side rails.

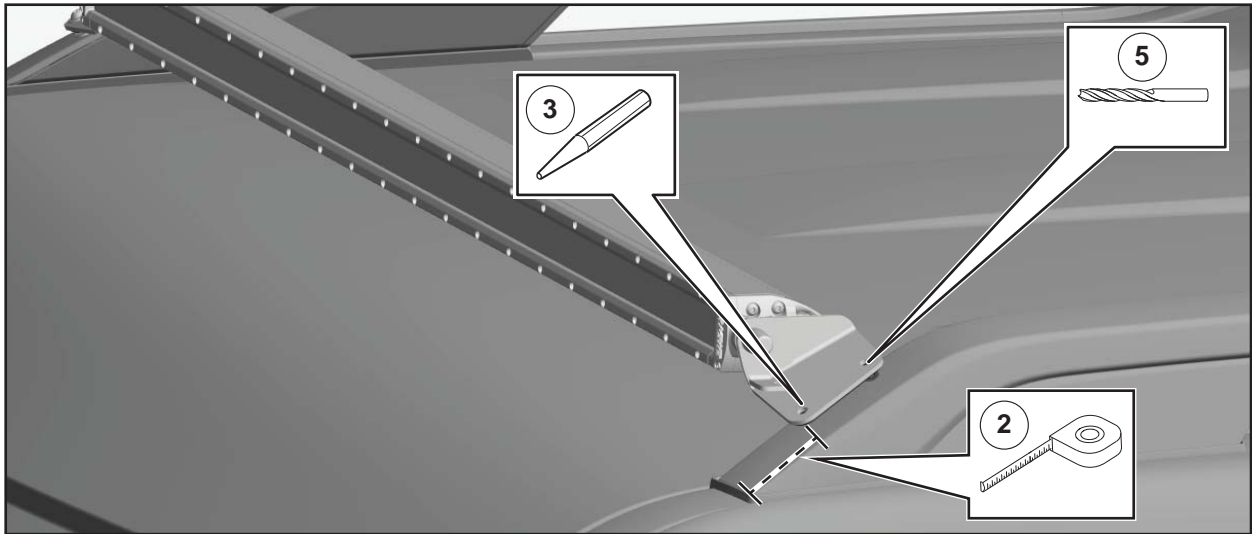

**FIGURE 47**

Ford Factory Shop Manual purchase options [www.motorcraftservice.com](http://www.motorcraftservice.com)





**FORD PERFORMANCE**

M-15200K-CXR  
2021 Bronco Sport Off-Road  
Roof-Mounted LED Light Bar

NO PART OF THIS DOCUMENT MAY BE REPRODUCED WITHOUT PRIOR AGREEMENT AND WRITTEN PERMISSION OF  
FORD PERFORMANCE PARTS

48. Install the supplied rivnut into the hole drilled into the side rail. See figure 48.



**FIGURE 48**

Ford Factory Shop Manual purchase options [www.motorcraftservice.com](http://www.motorcraftservice.com)



**FORD PERFORMANCE**

M-15200K-CXR  
2021 Bronco Sport Off-Road  
Roof-Mounted LED Light Bar

NO PART OF THIS DOCUMENT MAY BE REPRODUCED WITHOUT PRIOR AGREEMENT AND WRITTEN PERMISSION OF FORD PERFORMANCE PARTS

49. Install the light bar using the supplied bolts and washers. See Figure 49.



**FIGURE 49**

50. Install the light bar rubber caps. See Figure 50.

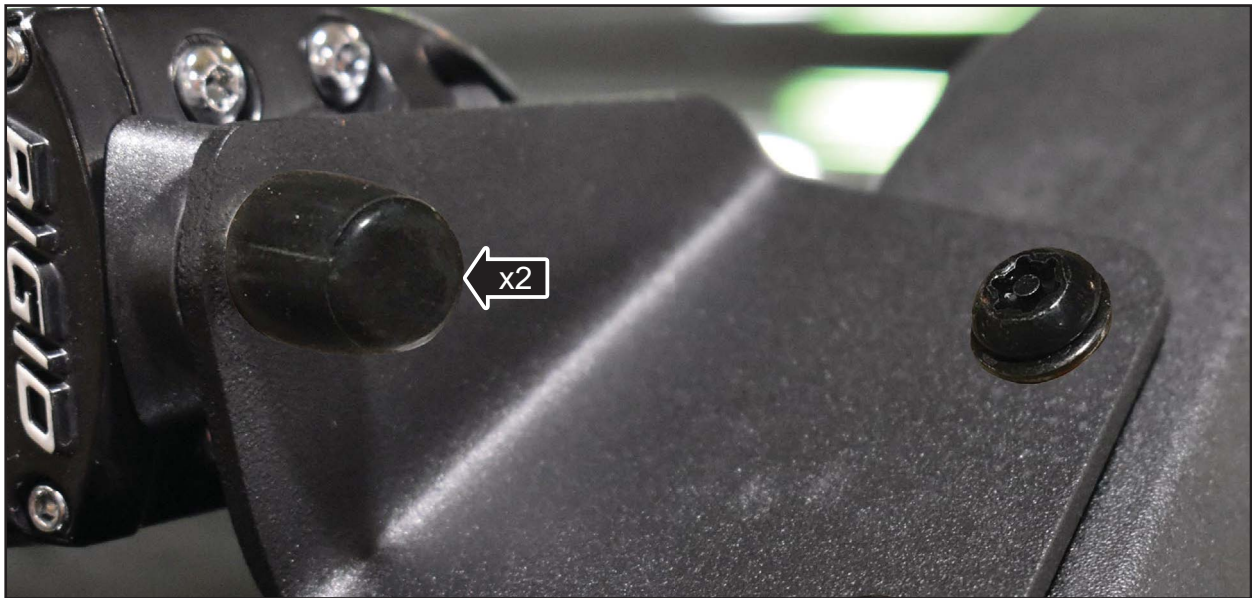

**FIGURE 50**

Ford Factory Shop Manual purchase options [www.motorcraftservice.com](http://www.motorcraftservice.com)

NO PART OF THIS DOCUMENT MAY BE REPRODUCED WITHOUT PRIOR AGREEMENT AND WRITTEN PERMISSION OF FORD PERFORMANCE PARTS

51. Connect the light bar switch to the instrument panel wiring. See Figure 51.

1. Remove the heat shrink on the instrument panel wiring.
2. Apply heat shrink tubing.
3. Crimp the White wire on the instrument panel harness to the Blue wire on the switch wiring.
4. Crimp the Yellow-Green wire on the instrument panel harness to the Red wire on the switch wiring.
5. Position heat shrink tube over the crimp and heat.

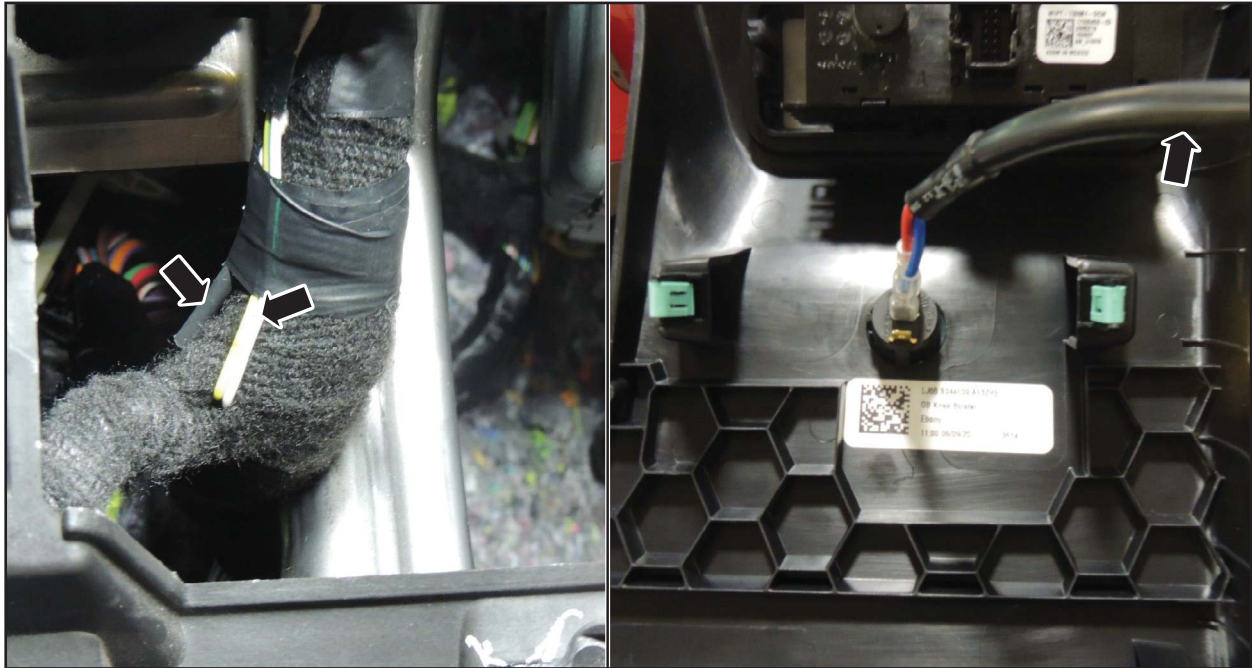

**FIGURE 51**





**FORD PERFORMANCE**

M-15200K-CXR  
2021 Bronco Sport Off-Road  
Roof-Mounted LED Light Bar

NO PART OF THIS DOCUMENT MAY BE REPRODUCED WITHOUT PRIOR AGREEMENT AND WRITTEN PERMISSION OF  
FORD PERFORMANCE PARTS

52. Install the LH steering column trim panel. See Figure 52.

1. Connect the electrical connector of the headlamp switch.
2. Install the LH steering column trim panel by attaching the clips.

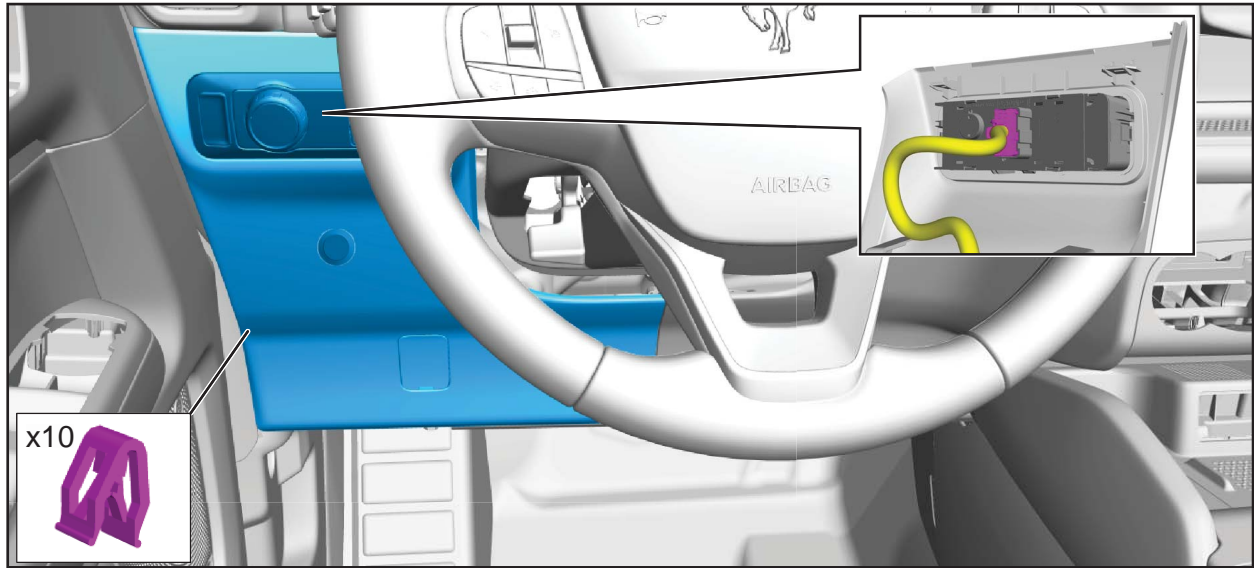

**FIGURE 52**

53. Assemble the rest of the vehicle by reversing the disassembly procedures.