



M-16601-M65PP
2024+MY Mustang EcoBoost & GT
Performance Pack Splitter

NO PART OF THIS DOCUMENT MAY BE REPRODUCED WITHOUT PRIOR AGREEMENT AND WRITTEN PERMISSION OF
FORD PERFORMANCE PARTS © Ford Motor Company 2020

PRIOR TO INSTALLATION READ THESE INSTRUCTIONS COMPLETELY
For questions, Call the FORD PERFORMANCE Techline 1-800-367-3788

Please visit <https://www.performanceparts.ford.com> for warranty information



Ford Factory Shop Manual purchase options www.motorcraftservice.com

NO PART OF THIS DOCUMENT MAY BE REPRODUCED WITHOUT PRIOR AGREEMENT AND WRITTEN PERMISSION OF FORD PERFORMANCE PARTS © Ford Motor Company 2020

Removal

All vehicles

NOTE: Removal steps in this procedure may contain installation details.

1. Remove the front wheels and tires.
2. On both sides.
Remove and save the bolts and the body side front shield.
Torque: 19 lb.in (2.2 Nm)

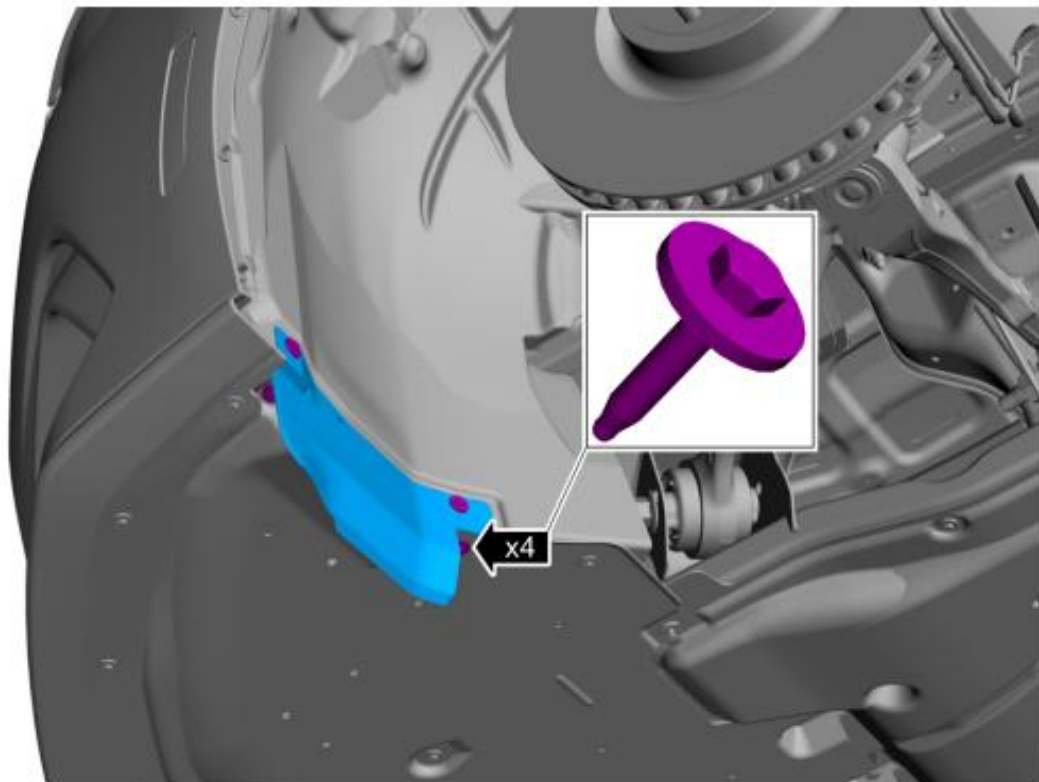

E407403

Ford Factory Shop Manual purchase options www.motorcraftservice.com

NO PART OF THIS DOCUMENT MAY BE REPRODUCED WITHOUT PRIOR AGREEMENT AND WRITTEN PERMISSION OF FORD PERFORMANCE PARTS © Ford Motor Company 2020

- On both sides.
Remove and save the push pins and position aside the front fender splash shield.

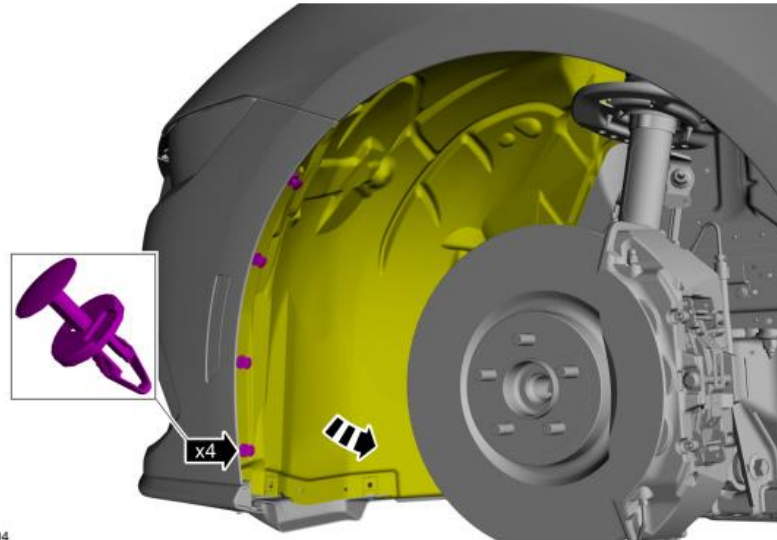

Vehicles With: GT Performance Package

- On both sides.
Remove and save the screws, push pins and position aside the front fender splash shield.
Torque: 19 lb.in (2.2 Nm)

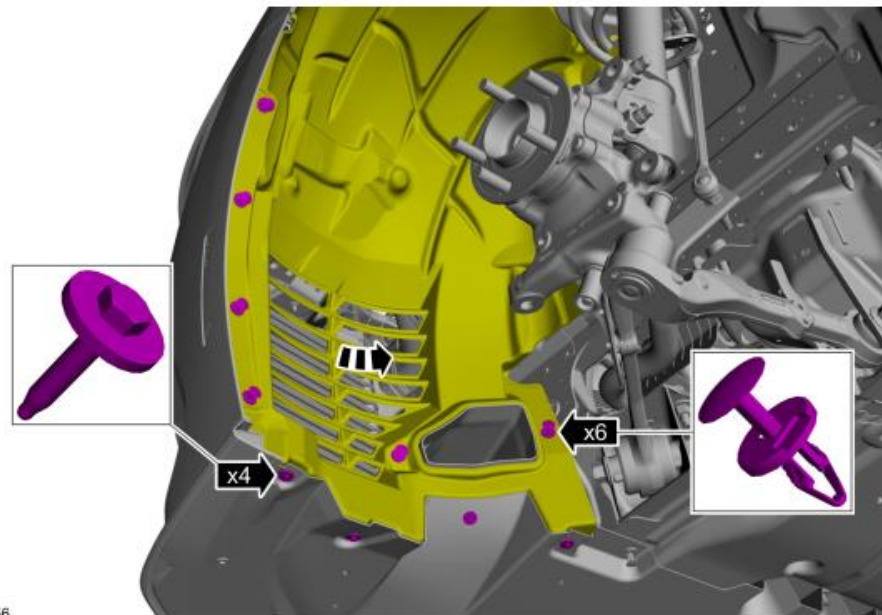

Ford Factory Shop Manual purchase options www.motorcraftservice.com



FORD PERFORMANCE

M-16601-M65PP 2024+MY Mustang EcoBoost & GT Performance Pack Splitter

NO PART OF THIS DOCUMENT MAY BE REPRODUCED WITHOUT PRIOR AGREEMENT AND WRITTEN PERMISSION OF FORD PERFORMANCE PARTS © Ford Motor Company 2020

All vehicles

5. Remove the bolts. New bolts are provided in the kit.
Torque: 19 lb.in (2.2 Nm)

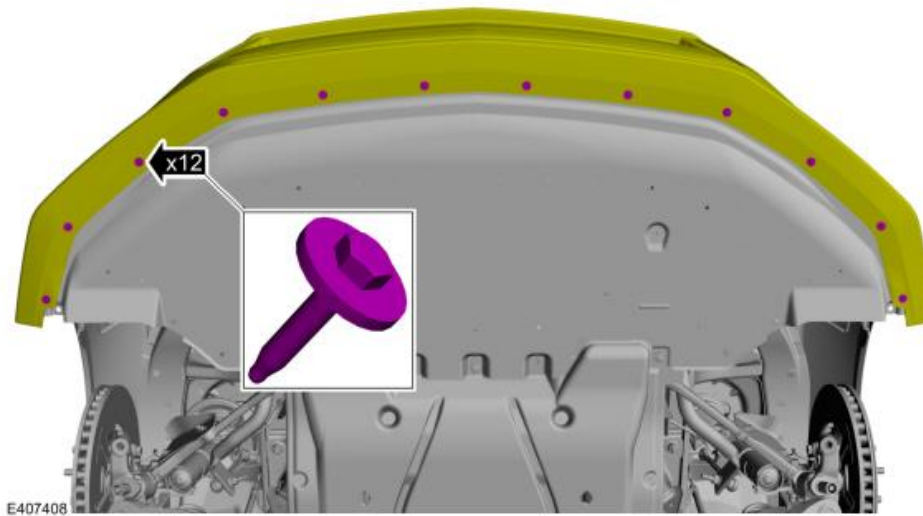

6. On both sides.
Disconnect the side repeater lamp electrical connector.

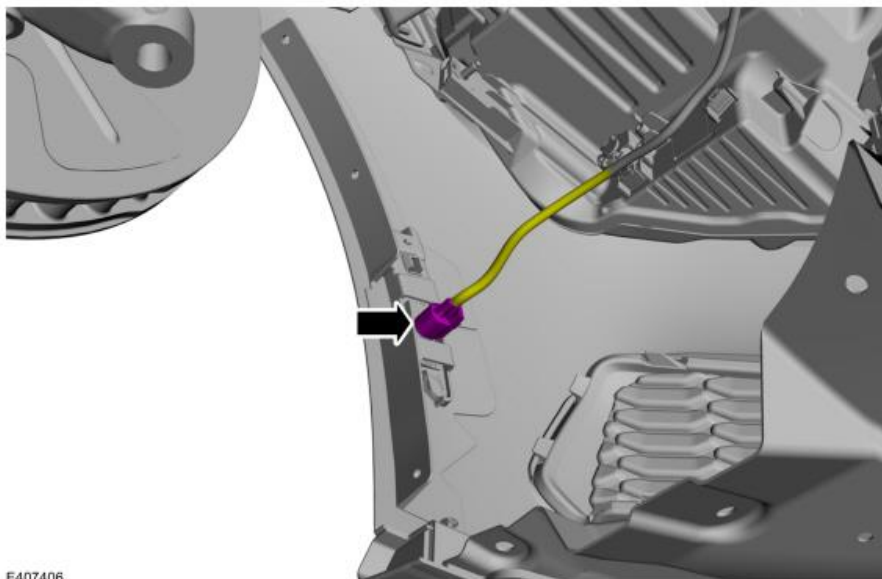

Ford Factory Shop Manual purchase options www.motorcraftservice.com

NO PART OF THIS DOCUMENT MAY BE REPRODUCED WITHOUT PRIOR AGREEMENT AND WRITTEN PERMISSION OF FORD PERFORMANCE PARTS © Ford Motor Company 2020

7. Disconnect the front bumper cover electrical connector.

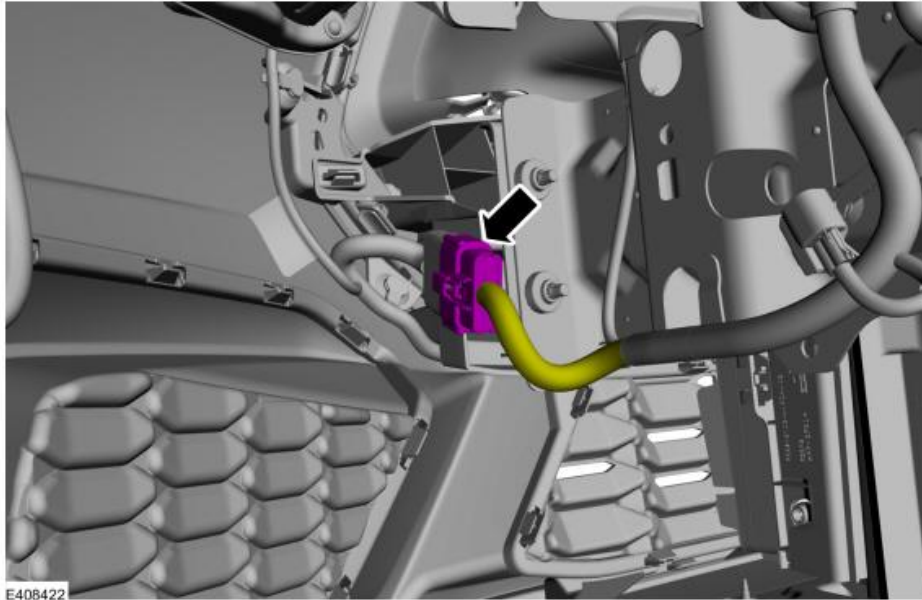

8. On both sides.
Remove and save the front bumper cover to fender push-pins and the bolts.
Torque: 44 lb.in (5 Nm)

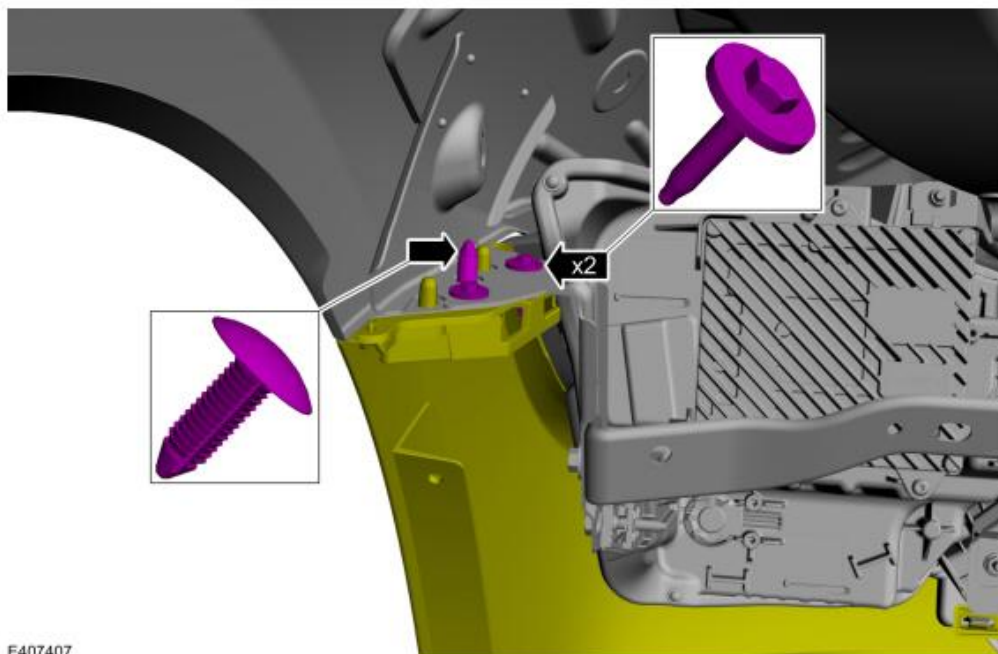

Ford Factory Shop Manual purchase options www.motorcraftservice.com

NO PART OF THIS DOCUMENT MAY BE REPRODUCED WITHOUT PRIOR AGREEMENT AND WRITTEN PERMISSION OF FORD PERFORMANCE PARTS © Ford Motor Company 2020

9. Remove and save the push pins and the radiator sight shield.

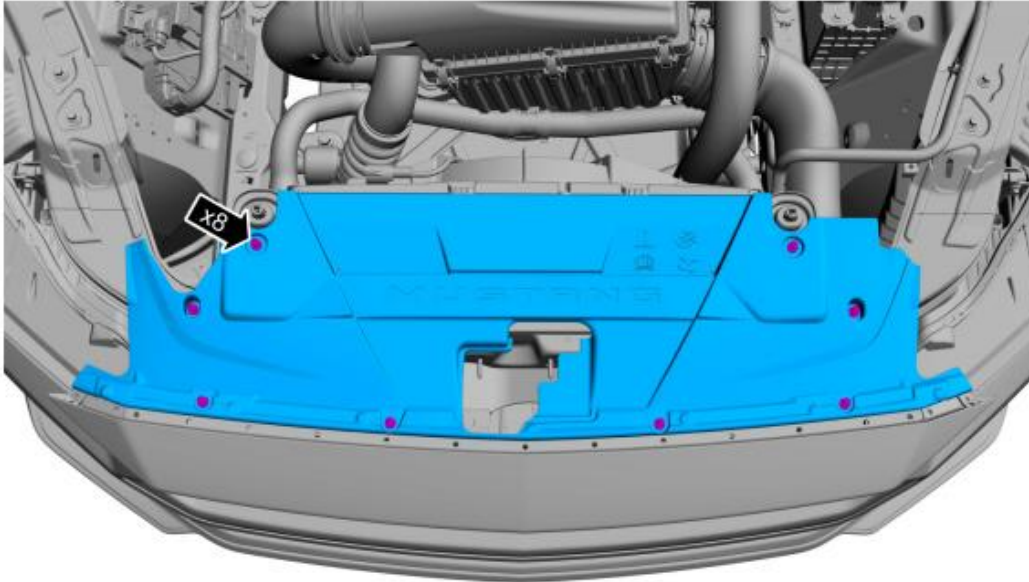

E407409

10. **NOTE:** This step requires the aid of another technician.

Remove and save the bolts and the front bumper cover.
Torque: 13 lb.in (1.5 Nm)

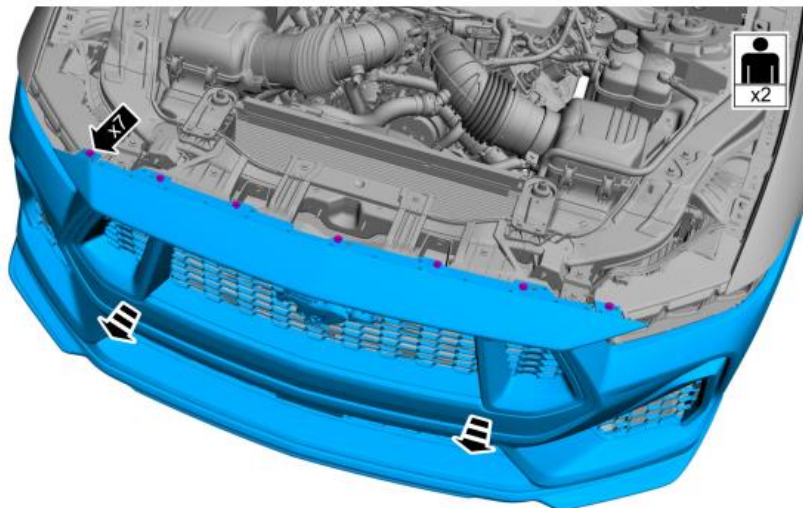

E407557

Ford Factory Shop Manual purchase options www.motorcraftservice.com

NO PART OF THIS DOCUMENT MAY BE REPRODUCED WITHOUT PRIOR AGREEMENT AND WRITTEN PERMISSION OF FORD PERFORMANCE PARTS © Ford Motor Company 2020

11. Remove and save the push pins, bolts, and the underbody shield.

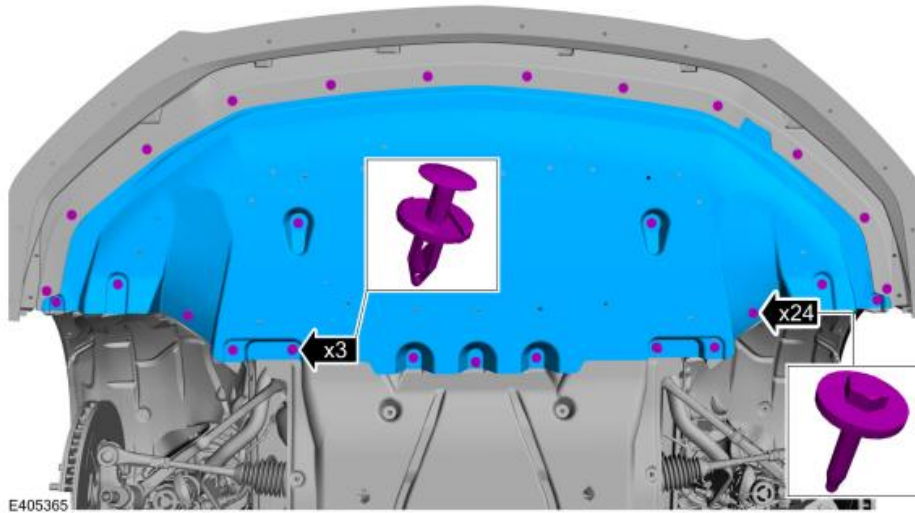

- 12.
1. Remove the bolts. New bolts are provided in the kit.
Torque: 15 lb.in (1.7 Nm)
 2. Remove the push pins. New push pins are provided in the kit.
 3. Release the tabs and remove the front bumper splitter.

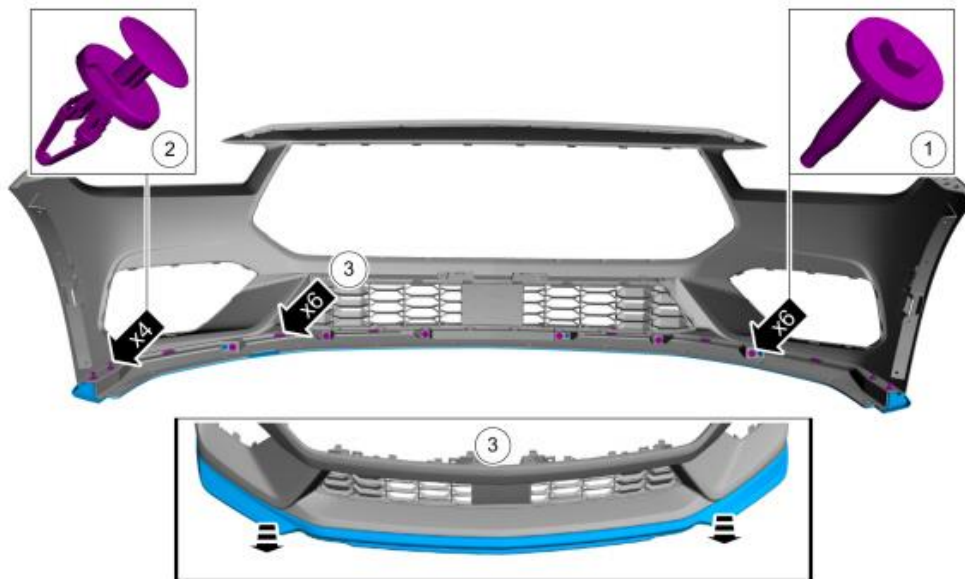

Ford Factory Shop Manual purchase options www.motorcraftservice.com



FORD PERFORMANCE

**M-16601-M65PP
2024+MY Mustang EcoBoost & GT
Performance Pack Splitter**

NO PART OF THIS DOCUMENT MAY BE REPRODUCED WITHOUT PRIOR AGREEMENT AND WRITTEN PERMISSION OF
FORD PERFORMANCE PARTS © Ford Motor Company 2020

Installation

1. Reverse the removal process.

Ford Factory Shop Manual purchase options www.motorcraftservice.com