



M-4033-G4
Mustang GT / GT350
8.8" IRS Axle Girdle Cover

NO PART OF THIS DOCUMENT MAY BE REPRODUCED WITHOUT PRIOR AGREEMENT AND WRITTEN PERMISSION OF
FORD PERFORMANCE PARTS © Ford Motor Company 2020

PRIOR TO INSTALLATION READ THESE INSTRUCTION COMPLETELY
For questions, Call the FORD PERFORMANCE Techline 1-800-367-3788

Please visit <https://www.performanceparts.ford.com> for warranty information



Kit Contents
Differential Cover Assembly
Nuts, Haft Shaft
TA-26

Note: A vehicle hoist is required for the installation of this kit. If you do not have one available, please seek out a professional mechanic for this installation.

Ford Factory Shop Manual purchase options www.motorcraftservice.com



M-4033-G4
Mustang GT / GT350
8.8" IRS Axle Girdle Cover

NO PART OF THIS DOCUMENT MAY BE REPRODUCED WITHOUT PRIOR AGREEMENT AND WRITTEN PERMISSION OF FORD PERFORMANCE PARTS © Ford Motor Company 2020

Fluid Requirements

Traction-Lok® & Torsen® Differentials, SAE 75w-85 Gear Lubricant, Motorcraft XY-75W85-QL, 1.65 qt
Differentials with Cooler, SAE 75w-85 Gear Lubricant, Motorcraft XY-75W85-QL, 2.06 qt
Traction-Lok® & Torsen® Differentials, Friction Modifier, M-19546-A12, 3-3.5 oz
Differentials with Cooler, Friction Modifier, M-19546-A12, 4-4.5 oz
See your owner's manual for details

Recommended Sealants

Motorcraft Silicone Gasket and Sealant, TA-29
Motorcraft Thread Sealer, TA-24-B

Recommended Thread Locking Compound

Motorcraft, TA-26

Recommended Motorcraft Cleaners

Silicone Gasket Remover, ZC-30-A
Metal Surface Prep Wipes, ZC-31-B
Metal Brake Parts Cleaner, PM-4-A or PM-4-B

Lifting Overview

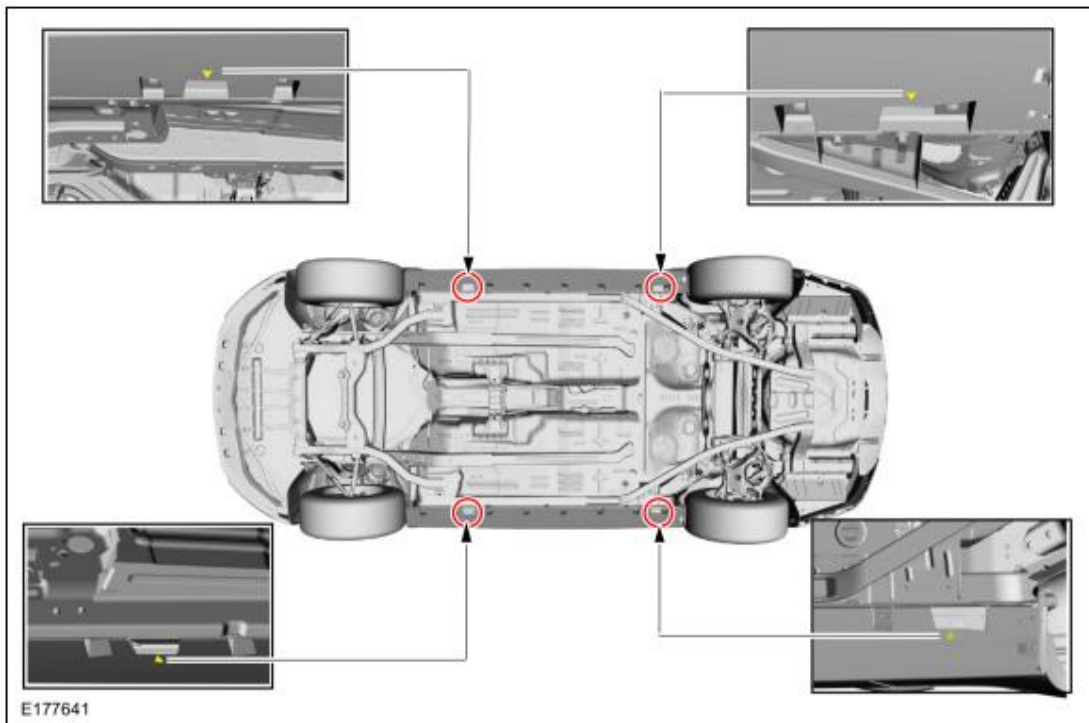

Ford Factory Shop Manual purchase options www.motorcraftservice.com

NO PART OF THIS DOCUMENT MAY BE REPRODUCED WITHOUT PRIOR AGREEMENT AND WRITTEN PERMISSION OF FORD PERFORMANCE PARTS © Ford Motor Company 2020

⚠ WARNING: Identify the correct jacking points by locating the triangle stamped into the uni-body sheet metal or vehicle frame. Raising a vehicle in any other location may result in vehicle shifting or falling. Failure to follow this instruction may result in serious personal injury.

⚠ WARNING: Never get underneath a vehicle that is supported only by a jack. The jack could unintentionally lower. Always support vehicle with floor stands. Failure to follow these instructions may result in serious personal injury.

NOTICE: The jack provided with the vehicle is intended to be used in an emergency for changing a deflated tire. To avoid damage to the vehicle, never use the jack to hoist the vehicle for any other purpose.

NOTICE: Do not attempt to use jack pressure on either the front bumper or the rear bumper on any vehicle. Damage to bumper covers will occur.

NOTICE: Damage to the suspension, exhaust or steering linkage components may occur if care is not exercised when positioning the hoist adapters prior to lifting the vehicle.

NOTICE: To prevent possible damage to the underbody, do not drive the vehicle onto the drive-on lift without first checking for possible interference.

NOTICE: When raising a vehicle on a two-column hoist, use care when positioning the vehicle so that the hoisting forks do not interfere with suspension components, mounting brackets or stabilizer mounting brackets, if equipped. In addition, use care in hoist positioning to avoid possible damage to the axle or rear cover.

Put vehicle on hoist per the Lifting Overview

Drain Differential

Vehicles without differential coolers

Remove the differential drain plug and drain the differential fluid.

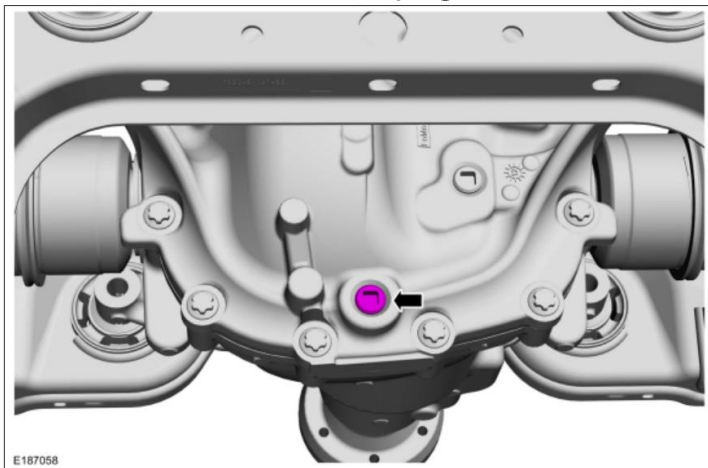

E187058

Ford Factory Shop Manual purchase options www.motorcraftservice.com

NO PART OF THIS DOCUMENT MAY BE REPRODUCED WITHOUT PRIOR AGREEMENT AND WRITTEN PERMISSION OF FORD PERFORMANCE PARTS © Ford Motor Company 2020

Vehicles with differential coolers

Remove deflector by removing bolts and push pins. All hardware is to be reused.

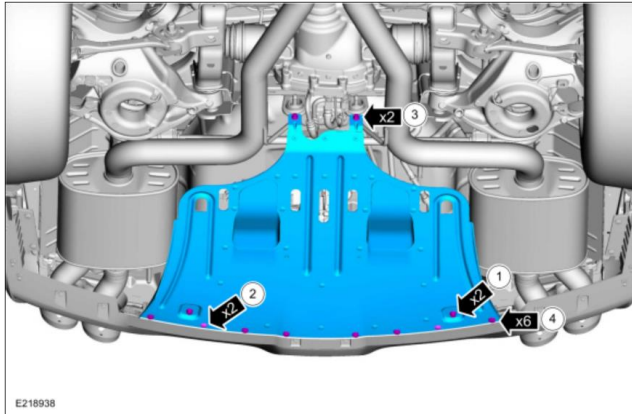

Remove cooling line retaining clip, be careful not to lose or damage.

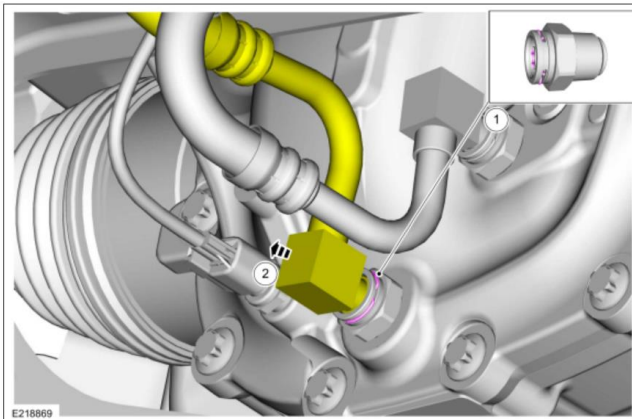

Remove cooling line and set aside. Remove cooling line fitting, save for installation.

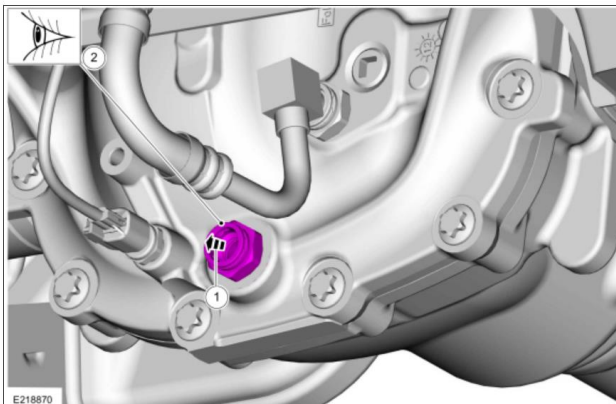

Ford Factory Shop Manual purchase options www.motorcraftservice.com

NO PART OF THIS DOCUMENT MAY BE REPRODUCED WITHOUT PRIOR AGREEMENT AND WRITTEN PERMISSION OF FORD PERFORMANCE PARTS © Ford Motor Company 2020

Muffler and Tailpipe Assembly Removal

Disconnect wire retainers and electrical connectors from assembly.

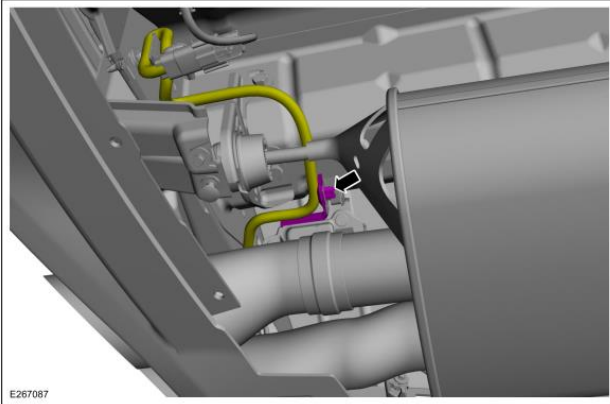

Loosen clamps and remove from muffler and tailpipe section.

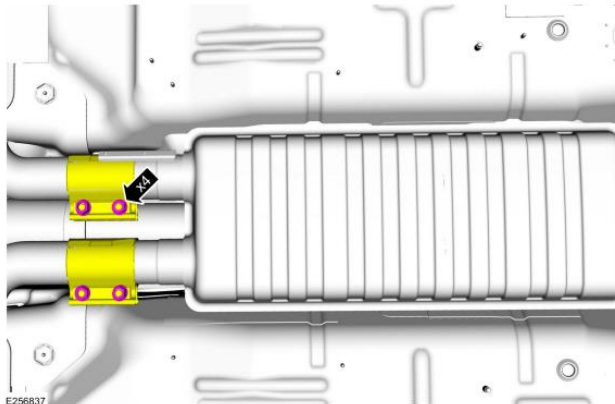

Remove system by removing front hanger bolts, save for installation and slide system forward. This step is at least a two-person job.

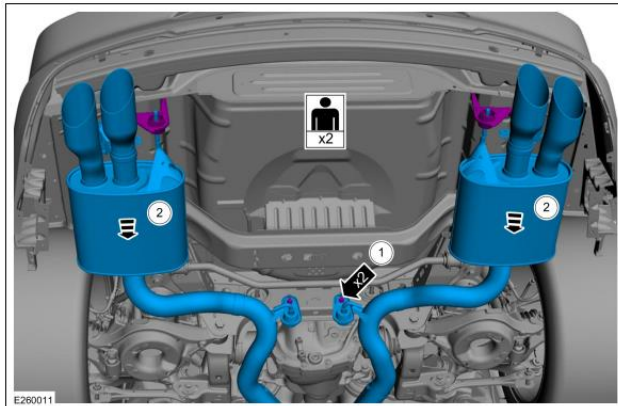

Ford Factory Shop Manual purchase options www.motorcraftservice.com

NO PART OF THIS DOCUMENT MAY BE REPRODUCED WITHOUT PRIOR AGREEMENT AND WRITTEN PERMISSION OF FORD PERFORMANCE PARTS © Ford Motor Company 2020

Driveshaft Removal

Index mark the driveshaft and pinion flange orientation for reference during installation.

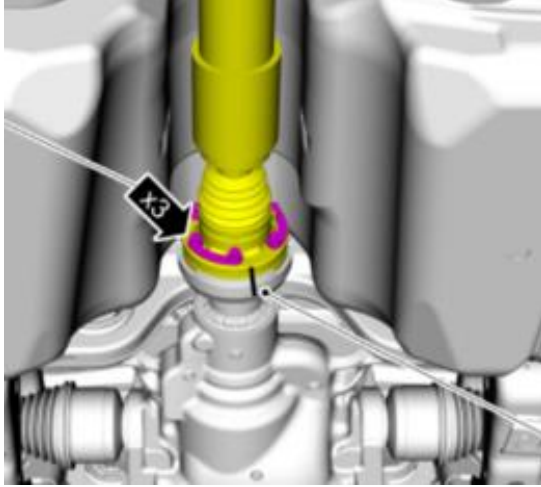

Note: Do not remove the driveshaft from the pinion flange by pulling on the driveshaft tube! It will damage the CV joint. Support the driveshaft with a ratchet strap or similar prior to separating the driveshaft from the pinion flange. Do not allow the driveshaft to hang freely, damage to the bearing assembly will occur.

Support the driveshaft with a ratchet strap or similar before removing hardware. Remove and save them for installation. Using a small pry bar, pry pinion flange and driveshaft apart.

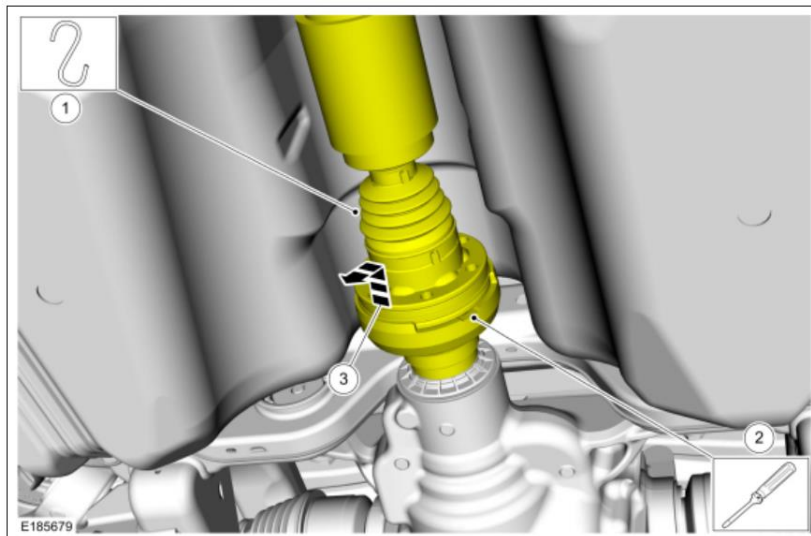

Ford Factory Shop Manual purchase options www.motorcraftservice.com

NO PART OF THIS DOCUMENT MAY BE REPRODUCED WITHOUT PRIOR AGREEMENT AND WRITTEN PERMISSION OF FORD PERFORMANCE PARTS © Ford Motor Company 2020

Halfshaft Removal

NOTICE: Never pick up or hold the halfshaft by only the inner or outer Constant Velocity (CV) joint. Damage to the CV joint will occur.

NOTICE: Never use a hammer to remove or install the halfshafts. Damage to the CV joint may occur.

NOTICE: Never use the halfshaft assembly as a lever to position other components. Damage to the halfshaft or CV joint may occur.

NOTICE: Do not allow the boots to contact sharp edges or hot exhaust components. Damage to the halfshaft boots will occur.

NOTICE: Do not drop assembled halfshafts. The impact may cut the boots from the inside without evidence of external damage.

Remove rear wheel and tire assemblies.

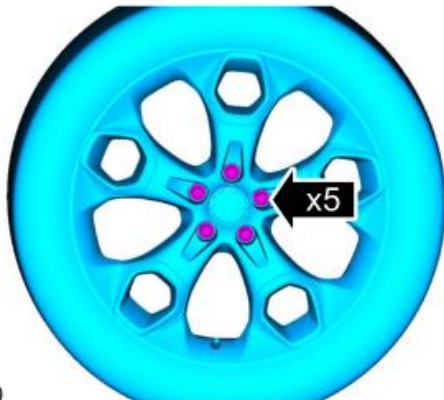

E145710

Note: Throughout this instruction you will find the “Trash Can” icon as seen in the below graphic. Ford Service Manuals recommend you replace the defined hardware. **In the case of “Torque to Yield” hardware you will find the hardware included in this kit.** All other cases, it is recommended that the hardware be replaced. If you choose not to replace it, please clean the hardware and mounting thread and reinstall with the use of locking compound. There is a complete hardware list on the last page of this instructions. All hardware is available at your local Ford and Lincoln Dealer.

Ford Factory Shop Manual purchase options www.motorcraftservice.com

NO PART OF THIS DOCUMENT MAY BE REPRODUCED WITHOUT PRIOR AGREEMENT AND WRITTEN PERMISSION OF FORD PERFORMANCE PARTS © Ford Motor Company 2020

Remove and discard halfshaft/spindle nuts.

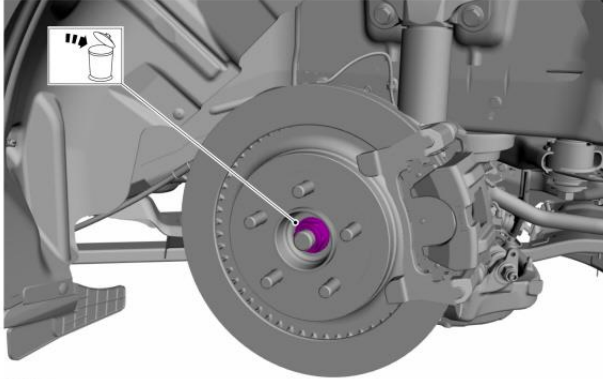

E261787

Press halfshaft from wheel hub. Apply parking brake if necessary.

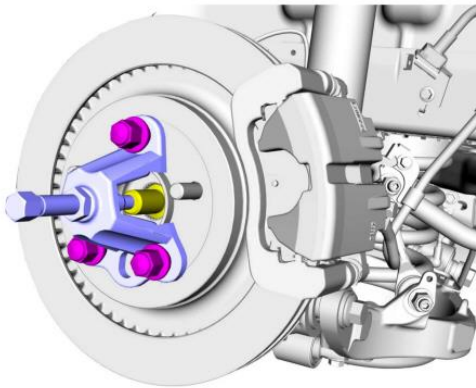

E187114

For GT350, remove parking brake cable from shoe actuation lever and bracket first.

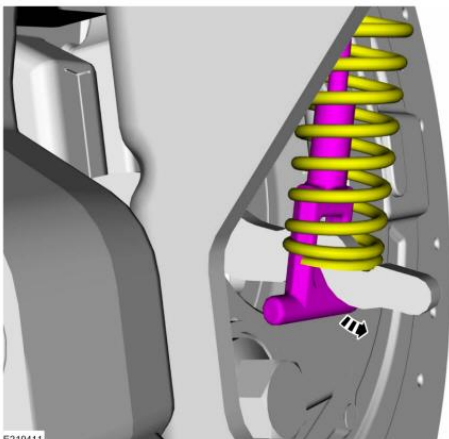

E219411

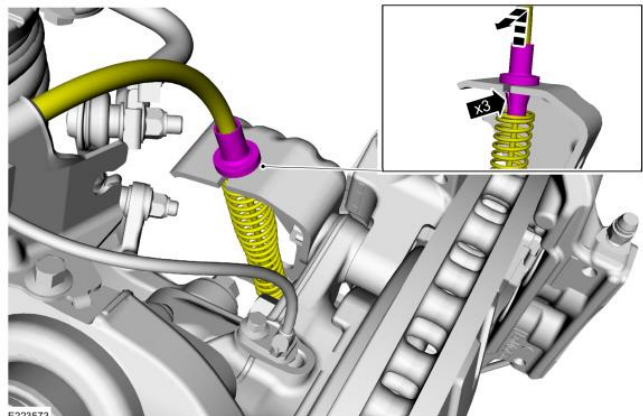

E223573

Ford Factory Shop Manual purchase options www.motorcraftservice.com

NO PART OF THIS DOCUMENT MAY BE REPRODUCED WITHOUT PRIOR AGREEMENT AND WRITTEN PERMISSION OF FORD PERFORMANCE PARTS © Ford Motor Company 2020

Remove Caliper mount bolts. Do not allow calipers to hang by brake lines, hang with S hook or twist ties.

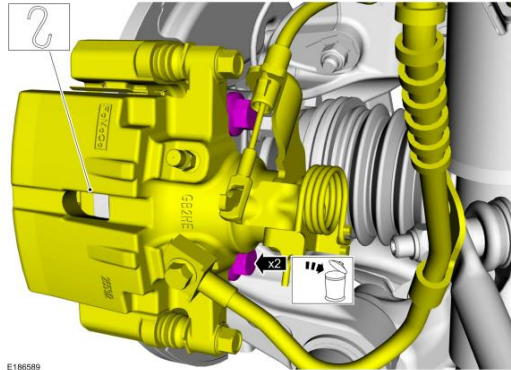

Remove Rotors.



Remove wheel bearing bolts and remove hubs assemblies.

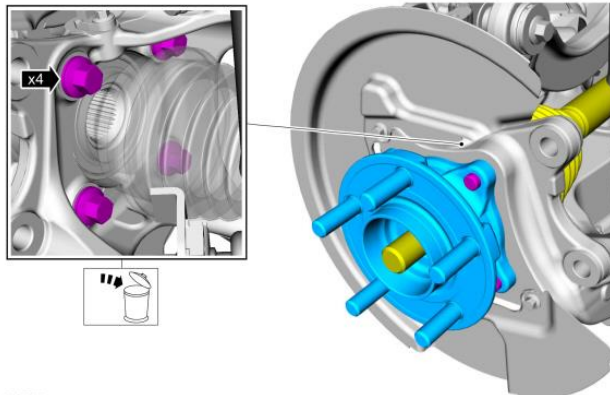

Ford Factory Shop Manual purchase options www.motorcraftservice.com

NO PART OF THIS DOCUMENT MAY BE REPRODUCED WITHOUT PRIOR AGREEMENT AND WRITTEN PERMISSION OF FORD PERFORMANCE PARTS © Ford Motor Company 2020

Remove wheel speed sensor bolt and sensor, position it aside to avoid damaging it. Also, remove parking brake bracket bolt and position it aside.

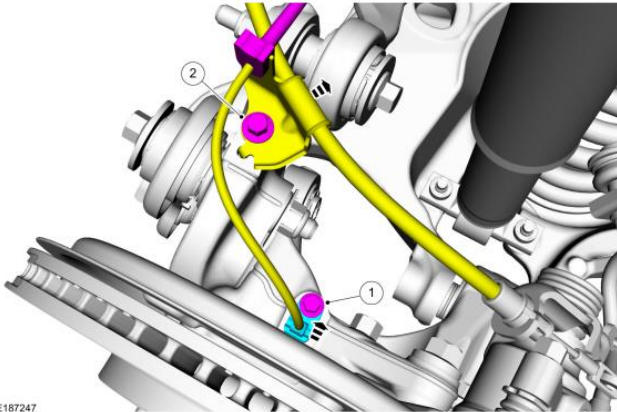

E187247

Support suspension at curb height.

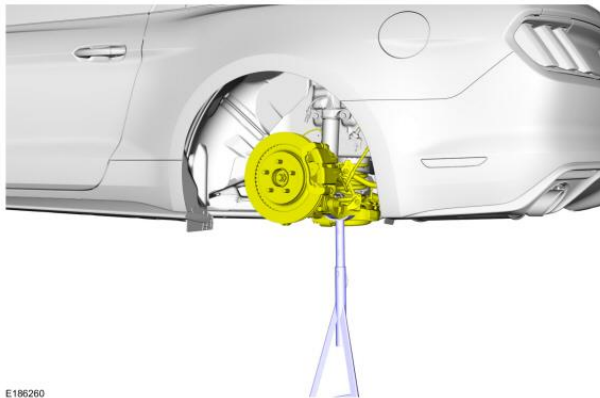

E186260

Remove the lower arm vertical link.

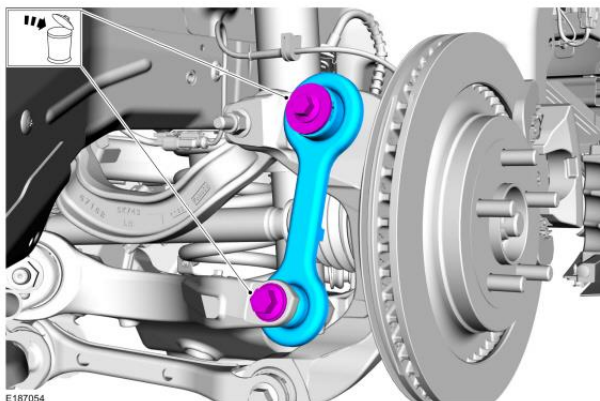

E187054

Ford Factory Shop Manual purchase options www.motorcraftservice.com

NO PART OF THIS DOCUMENT MAY BE REPRODUCED WITHOUT PRIOR AGREEMENT AND WRITTEN PERMISSION OF FORD PERFORMANCE PARTS © Ford Motor Company 2020

Support halfshaft then remove the knuckle to upper arm nut and bolt, knuckle to toe link nut and bolt and knuckle to lower arm bolt. Remove knuckle.

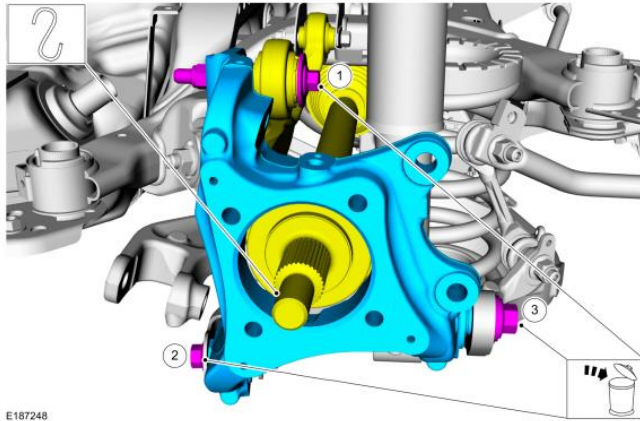

E187248

Using a pry bar, remove halfshafts. Replace halfshaft seal and circlip if damaged. If there is any question to their condition, replace them.

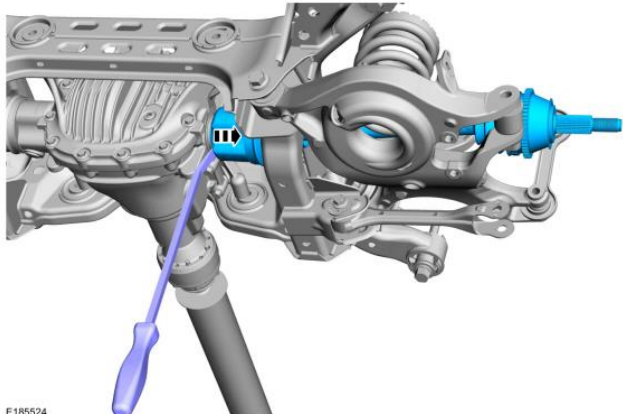

E185524

If equipped, disconnect differential temperature sensor

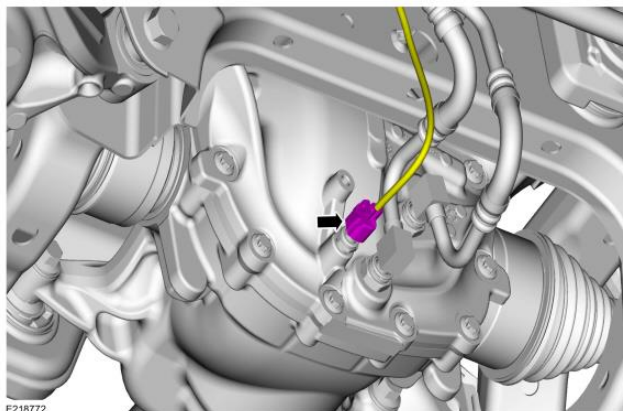

E218772

NO PART OF THIS DOCUMENT MAY BE REPRODUCED WITHOUT PRIOR AGREEMENT AND WRITTEN PERMISSION OF FORD PERFORMANCE PARTS © Ford Motor Company 2020

If equipped, remove differential cooling line clip, be careful not to lose or damage. Remove differential line and set aside. Remove fitting for use during installation.

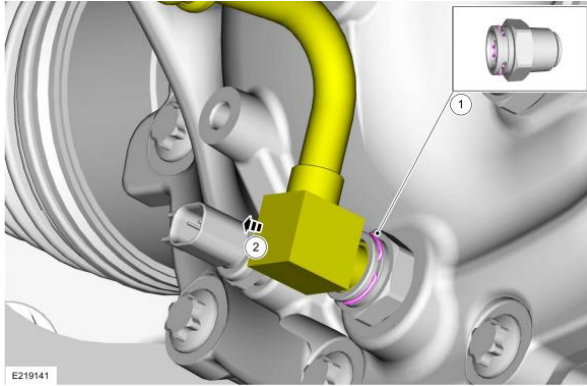

Disconnect differential vent tube from housing.

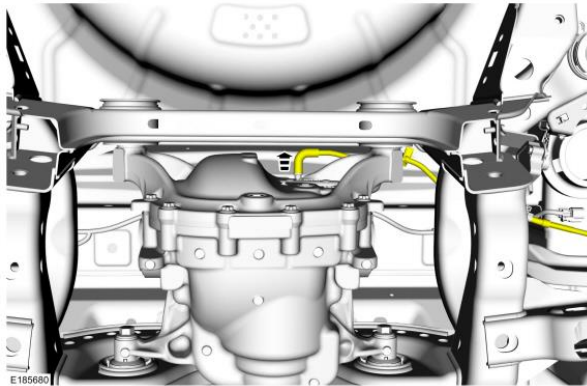

Note: The differential is very heavy, and it will require a transmission jack to support it before fasteners are removed.

Remove front and rear differential bolts. Remove differential.

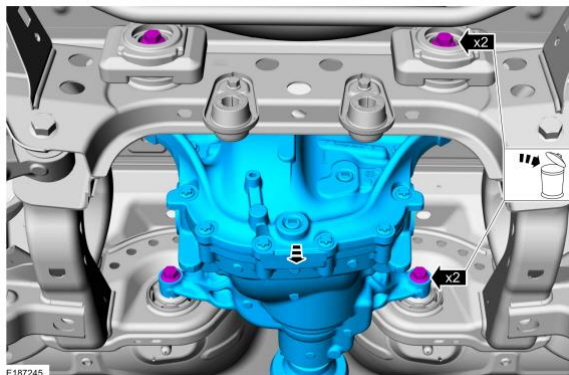

Ford Factory Shop Manual purchase options www.motorcraftservice.com

NO PART OF THIS DOCUMENT MAY BE REPRODUCED WITHOUT PRIOR AGREEMENT AND WRITTEN PERMISSION OF FORD PERFORMANCE PARTS © Ford Motor Company 2020

Differential Cover Removal

Note: The differential cover bolts are low profile external torx. Use an EPL16 socket to remove bolts.

Remove differential cover bolts and differential cover. Be careful not to damage housing flange surface.

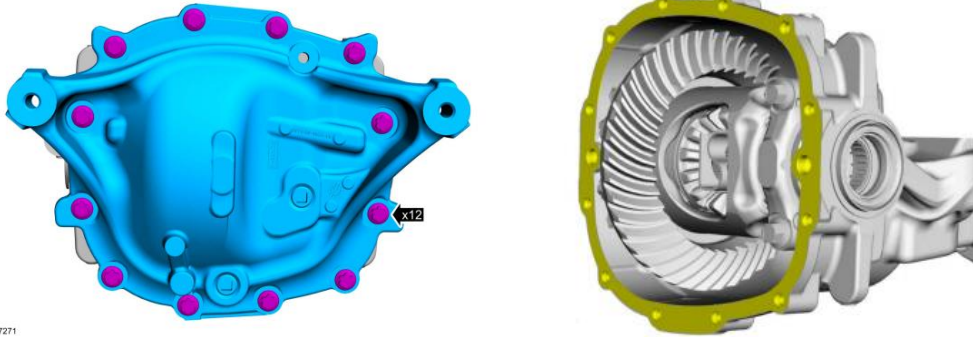

Differential Housing Flange Cleaning

Note: Don't use any metal cleaning tools or power sand or grinding tools to clean the housing flange surface. These tools cause scratches and gouges which create leak paths.

Note: The use of latex gloves is recommended. Using gloves will minimize the risk of contaminating the sealant during assembly.

Note: Place clean, lint-free towels over differential cavity. When housing flange is clean, carefully remove towels from cavity making sure no foreign material drops into the housing.

Remove loose sealant by hand or with a plastic scraper or plastic razor blade.

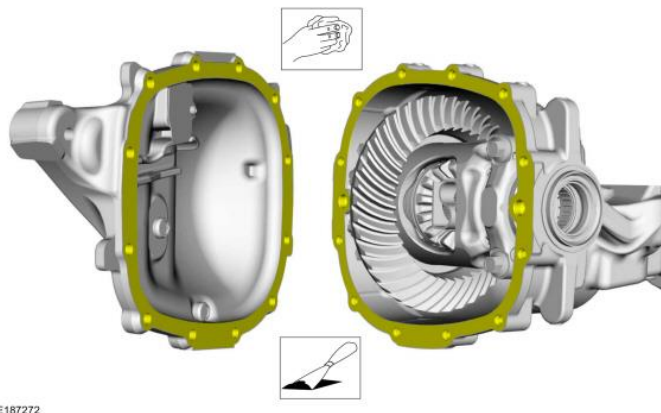

NO PART OF THIS DOCUMENT MAY BE REPRODUCED WITHOUT PRIOR AGREEMENT AND WRITTEN PERMISSION OF FORD PERFORMANCE PARTS © Ford Motor Company 2020

Apply gasket remover to housing flange surface. Allow gasket remover to work for several minutes. Use lint-free towel and plastic scraper or plastic razor blade to remove any remaining sealant. Repeat the process as needed until surface is clean.



Differential Housing and Ford Performance Cover Assembly

Note: Check all internal components for signs of defects, repair or replace at this time.

Note: Use thread sealer on all tapered pipe threads.

Before installing the Ford Performance Cover on the differential housing, make sure the load bolts are backed out sufficiently, so they do not contact the bearing caps.



NO PART OF THIS DOCUMENT MAY BE REPRODUCED WITHOUT PRIOR AGREEMENT AND WRITTEN PERMISSION OF FORD PERFORMANCE PARTS © Ford Motor Company 2020

Clean differential housing flange surface and Ford Performance Cover flange with a lint-free towel soaked in isopropyl alcohol (90% minimum).



Note: The use of latex gloves is recommended. Using gloves will minimize the risk of contaminating the sealant during assembly.

Prepare both flange surfaces with metal surface prep wipes. Allow to dry before applying silicone gasket and sealant.

Note: be careful not to apply excessive silicone gasket and sealant, it may cause differential cooling system to function poorly or fail.

Following the silicone gasket and sealant instructions, fill the groove in the cover and then apply a 2mm bead as shown.

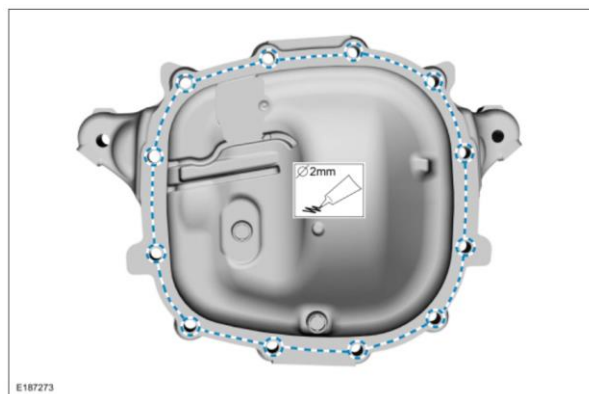

Install cover with original bolts. Torque to 34 lb. ft (46 Nm).

Ford Factory Shop Manual purchase options www.motorcraftservice.com

NO PART OF THIS DOCUMENT MAY BE REPRODUCED WITHOUT PRIOR AGREEMENT AND WRITTEN PERMISSION OF FORD PERFORMANCE PARTS © Ford Motor Company 2020

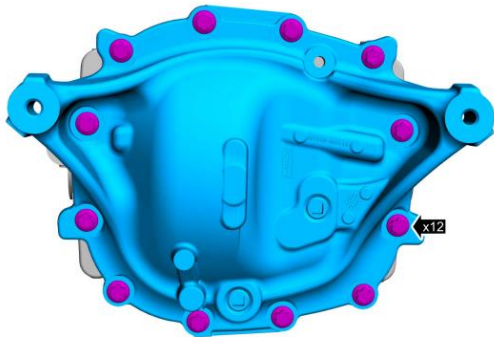

E187271

Carefully tighten the two load bolts until they contact the bearing caps. Torque load bolts to 5-10 lb. ft (7-13 Nm) Excessive torque can damage the differential bearings! Torque jam nuts to 25-30 lb. ft (34-40 Nm).



Differential Housing Installation

Using a transmission jack, install differential with Ford Performance Cover. Torque forward bolts first, rearward bolts second. Torque to 129 lb. ft (175 Nm).

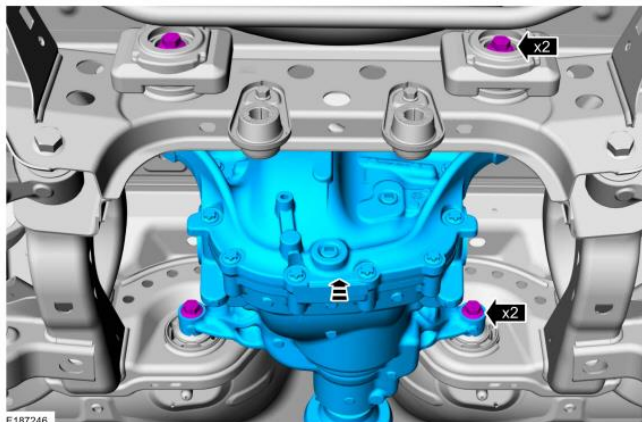

E187246

Ford Factory Shop Manual purchase options www.motorcraftservice.com

NO PART OF THIS DOCUMENT MAY BE REPRODUCED WITHOUT PRIOR AGREEMENT AND WRITTEN PERMISSION OF FORD PERFORMANCE PARTS © Ford Motor Company 2020

Connect vent tube.

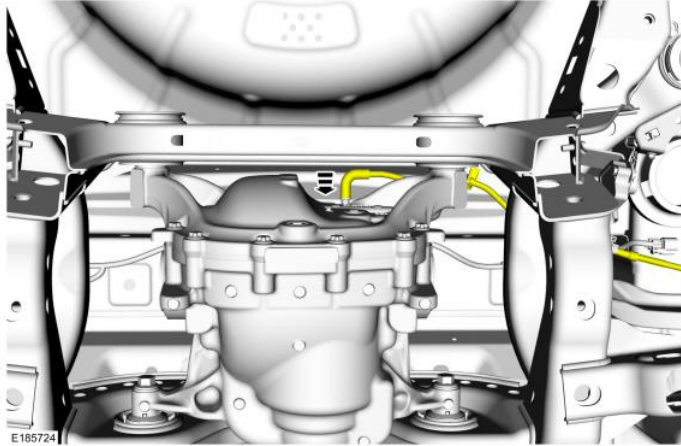

If equipped, Install differential cooling line fittings. Torque to 17 lb. ft (23 Nm).

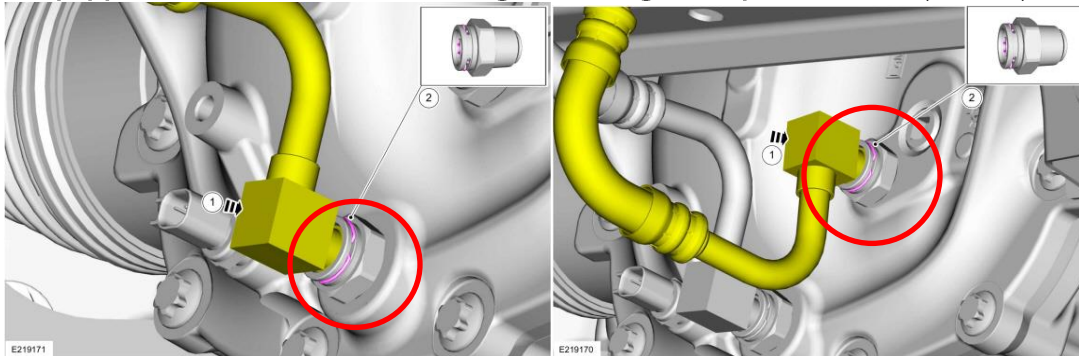

Install differential cooler lines and retaining lips.

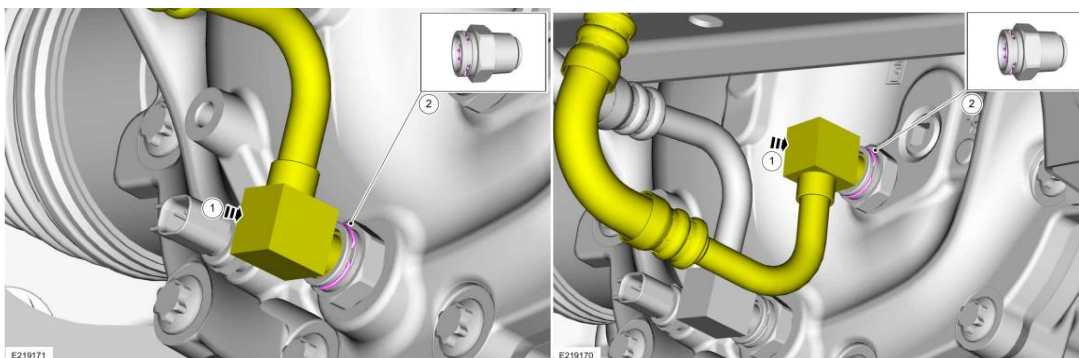

Ford Factory Shop Manual purchase options www.motorcraftservice.com

NO PART OF THIS DOCUMENT MAY BE REPRODUCED WITHOUT PRIOR AGREEMENT AND WRITTEN PERMISSION OF FORD PERFORMANCE PARTS © Ford Motor Company 2020

If equipped, Install differential temperature sensor and electrical connector. Torque to 89 lb.in (10 Nm).

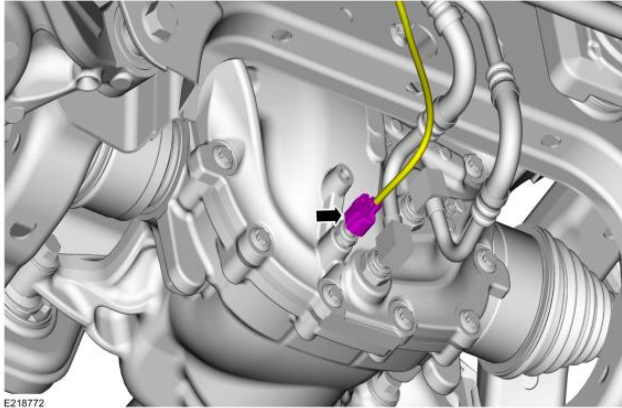

Driveshaft Installation

Position the driveshaft to the pinion flange, align the index mark made during disassembly.

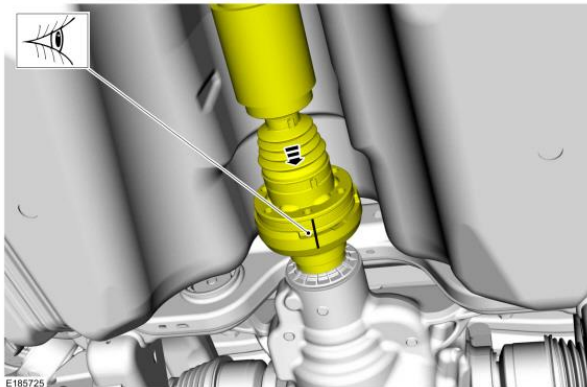

Make sure the driveshaft flange is fully seated prior to installing the bolts. For Mustang Torque to 41 lb. ft (55 Nm), for GT350 Torque to 46 lb. ft (63 Nm). Reminder, add locking compound to these bolts.

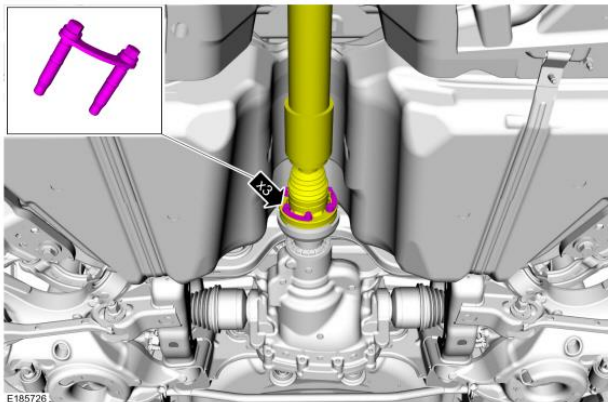

Ford Factory Shop Manual purchase options www.motorcraftservice.com

NO PART OF THIS DOCUMENT MAY BE REPRODUCED WITHOUT PRIOR AGREEMENT AND WRITTEN PERMISSION OF
FORD PERFORMANCE PARTS © Ford Motor Company 2020

Halfshaft Installation

NOTICE: Never pick up or hold the halfshaft by only the inner or outer Constant Velocity (CV) joint. Damage to the CV joint will occur.

NOTICE: Never use a hammer to remove or install the halfshafts. Damage to the CV joint may occur.

NOTICE: Never use the halfshaft assembly as a lever to position other components. Damage to the halfshaft or CV joint may occur.

NOTICE: Do not allow the boots to contact sharp edges or hot exhaust components. Damage to the halfshaft boots will occur.

NOTICE: Do not drop assembled halfshafts. The impact may cut the boots from the inside without evidence of external damage.

Note: When install halfshafts, do not let the splines contact the housing seals. Damage to the seals may occur.

Install halfshafts until the circlip is fully seated.

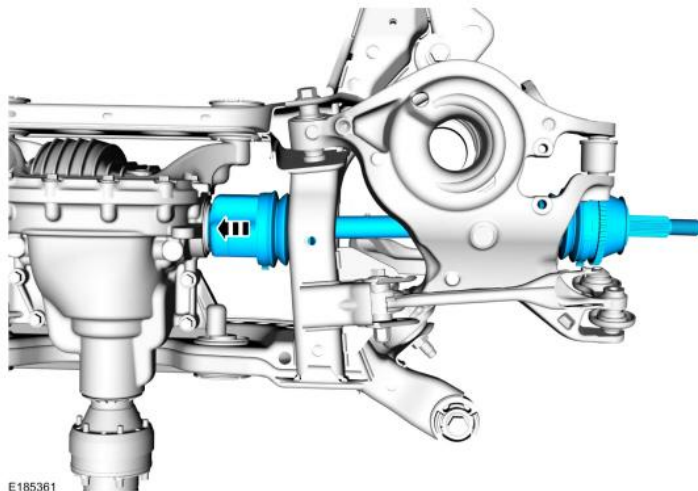

NO PART OF THIS DOCUMENT MAY BE REPRODUCED WITHOUT PRIOR AGREEMENT AND WRITTEN PERMISSION OF FORD PERFORMANCE PARTS © Ford Motor Company 2020

Install knuckle, do not torque the hardware at this point. Chassis must be loaded at ride height for torqueing. Torque knuckle to lower arm 203 lb.ft (275 Nm), knuckle to toe link 129 lb.ft (175 Nm) and knuckle to upper arm 76 lb.ft (103 Nm). Reminder, add locking compound to these joints.

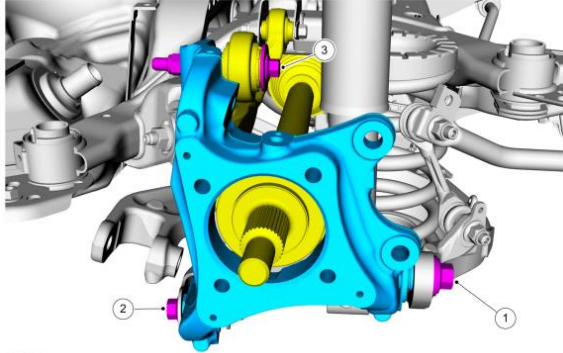

E187249

Install parking brake bracket and wheel speed sensor. Torque parking brake bracket bolt to 21 lb.ft (28 Nm) and wheel speed sensor bracket to 80 lb.in (9 Nm).

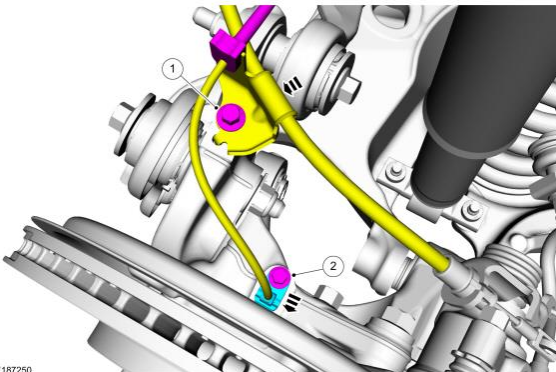

E187250

Install vertical link, do not torque the hardware at this point. Chassis must be loaded at ride height for torqueing. Torque vertical link upper bolt 76 lb.ft (103 Nm) and the lower bolt 129 lb.ft (175 Nm). Reminder, add locking compound to these joints.

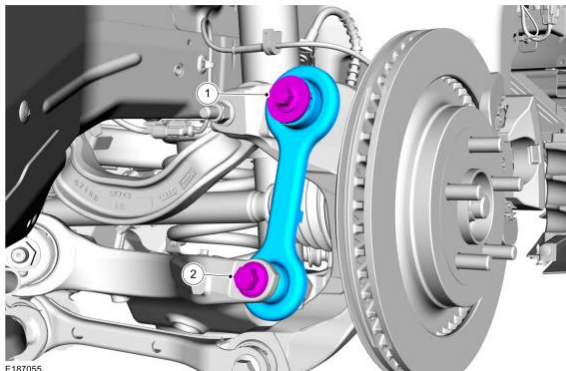

E187055

NO PART OF THIS DOCUMENT MAY BE REPRODUCED WITHOUT PRIOR AGREEMENT AND WRITTEN PERMISSION OF FORD PERFORMANCE PARTS © Ford Motor Company 2020

Install hub assembly, tighten in a cross pattern. Torque to 98 lb.ft (133 Nm).

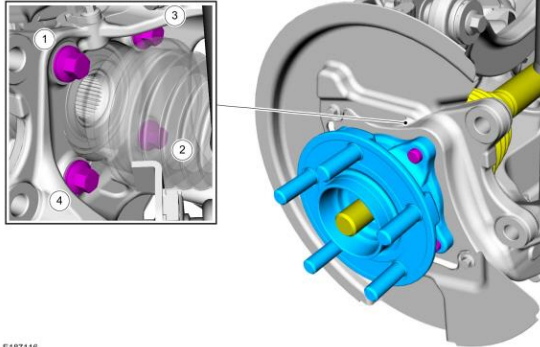

E187116

Install brake rotor.

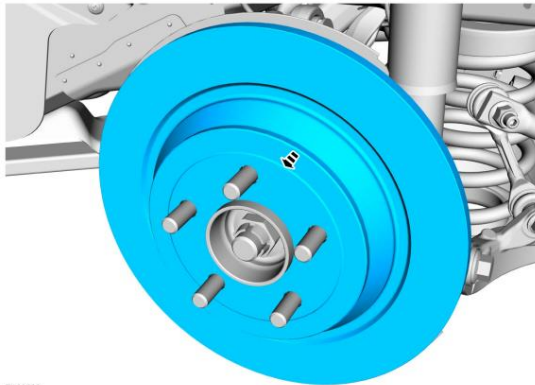

E186590

Install brake caliper and bracket assembly. For Mustang Torque to 129 lb. ft (175Nm), for GT350 torque to 81 lb. ft (110 Nm).

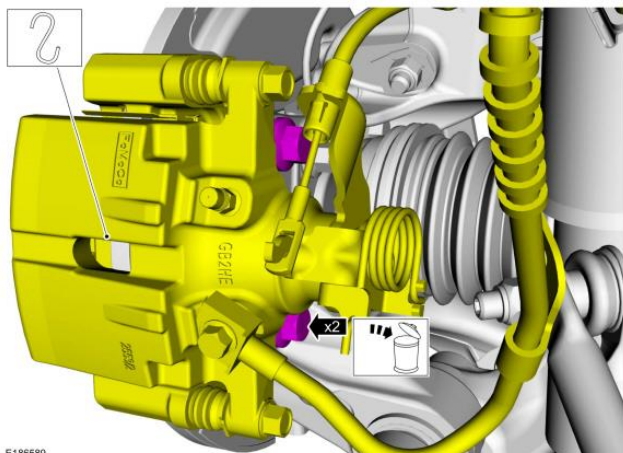

E186589

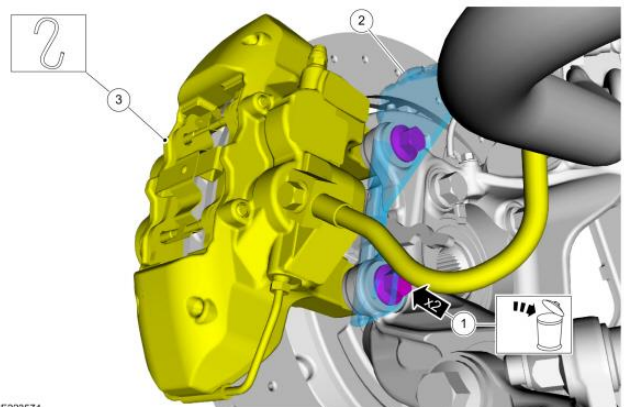

E223574

Ford Factory Shop Manual purchase options www.motorcraftservice.com

NO PART OF THIS DOCUMENT MAY BE REPRODUCED WITHOUT PRIOR AGREEMENT AND WRITTEN PERMISSION OF FORD PERFORMANCE PARTS © Ford Motor Company 2020

For GT350, install parking brake cable in bracket and then into the brake shoe actuation lever.

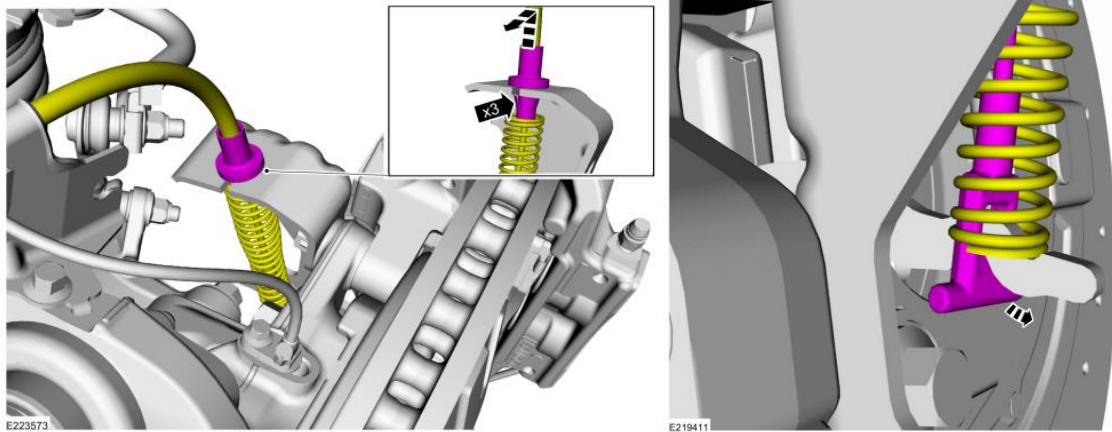

Install new hub nut. Torque in two steps, first to 85 lb.ft (115 Nm), then plus 30°. Apply parking brake to keep the system from moving while torqueing.

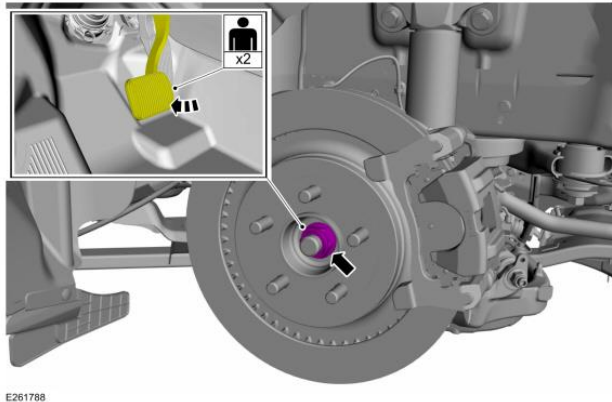

Muffler and Tailpipe Assembly Installation

Install muffler and tailpipe section by sliding system into the rear isolators. This step is at least a two-person job. Install hangers, torque to 18 lb.ft (25 Nm).

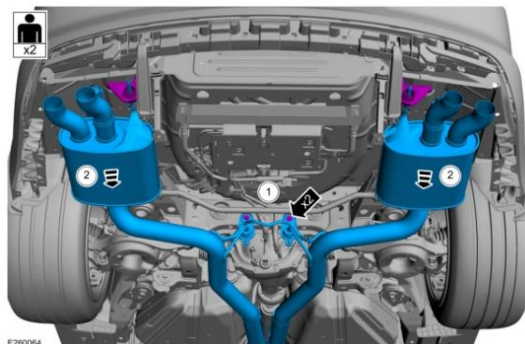

Ford Factory Shop Manual purchase options www.motorcraftservice.com

NO PART OF THIS DOCUMENT MAY BE REPRODUCED WITHOUT PRIOR AGREEMENT AND WRITTEN PERMISSION OF FORD PERFORMANCE PARTS © Ford Motor Company 2020

Line up the front and rear sections and Install clamps. Torque to 35 lb.ft (48 Nm).

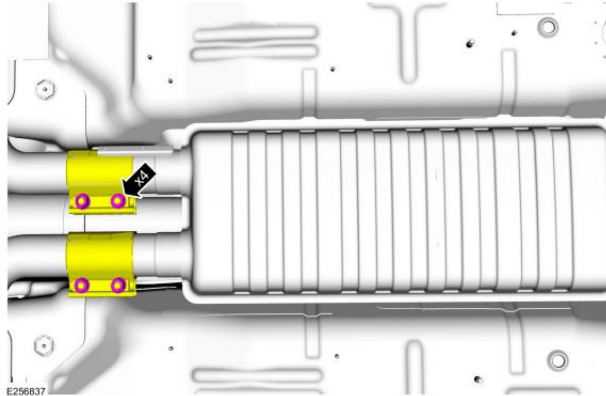

Reconnect wire retainers and electrical connectors from assembly.

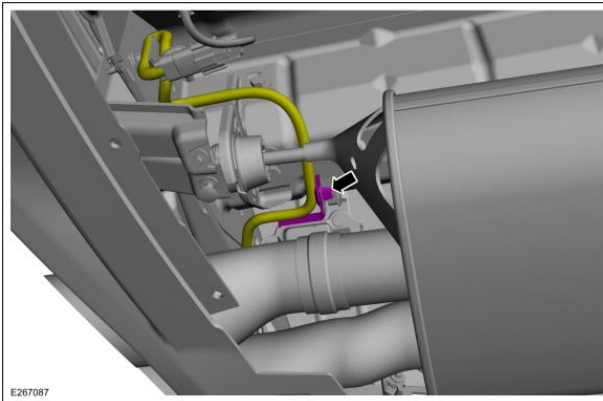

Fluid Fill

Fill system to within 9 mm (.35 in) of the fill plug. When filling system, start with the friction modifier first and finish with the gear lube. If system is equipped with fluid cooler, it is recommended that the system is cycled with a diagnostic tool to prime the system, then topped off to the fill level. Torque the plug to 25 lb. ft (34 Nm).

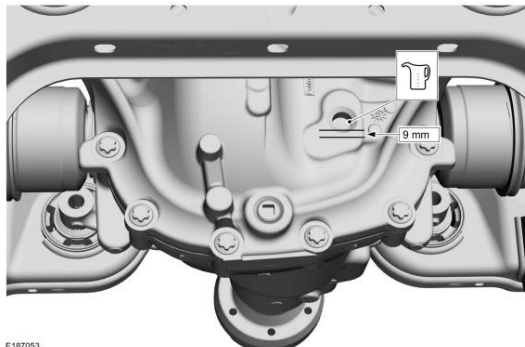

Ford Factory Shop Manual purchase options www.motorcraftservice.com

NO PART OF THIS DOCUMENT MAY BE REPRODUCED WITHOUT PRIOR AGREEMENT AND WRITTEN PERMISSION OF FORD PERFORMANCE PARTS © Ford Motor Company 2020

If Equipped, Deflector Install

Install deflector, torque front deflector bolts to 22 lb. ft (30 Nm) and rear deflector bolts 80 lb.in (9 Nm).

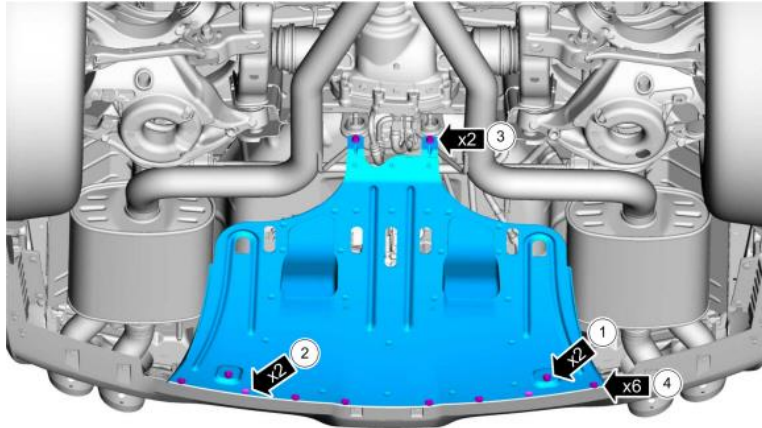

E218938

Rear Wheels Installation

Install rear wheels. Torque to 150 lb.ft (204 Nm) in the pattern defined below. Re-torque after 100 miles (160 km).

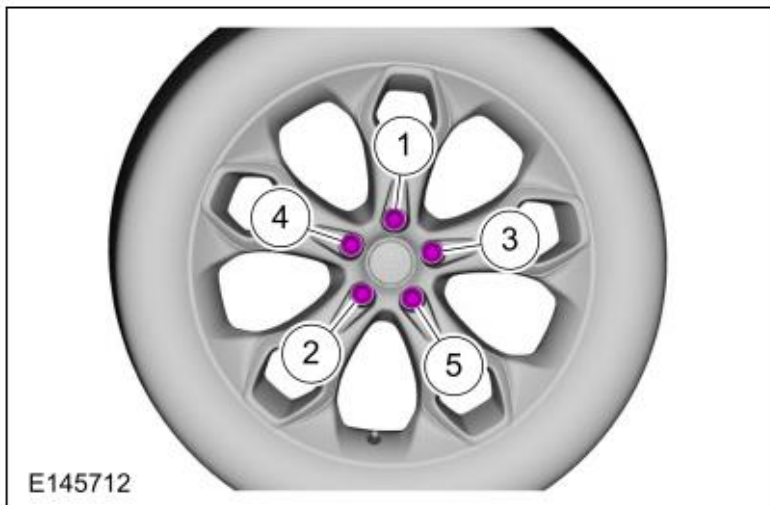

Ford Factory Shop Manual purchase options www.motorcraftservice.com



M-4033-G4
Mustang GT / GT350
8.8" IRS Axle Girdle Cover

NO PART OF THIS DOCUMENT MAY BE REPRODUCED WITHOUT PRIOR AGREEMENT AND WRITTEN PERMISSION OF FORD PERFORMANCE PARTS © Ford Motor Company 2020

Alignment

Complete vehicle alignment and torque chassis hardware.

Torque knuckle to lower arm 203 lb. ft (275 Nm), knuckle to toe link 129 lb. ft (175 Nm) and knuckle to upper arm 76 lb. ft (103 Nm).

Torque vertical link upper bolt 76 lb. ft (103 Nm) and the lower bolt 129 lb. ft (175 Nm).

Alignment Specifications

NOTE: Measurements listed at curb load. Curb load is defined as "full service fluids, full fuel tank(s), no passengers and no cargo".

Item	LH	RH	Total/Split
Front			
Camber — (Base Coupe, Base Convertible, Performance Package Convertible, Track Package Convertible)	-0.72° ± 0.75°	-0.72° ± 0.75°	0.0° ± 0.75°
Camber — (Performance Package Coupe, Track Package Coupe)	-1.03° ± 0.75°	-1.03° ± 0.75°	0.0° ± 0.75°
Camber — (V8 - Performance Package Level 2)	-1.21° ± 0.75°	-1.21° ± 0.75°	0.0° ± 0.75°
Camber — (GT350)	-1.03° ± 0.75°	-1.03° ± 0.75°	0.0° ± 0.75°
Camber — (GT350R)	-1.19° ± 0.75°	-1.19° ± 0.75°	0.0° ± 0.75°
Camber — (GT500)	-0.92° ± 0.75°	-0.92° ± 0.75°	0.0° ± 0.75°
Camber — (GT500 Track)	-1.06° ± 0.75°	-1.06° ± 0.75°	0.0° ± 0.75°
Caster — (Base Coupe, Base Convertible, Performance Package Convertible, Track Package Convertible)	7.12° ± 0.75°	7.12° ± 0.75°	0.0° ± 0.75°
Caster — (Performance Package Coupe, Track Package Coupe)	6.91° ± 0.75°	6.91° ± 0.75°	0.0° ± 0.75°
Caster — (V8 - Performance Package Level 2)	7.11° ± 0.75°	7.11° ± 0.75°	0.0° ± 0.75°
Caster — (GT350)	6.83° ± 0.75°	6.83° ± 0.75°	0.0° ± 0.75°
Caster — (GT350R)	7.75° ± 0.75°	7.75° ± 0.75°	0.0° ± 0.75°
Caster — (GT500)	7.81° ± 0.75°	7.81° ± 0.75°	0.0° ± 0.75°

Ford Factory Shop Manual purchase options www.motorcraftservice.com



M-4033-G4
Mustang GT / GT350
8.8" IRS Axle Girdle Cover

NO PART OF THIS DOCUMENT MAY BE REPRODUCED WITHOUT PRIOR AGREEMENT AND WRITTEN PERMISSION OF
FORD PERFORMANCE PARTS © Ford Motor Company 2020

Item	LH	RH	Total/Split
Caster — (GT500 Track)	8.08° ± 0.75°	8.08° ± 0.75°	0.0° ± 0.75°
Toe — (All Models Except, GT350, GT350R, V8 - Performance Package Level 2)	—	—	0.0° ± 0.20°
Toe — (V8 - Performance Package Level 2)	—	—	0.10° ± 0.20°
Toe — (GT350, GT350R)	—	—	-0.10° ± 0.20°
Toe — (GT500, GT500 Track)	—	—	-0.10° ± 0.20°
Rear			
Camber — (All Models Except, GT350, GT350R, V8 - Performance Package Level 2)	-1.50° ± 0.75°	-1.50° ± 0.75°	—
Camber — (V8 - Performance Package Level 2)	-1.14° ± 0.75°	-1.14° ± 0.75°	—
Camber — (GT350)	-1.20° ± 0.75°	-1.20° ± 0.75°	—
Camber — (GT350R)	-1.20° ± 0.75°	-1.20° ± 0.75°	—
Camber — (GT500)	-1.70° ± 0.75°	-1.70° ± 0.75°	—
Camber — (GT500 Track)	-1.70° ± 0.75°	-1.70° ± 0.75°	—
Toe — (All Models Except, GT350, GT350R, V8 - Performance Package Level 2)	0.12° ± 0.20°	0.12° ± 0.20°	0.23° ± 0.20°
Toe — (V8 - Performance Package Level 2)	0.15° ± 0.20°	0.15° ± 0.20°	0.30° ± 0.20°
Toe — (GT350, GT350R)	0.15° ± 0.20°	0.15° ± 0.20°	0.30° ± 0.30°
Toe — (GT500, GT500 Track)	0.15° ± 0.20°	0.15° ± 0.20°	0.30° ± 0.30°

Ford Factory Shop Manual purchase options www.motorcraftservice.com



M-4033-G4
Mustang GT / GT350
8.8" IRS Axle Girdle Cover

NO PART OF THIS DOCUMENT MAY BE REPRODUCED WITHOUT PRIOR AGREEMENT AND WRITTEN PERMISSION OF FORD PERFORMANCE PARTS © Ford Motor Company 2020

Ride Height

NOTE: Measurements listed at curb load. Curb load is defined as "full service fluids, full fuel tank(s), no passengers and no cargo".

Item	Specification
Front Ride Height	
All Models — (Except, GT350, GT350R)	48.8 mm (1.921 in) ± 12 mm (0.472 in)
GT350	35.2 mm (1.386 in) ± 12 mm (0.472 in)
GT350R	43.1 mm (1.696 in) ± 12 mm (0.472 in)
GT500	47.6 mm (1.874 in) ± 12 mm (0.472 in)
GT500 Track	37.4 mm (1.472 in) ± 12 mm (0.472 in)
Rear Ride Height	
All Models — (Except, GT350, GT350R)	32.1 mm (1.264) ± 10 mm (0.394 in)
GT350	27.4 mm (1.078) ± 10 mm (0.394 in)
GT350R	18.9 mm (0.744) ± 10 mm (0.394 in)
GT500	30.5 mm (1.200) ± 10 mm (0.394 in)
GT500 Track	17.4 mm (0.685) ± 10 mm (0.394 in)

Vehicle Lean Side-To-Side Differences

Front — Maximum	7.5 mm (0.295 in)
Rear — Maximum	6.3 mm (0.248 in)

General Specifications

Item	Specification
Thrust Angle — Rear	
All Models	0.0° ± 0.5°

Ford Factory Shop Manual purchase options www.motorcraftservice.com

NO PART OF THIS DOCUMENT MAY BE REPRODUCED WITHOUT PRIOR AGREEMENT AND WRITTEN PERMISSION OF FORD PERFORMANCE PARTS © Ford Motor Company 2020

Ride Height Measurement — Front

1. **NOTE:** Make sure that the vehicle is positioned on a flat, level surface and the tires are inflated to the correct pressure. Vehicle should have a full tank of fuel.
 1. Ride height = 3-2
 2. Measure the distance between the flat level surface and the center of the rear control arm ball joint cap (measurement 2)
 3. Measure the distance between the flat level surface and the center of the rear control arm inboard bolt (measurement 3)
- Use the General Equipment: Surface Gauge

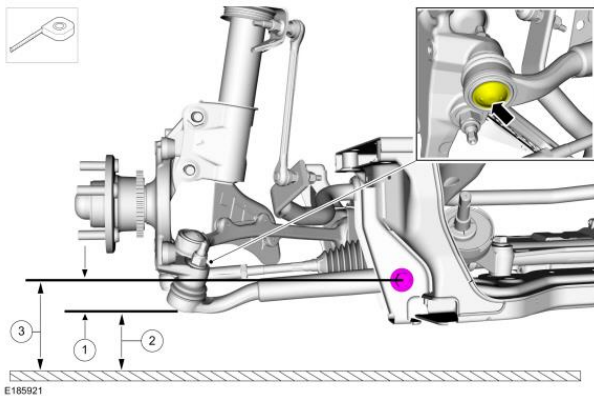

With the surface gauge positioned on a flat, level surface, record the measurement of the surface gauge position (measurement 2) and (measurement 3).

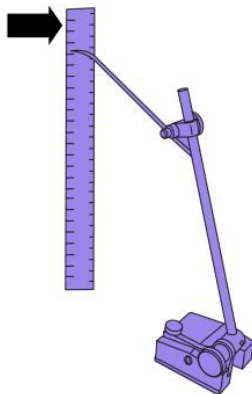

3. Subtract measurement 2 from measurement 3 to obtain the front ride height.

NO PART OF THIS DOCUMENT MAY BE REPRODUCED WITHOUT PRIOR AGREEMENT AND WRITTEN PERMISSION OF FORD PERFORMANCE PARTS © Ford Motor Company 2020

Ride Height Measurement — Rear

4.
 1. Ride height = 2-3
 2. Measurement 2
 3. Measurement 3
Use the General Equipment: Surface Gauge

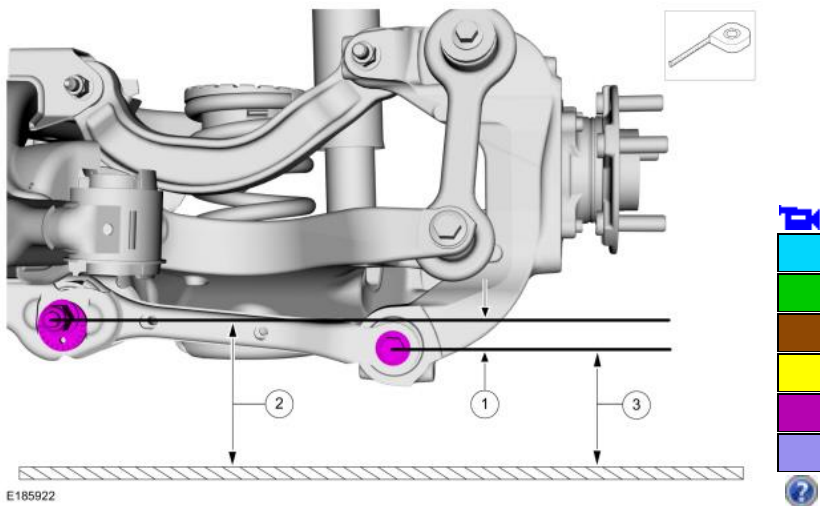

5. Measure the distance between the flat level surface and the center of the toe link inboard cam bolt (measurement 2).
6. Measure the distance between the flat level surface and the center of the toe link outboard bolt (measurement 3).
7. Subtract measurement 3 from measurement 2 to obtain the rear ride height.



M-4033-G4
Mustang GT / GT350
8.8" IRS Axle Girdle Cover

NO PART OF THIS DOCUMENT MAY BE REPRODUCED WITHOUT PRIOR AGREEMENT AND WRITTEN PERMISSION OF
FORD PERFORMANCE PARTS © Ford Motor Company 2020

Ford Service Parts Hardware List

Part Number	Description	Quantity
FR3Z-4B496-B	Driveshaft Bolt, M10 w/Washer	3
W715623-S439	Caliper Bracket Mounting Bolt, M14 x 46.5	4
W718188-S439	Hub Bolt, M12 x 55	8
W716342-S439	Vertical Link Lower Bolt, M14 x 82	2
W716795-S439	Vertical Link Upper Bolt, M12 x 104	2
W715682-S900	Vertical Link Upper Nut, M12	2
W716795-S439	Upper Arm to Knuckle Bolt, M12 x 104	2
W520214-S440	Upper Arm to Knuckle Nut, M12	2
W715779-S439	Toe Link to Knuckle, M14 x 72	2
W716341-S439	Lower Arm to Knuckle, M16 x 118	2
W716979-S439	Differential to Subframe, Rear, M14 x 90 Auto	2
W717748-S439	Differential to Subframe, Rear, M14 x 130 MT82	2
W716983-S439	Differential to Subframe, Front, M14 x 75	2
CCPZ-3B477-F	Hub Nut, M22 x 1.5	2
FR3Z-4B422-A	Inner Half Shaft Clip	2
AL3Z-4B416-A	Differential Housing Axle Seal	2
DR3Z-6K741-A	Fitting, Oil Cooler line to Housing	2
5R3Z-7860108-AA	Plug, 1/2" -14 NPT Magnetic	2

Ford Factory Shop Manual purchase options www.motorcraftservice.com