



FORD PERFORMANCE

M-5230-M2EB/EC/EBV/ECV/SB/SC/SBV/SCV/TBV/TCV

Model 2024+

Mustang 2.3L rear section exhaust

NO PART OF THIS DOCUMENT MAY BE REPRODUCED WITHOUT PRIOR AGREEMENT AND WRITTEN PERMISSION OF
FORD PERFORMANCE PARTS © Ford Motor Company 2020

PRIOR TO INSTALLATION READ THESE INSTRUCTION COMPETELY
For questions, Call the FORD PERFORMANCE Techline 1-800-367-3788

Please visit <https://www.performanceparts.ford.com> for warranty information

OVERVIEW:

The use of a floor hoist is recommended for this installation. If you do not have access to one, use a hydraulic floor jack and jack stands to raise the vehicle.

!! CAUTION: JACK STANDS MUST BE USED ON A LEVEL SURFACE AND BE SECURELY SEATED. FAILURE TO DO SO MAY RESULT IN PERSONAL INJURY OR VEHICLE DAMAGE !!

Bill of Materials

1. OEM Quad-Tip rear valence



Factory Ford shop manuals are available from Helm Publications, 1-800-782-4356



FORD PERFORMANCE

M-5230-M2EB/EC/EBV/ECV/SB/SC/SBV/SCV/TBV/TCV

Model 2024+

Mustang 2.3L rear section exhaust

Removal - All Vehicles

NOTE: Removal steps in this procedure may contain installation details.

1. Remove the rear wheels and tires.
Refer to: Wheel and Tire (204-04A Wheels and Tires, Removal and Installation).
2. Remove the screws, the bolts and the push pins.
Torque: 18 lb.in (2 Nm)

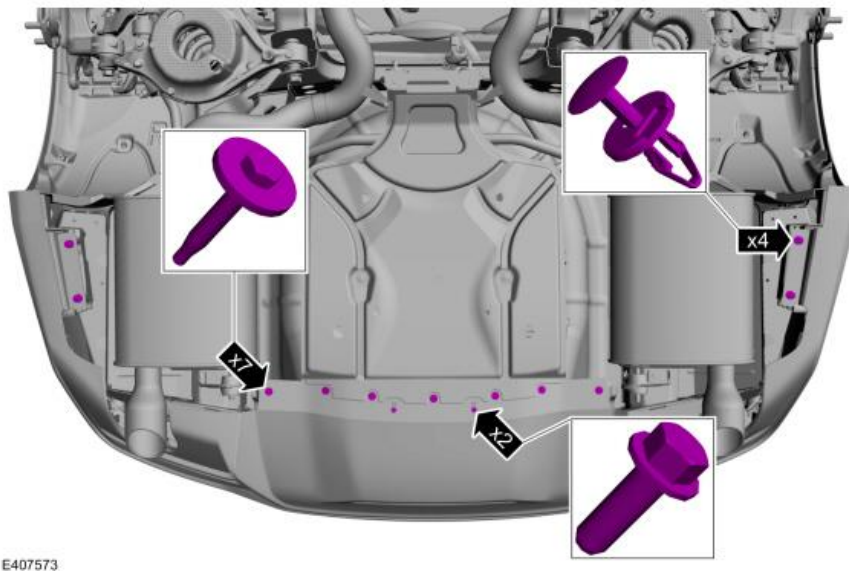

3. On both sides.
Remove the screw, the push pins and position the wheel liner aside.



FORD PERFORMANCE

M-5230-M2EB/EC/EBV/ECV/SB/SC/SBV/SCV/TBV/TCV
Model 2024+
Mustang 2.3L rear section exhaust

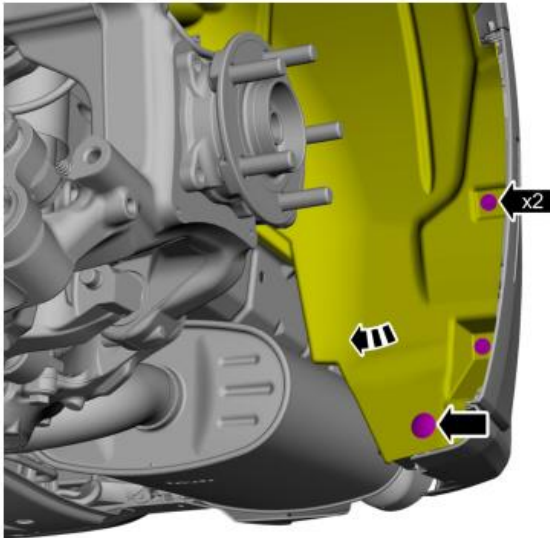

E407574

4. On both sides.
Remove the bumper cover to bracket screws. Save for later
Torque: 17 lb.in (1.9 Nm)

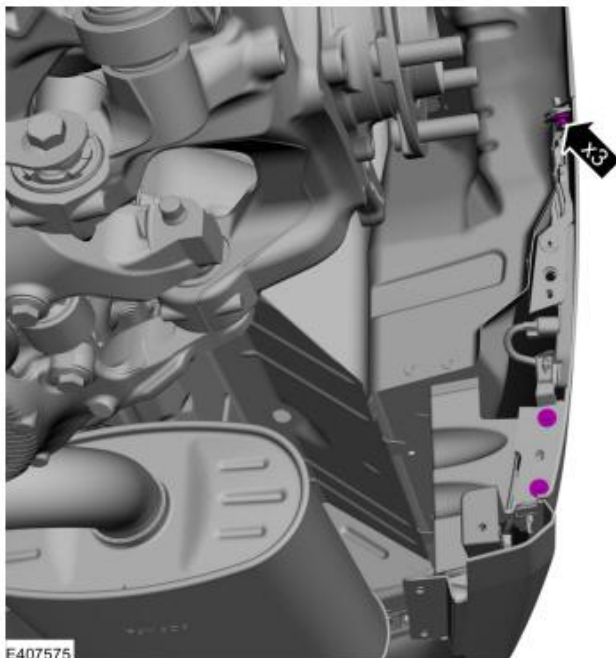

E407575

5. On both sides.
Disconnect the electrical connector and detach the wiring retainer.

Factory Ford shop manuals are available from Helm Publications, 1-800-782-4356



FORD PERFORMANCE

M-5230-M2EB/EC/EBV/ECV/SB/SC/SBV/SCV/TBV/TCV
Model 2024+
Mustang 2.3L rear section exhaust

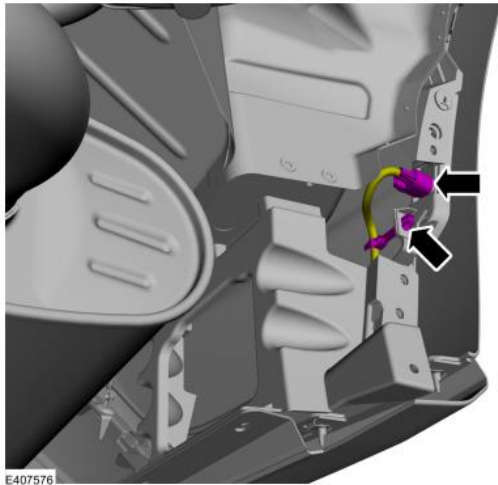

E407576

6. **NOTE:** *This step requires the aid of another technician.*

Position the rear bumper cover aside for access to electrical connector.

1. Release the sides of the rear bumper cover from the side brackets.
2. Release the rear bumper cover from the rear brackets and position aside.

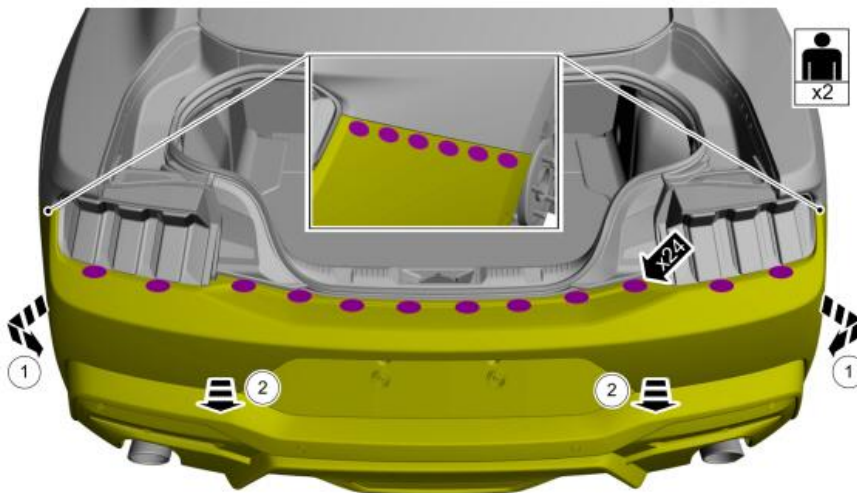

E407577

7. Disconnect the rear bumper wiring harness electrical connector.

Factory Ford shop manuals are available from Helm Publications, 1-800-782-4356



FORD PERFORMANCE

M-5230-M2EB/EC/EBV/ECV/SB/SC/SBV/SCV/TBV/TCV
Model 2024+
Mustang 2.3L rear section exhaust

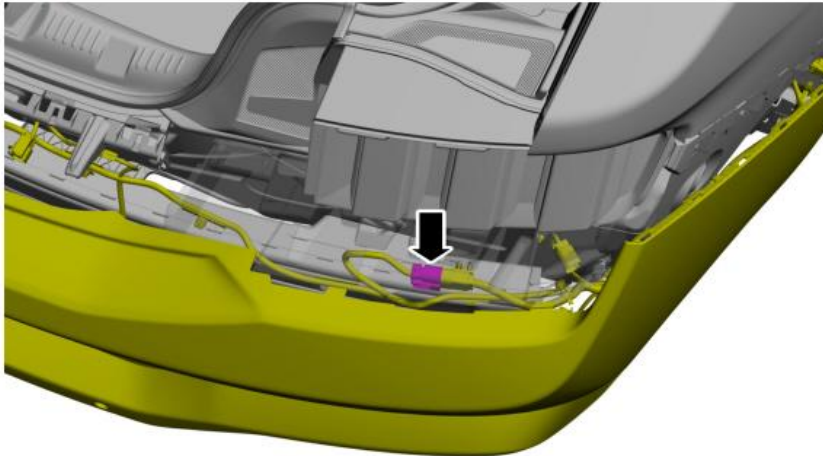

E407578

8. **NOTE:** *This step requires the aid of another technician.*

Remove the rear bumper cover.



E407579

9. Detach the wiring harness guides and position the harness aside.

Factory Ford shop manuals are available from Helm Publications, 1-800-782-4356



FORD PERFORMANCE

M-5230-M2EB/EC/EBV/ECV/SB/SC/SBV/SCV/TBV/TCV
Model 2024+
Mustang 2.3L rear section exhaust

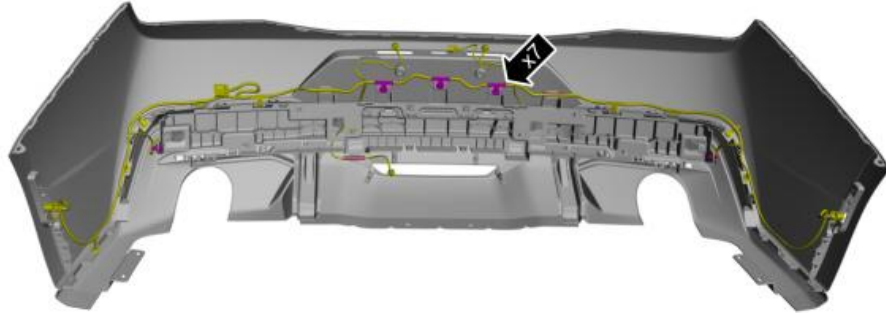

E406507

10. Remove the screws and release the tabs and remove the rear bumper cover reinforcement.

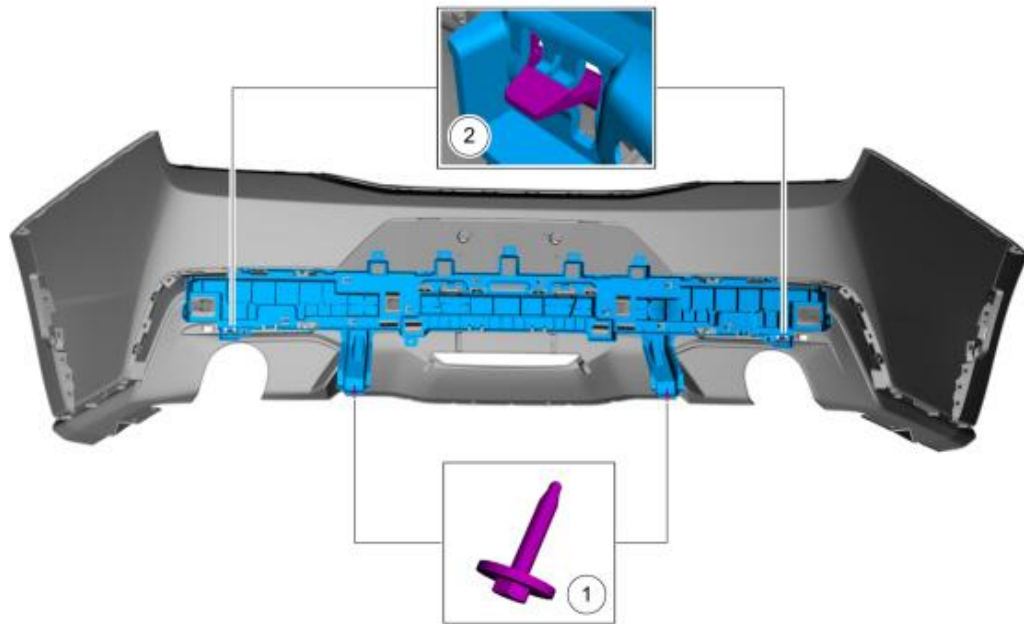

E406508

- 11.
1. Disconnect the supplemental rear marker lamp electrical connectors.
 2. Disconnect the supplemental reverse lamp electrical connector.
 3. Disconnect the rear parking aid electrical connectors.
 4. Disconnect the license plate lamp electrical connectors.
 5. Disconnect the decklid release switch electrical connector.
 6. Detach the wiring retainers and remove the rear bumper cover wiring harness

Factory Ford shop manuals are available from Helm Publications, 1-800-782-4356



FORD PERFORMANCE

M-5230-M2EB/EC/EBV/ECV/SB/SC/SBV/SCV/TBV/TCV
Model 2024+
Mustang 2.3L rear section exhaust

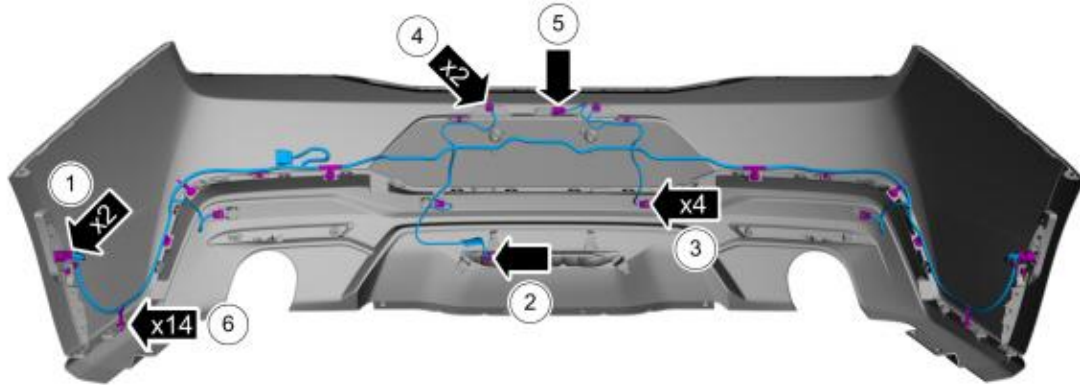

E408287

Vehicles With: Rear Parking Aid

12. NOTE: Make sure that the isolator rings are installed correctly while installing the sensors.
1. Release the tabs.
 2. Remove the rear parking aid sensors from the brackets

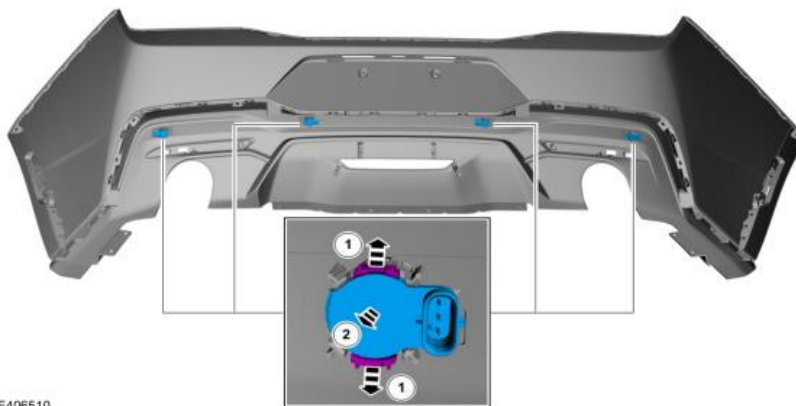

E406510

All vehicles

13. Remove the screws and the reversing lamp.
Torque: 18 lb.in (2 Nm)

Factory Ford shop manuals are available from Helm Publications, 1-800-782-4356



FORD PERFORMANCE

M-5230-M2EB/EC/EBV/ECV/SB/SC/SBV/SCV/TBV/TCV
Model 2024+
Mustang 2.3L rear section exhaust

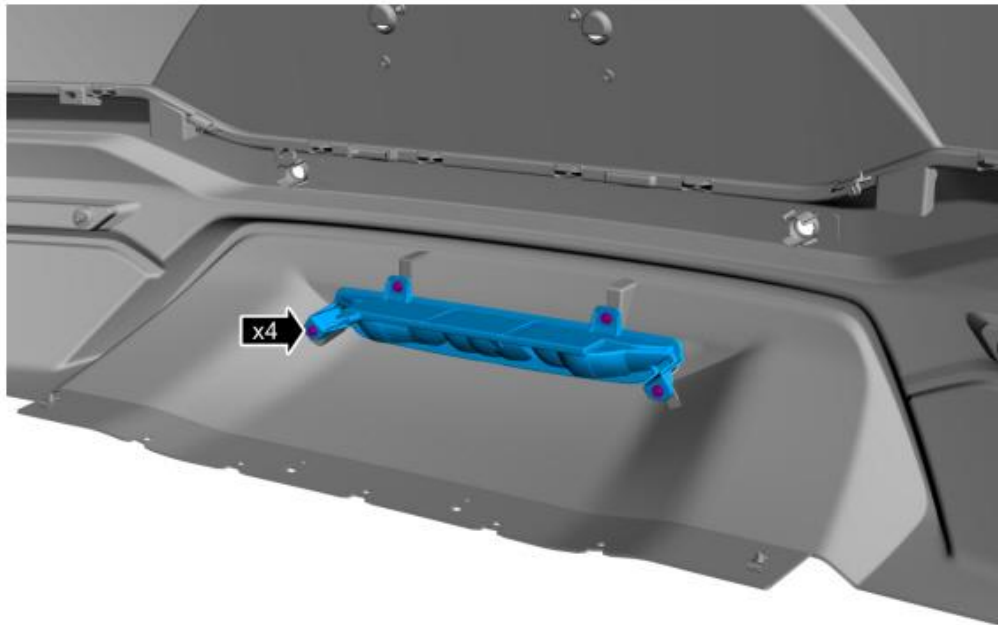

E408288

14. On both sides.
1. Remove the speed nut.
 2. Torque: 13 lb.in (1.5 Nm)

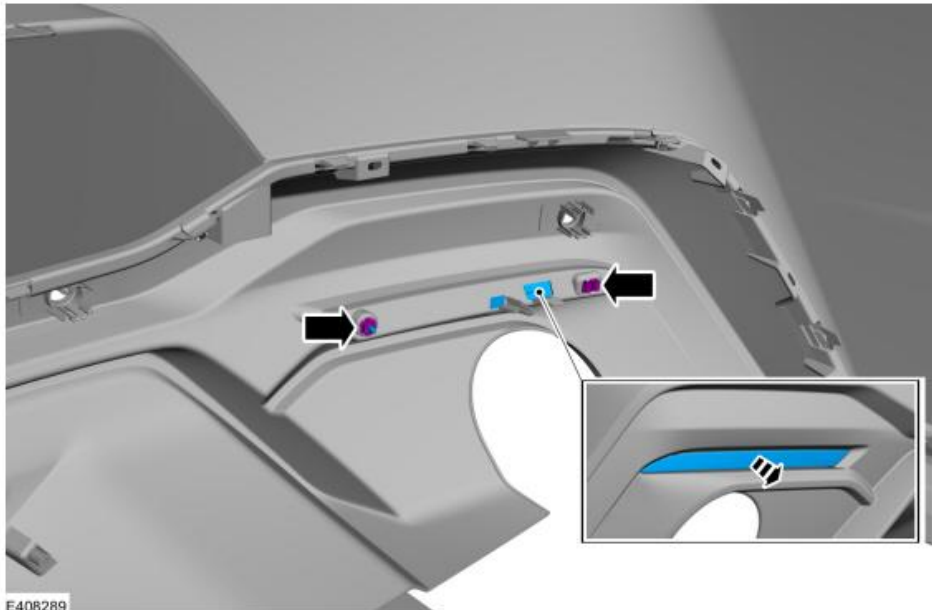

E408289

15. Remove the screws. Torque: 18 lb.in (2 Nm)
1. Remove the push pins.
 2. Release the tabs and remove the upper bumper cover.

Factory Ford shop manuals are available from Helm Publications, 1-800-782-4356



FORD PERFORMANCE

M-5230-M2EB/EC/EBV/ECV/SB/SC/SBV/SCV/TBV/TCV
Model 2024+
Mustang 2.3L rear section exhaust

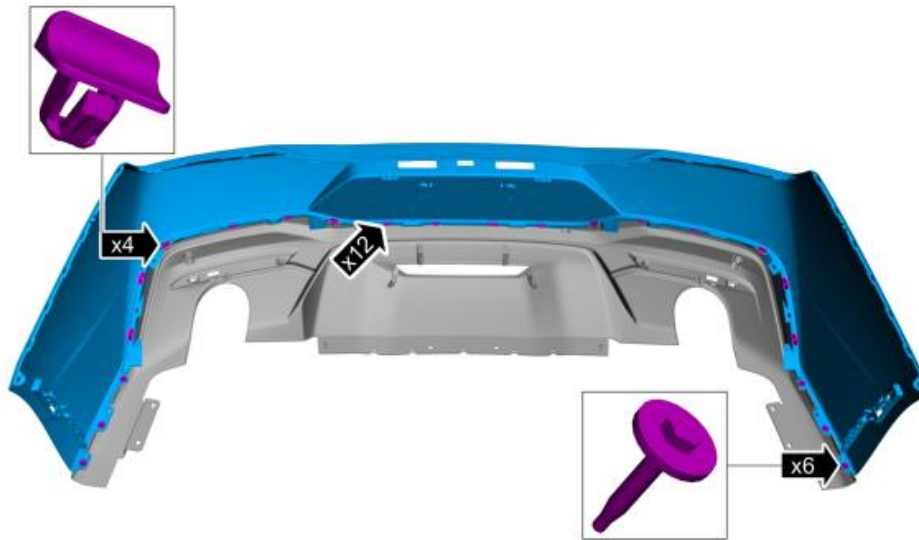

E408293

16. install the provided valence by snapping together clips and reinstalling bolts from step 15
1. **Do not reinstall rear bumper until Exhaust modification is complete and installed.**

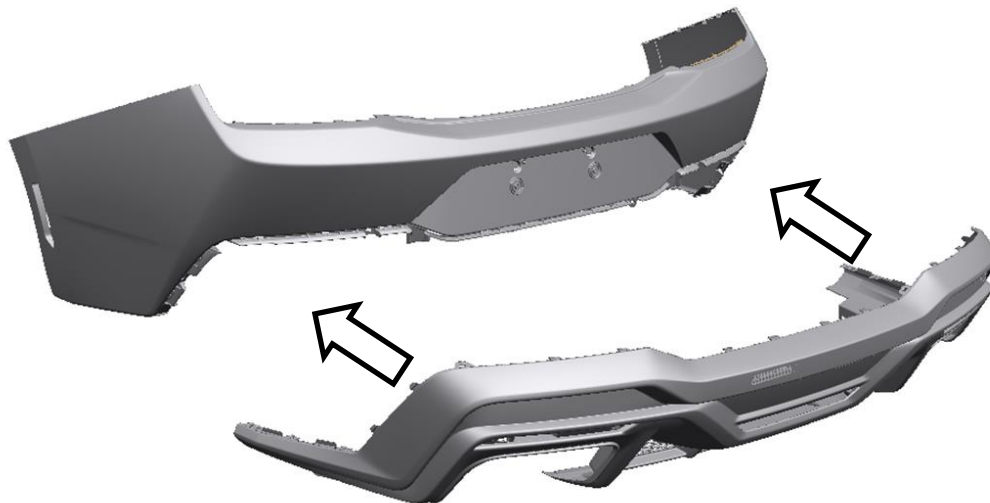

Install Borla exhaust system (PAGE 10) and reinstall valance in reverse order.

Factory Ford shop manuals are available from Helm Publications, 1-800-782-4356



FORD PERFORMANCE

M-5230-M2EB/EC/EBV/ECV/SB/SC/SBV/SCV/TBV/TCV
Model 2024+
Mustang 2.3L rear section exhaust

KIT INCLUDES:

<u>Item #</u>	<u>Qty:</u>	<u>Description</u>
1	2	Muffler
2	2	Clamp

Factory Ford shop manuals are available from Helm Publications, 1-800-782-4356



FORD PERFORMANCE

M-5230-M2EB/EC/EBV/ECV/SB/SC/SBV/SCV/TBV/TCV

Model 2024+

Mustang 2.3L rear section exhaust

Representative image for M-5230-M2EB_SB. M-5200-M2EC_SC are chrome tip versions.

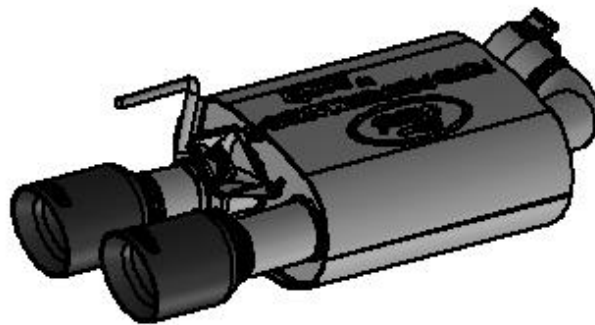
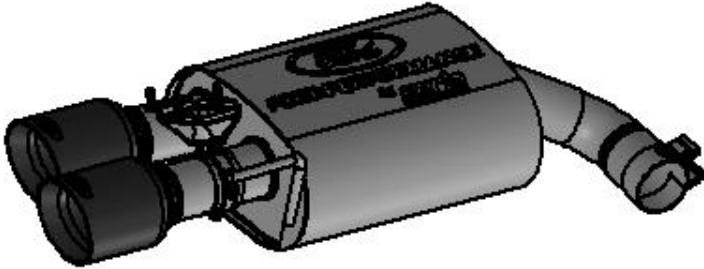

Representative image for M-5230-M2EBV_SBV_TBV. M-5200-M2ECV_SCV_TCV are chrome tip versions.

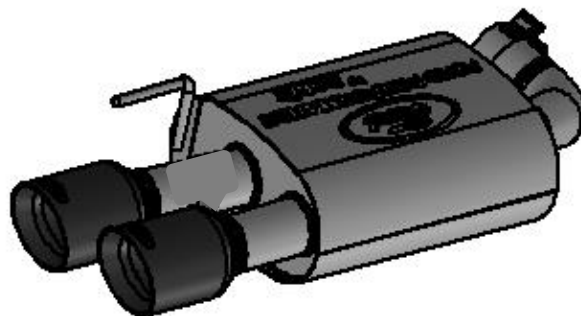

Factory Ford shop manuals are available from Helm Publications, 1-800-782-4356



FORD PERFORMANCE

M-5230-M2EB/EC/EBV/ECV/SB/SC/SBV/SCV/TBV/TCV
Model 2024+
Mustang 2.3L rear section exhaust

REMOVAL INSTRUCTIONS:

STEP 1: Rise and support vehicle.

STEP 2: Mark both drivers and passenger intermediate pipes before the last bend to muffler.

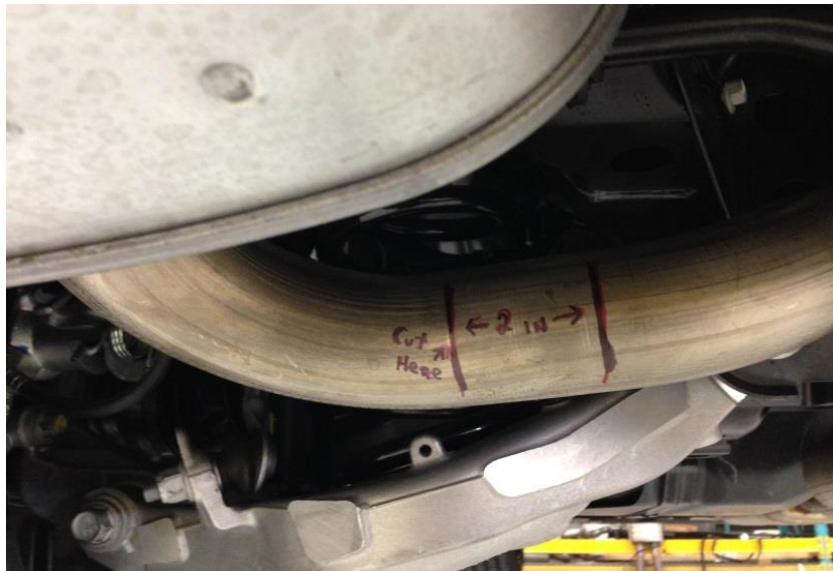

Drivers side muffler (Cut line is the start of the bend going into the muffler)



Passenger side muffler (Cut line is the start of the bend going into the muffler)

Factory Ford shop manuals are available from Helm Publications, 1-800-782-4356



FORD PERFORMANCE

M-5230-M2EB/EC/EBV/ECV/SB/SC/SBV/SCV/TBV/TCV

Model 2024+

Mustang 2.3L rear section exhaust

STEP 3: Using a metal cutting saw cut both drivers and passenger intermediate pipes at cut lines.



STEP 4: After cutting is completed remove muffler from rear hanger, deburr intermediate pipe. For vehicles with valves, disconnect the valves at the rear mufflers (LH and RH). Pull the pin holding the connector in, slide it out of the valve actuator assy.



Factory Ford shop manuals are available from Helm Publications, 1-800-782-4356



FORD PERFORMANCE

M-5230-M2EB/EC/EBV/ECV/SB/SC/SBV/SCV/TBV/TCV

Model 2024+

Mustang 2.3L rear section exhaust

INSTALLATION INSTRUCTIONS:

STEP 1: For systems with valves, the actuator will have to be removed from the factory system by removing 3 nuts as shown and attached to the valve on the new exhaust. The Factory bracket also needs to be installed in the factory location.



Factory Ford shop manuals are available from Helm Publications, 1-800-782-4356



FORD PERFORMANCE

M-5230-M2EB/EC/EBV/ECV/SB/SC/SBV/SCV/TBV/TCV

Model 2024+

Mustang 2.3L rear section exhaust



STEP 1: (cont'd) As the muffler is raised into position, attach the cable to the valve on each side.



STEP 2: Install drivers hand muffler into rear hanger slide clamp onto muffler pipe, slide muffler onto the pipe that you just cut. Position tips in

Factory Ford shop manuals are available from Helm Publications, 1-800-782-4356



FORD PERFORMANCE

M-5230-M2EB/EC/EBV/ECV/SB/SC/SBV/SCV/TBV/TCV

Model 2024+

Mustang 2.3L rear section exhaust

bumper cutout and torque clamp to 48Nm (35 lb-ft).



Step 3: Install passenger hand muffler into rear hanger slide clamp onto muffler pipe, slide muffler onto the pipe that you just cut. Position tips in cutout and torque clamp to 48Nm (35 lb-ft).



Factory Ford shop manuals are available from Helm Publications, 1-800-782-4356



FORD PERFORMANCE

M-5230-M2EB/EC/EBV/ECV/SB/SC/SBV/SCV/TBV/TCV

Model 2024+

Mustang 2.3L rear section exhaust

Step 7: Check all fasteners for proper torque.

Step 8: Check alignment of tips in rear bumper cover and clearance to all parts under the vehicle.



STEP 9: Lower vehicle. Start vehicle and check for any leaks. If any leaks are found, determine cause (such as loose or incorrectly positioned clamp) and repair as necessary.

Congratulations!!! You have completed the installation of your new Ford Performance Parts Exhaust Kit.

Note: When you first start your vehicle after the installation of your new Ford Performance Parts Exhaust System, there may be some smoke and fumes coming from the system. This is a protective water based coating used in the manufacturing of mandrel bent performance exhaust tubing. This is not a problem and will disappear within a very short period of time after the exhaust has reached operating temperatures.

Factory Ford shop manuals are available from Helm Publications, 1-800-782-4356