



M-6004-A5015
2015-2017 Mustang 5.0L
Chain-drive kit

NO PART OF THIS DOCUMENT MAY BE REPRODUCED WITHOUT PRIOR AGREEMENT AND WRITTEN PERMISSION OF
FORD PERFORMANCE PARTS

PRIOR TO INSTALLATION READ THESE INSTRUCTION COMPLETELY
For questions, Call the FORD PERFORMANCE Techline 1-800-367-3788

Please visit <https://www.performanceparts.ford.com> for warranty information

Part #	Description	Qty
9L8Z-6C683-A	VCT/camshaft filter	4
BR3Z-6A340-A	Damper bolt	1
BR3Z-6268-A	Secondary timing chain	2
BR3Z-6B274-A	Chain guide	1
BR3Z-6M256-A	Chain guide	1
CR3Z-6K255-A	Tensioner arm	2
CR3Z-6L266-A	Primary chain tensioner	2
FR3Z-6268-A	Primary timing chain	2
BR3Z-6279-A	VCT phaser bolt	12
FR3Z-6256-C	Intake VCT sprocket	2
FR3Z-6C525-C	Exhaust VCT sprocket	2
KR3Z-6306-B	Crank sprocket	1
ML3Z-6K254-A	Secondary chain tensioner	2
ML3Z-6K297-A	Secondary tensioner guide	2
N806183-S437	Oil pump bolt	2
N807033-S439	Damper bolt washer	1
W503282-S437	Chain guide bolt	2
W701501-S	Dowel	1
W714251-S300	Oil pump stud bolt	1
W714252-S300	Oil pump stud bolt	1
W714258-S300	Dowel	3
N807352-S300	Primary tensioner bolt	4

Ford Factory Shop Manual purchase options www.motorcraftservice.com



FORD PERFORMANCE

M-6004-A5015 2015-2017 Mustang 5.0L Chain-drive kit

NO PART OF THIS DOCUMENT MAY BE REPRODUCED WITHOUT PRIOR AGREEMENT AND WRITTEN PERMISSION OF FORD PERFORMANCE PARTS

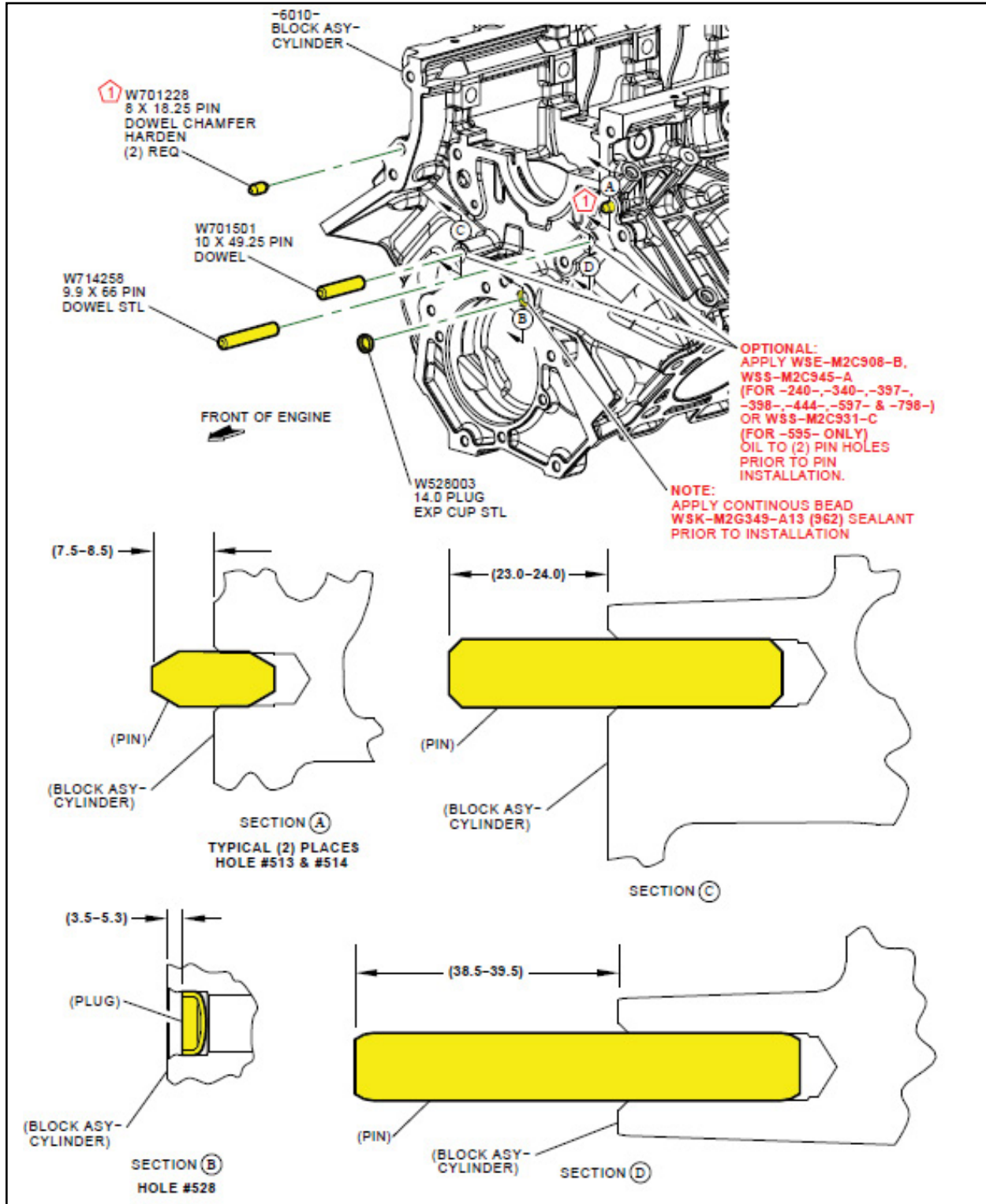

Ford Factory Shop Manual purchase options www.motorcraftservice.com



FORD PERFORMANCE

M-6004-A5015 2015-2017 Mustang 5.0L Chain-drive kit

NO PART OF THIS DOCUMENT MAY BE REPRODUCED WITHOUT PRIOR AGREEMENT AND WRITTEN PERMISSION OF FORD PERFORMANCE PARTS

NOTE:
BACKGROUND DETAIL NOT PICTORIALLY ACCURATE FOR ALL APPLICATIONS

W714252 (9mm HEX)
M8 X 1.25 X 45 +
10 X 24 PIN & WASHER
HEX PILOT CONICAL
TORQUE 20 Nm THEN
ROTATE 55°- 65° CLOCKWISE

W714251 (13mm HEX)
M8 X 1.25 X 52 + 9 X 24 PIN & WSHR
HEX FLNG HD PILOT CONICAL
TORQUE 25 Nm THEN
ROTATE 70°- 80° CLOCKWISE

N806183 (8mm HEX)
M6 X 1 X 42.5 BOLT
HEX FLNG HD PILOT
TORQUE 10 Nm THEN
ROTATE 40°- 50° CLOCKWISE
(2) REQ

-6621-
PUMP ASY-OIL LESS
SCREEN & COVER

(CRANKSHAFT)

(BLOCK ASY-CYLINDER)

FRONT OF ENGINE

ASSEMBLY PROCEDURE

1. ROTATE INNER ROTOR OF OIL PUMP ASY (-6621-) TO ALIGN WITH FLATS ON CRANKSHAFT POST AND SLIP OIL PUMP OVER UNTIL SEATED AGAINST BLOCK.
NOTE:
PUMP MUST BE HELD AGAINST BLOCK UNTIL BOLTS ARE TORQUED.
2. ROTATE OIL PUMP ASY, ALIGN BOLT HOLES, INSTALL (4) FASTENERS AND SIMULTANEOUSLY TORQUE TO SPECIFICATION.
NOTE:
FOR PRODUCTION, ROTATION OF CRANKSHAFT DURING TORQUE PROCEDURE IS REQUIRED.

SINGLE WRENCH METHOD (SERVICE)

1. ROTATE INNER ROTOR OF OIL PUMP ASY TO ALIGN WITH FLATS ON CRANKSHAFT POST AND SLIP OIL PUMP OVER UNTIL SEATED AGAINST BLOCK.
NOTE:
PUMP MUST BE HELD AGAINST BLOCK UNTIL BOLTS ARE TORQUED.
2. ROTATE OIL PUMP ASY, ALIGN BOLT HOLES, INSTALL (4) FASTENERS.
3. TORQUE FASTENERS 0 Nm.
4. TORQUE M8 FASTENER W714251 25 Nm, M8 FASTENER W714252 20 Nm AND M6 FASTENERS N806183 10 Nm.
5. ROTATE M8 FASTENER W714251 70°- 80° CLOCKWISE, ROTATE M8 FASTENER W714252 55°- 65° CLOCKWISE AND M6 FASTENERS N806183 40°- 50° CLOCKWISE.

Ford Factory Shop Manual purchase options www.motorcraftservice.com



FORD PERFORMANCE

M-6004-A5015
2015-2017 Mustang 5.0L
Chain-drive kit

NO PART OF THIS DOCUMENT MAY BE REPRODUCED WITHOUT PRIOR AGREEMENT AND WRITTEN PERMISSION OF FORD PERFORMANCE PARTS

LH (Driver's side) camshaft neutral position

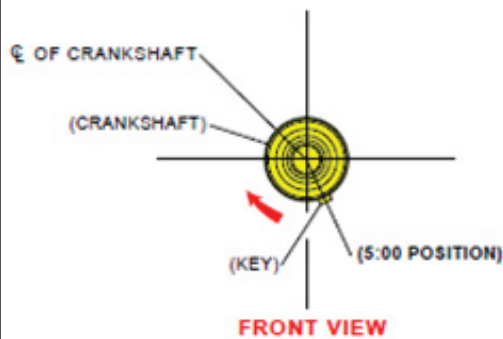
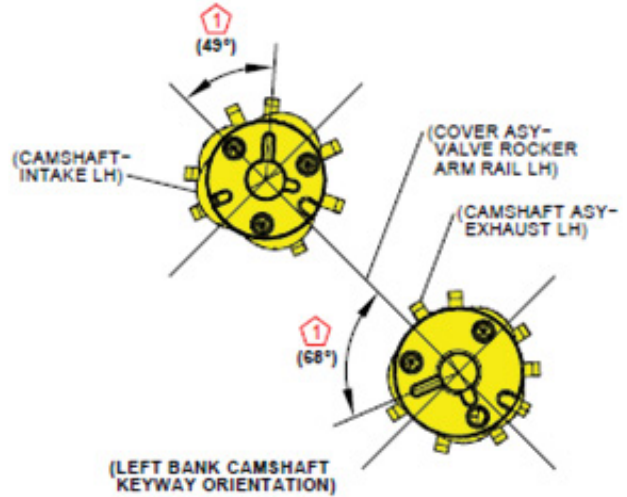

NOTE:
CRANKSHAFT MUST BE
ROTATED CLOCKWISE ONLY

NOTE:
CRANKSHAFT, CAMSHAFTS, PRIMARY SPROCKETS & CHAINS, MUST BE POSITIONED TO SPECIFICATION SHOWN, PRIOR TO FASTENER INSTALLATION AND PRELIMINARY RUNDOWN.

1 REPRESENTS APPROXIMATE CAMSHAFT KEYWAY POSITIONS WHEN CAMSHAFTS ARE IN NEUTRAL POSITION SHOWN.

Ford Factory Shop Manual purchase options www.motorcraftservice.com



FORD PERFORMANCE

M-6004-A5015
2015-2017 Mustang 5.0L
Chain-drive kit

NO PART OF THIS DOCUMENT MAY BE REPRODUCED WITHOUT PRIOR AGREEMENT AND WRITTEN PERMISSION OF FORD PERFORMANCE PARTS

NOTE: Do not remove the secondary timing chain tensioner shipping clip, until instructed to do so.

NOTE: The secondary timing chain tensioner and shoe are of a new design. The secondary timing chain tensioner is shorter than the previous design and does not extend through the bottom of the camshaft mega cap. The new design shoe has tabs that contact the front of the mega cap when installed.

Apply clean engine oil to the secondary timing chain tensioner O-ring seals and mega cap bore.

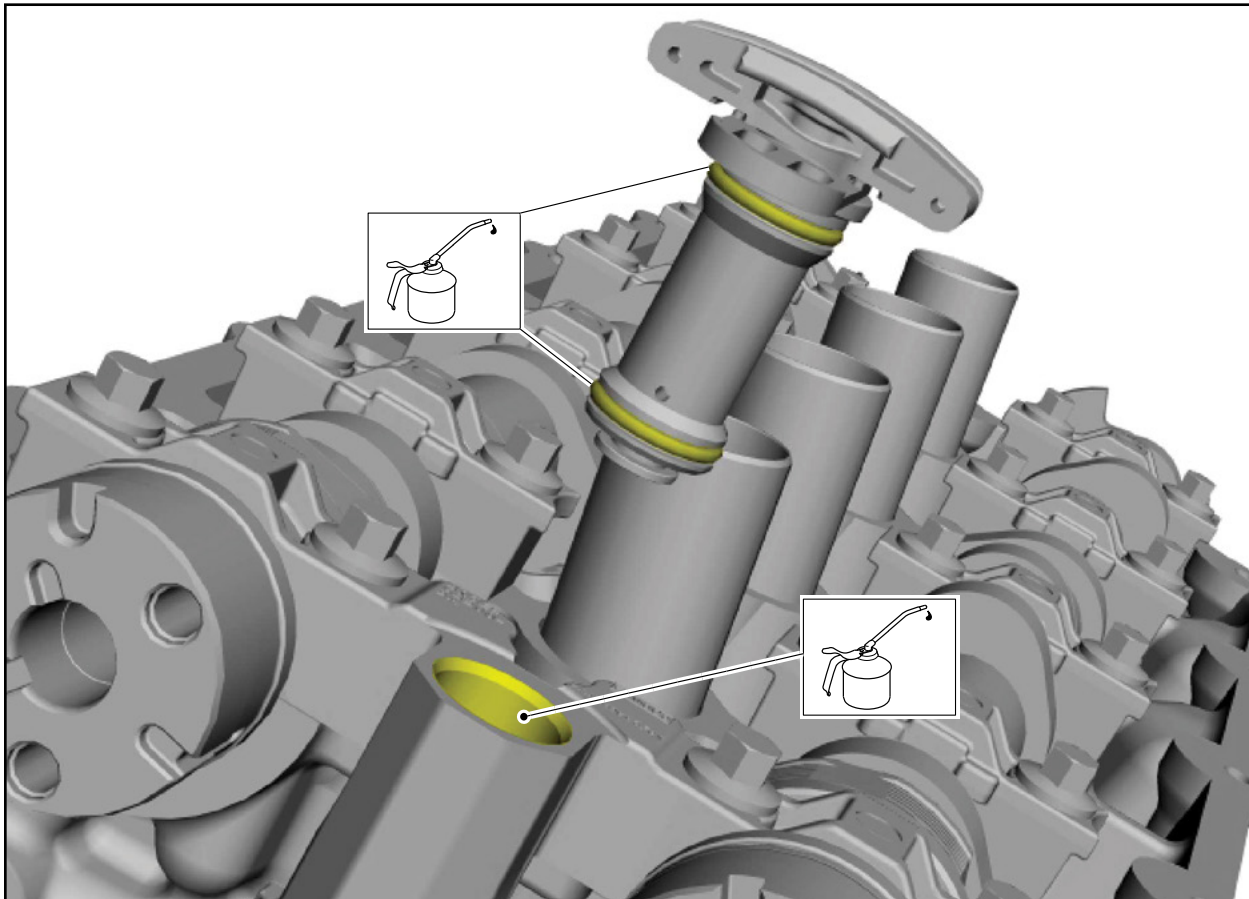

Ford Factory Shop Manual purchase options www.motorcraftservice.com



FORD PERFORMANCE

M-6004-A5015 2015-2017 Mustang 5.0L Chain-drive kit

NO PART OF THIS DOCUMENT MAY BE REPRODUCED WITHOUT PRIOR AGREEMENT AND WRITTEN PERMISSION OF FORD PERFORMANCE PARTS

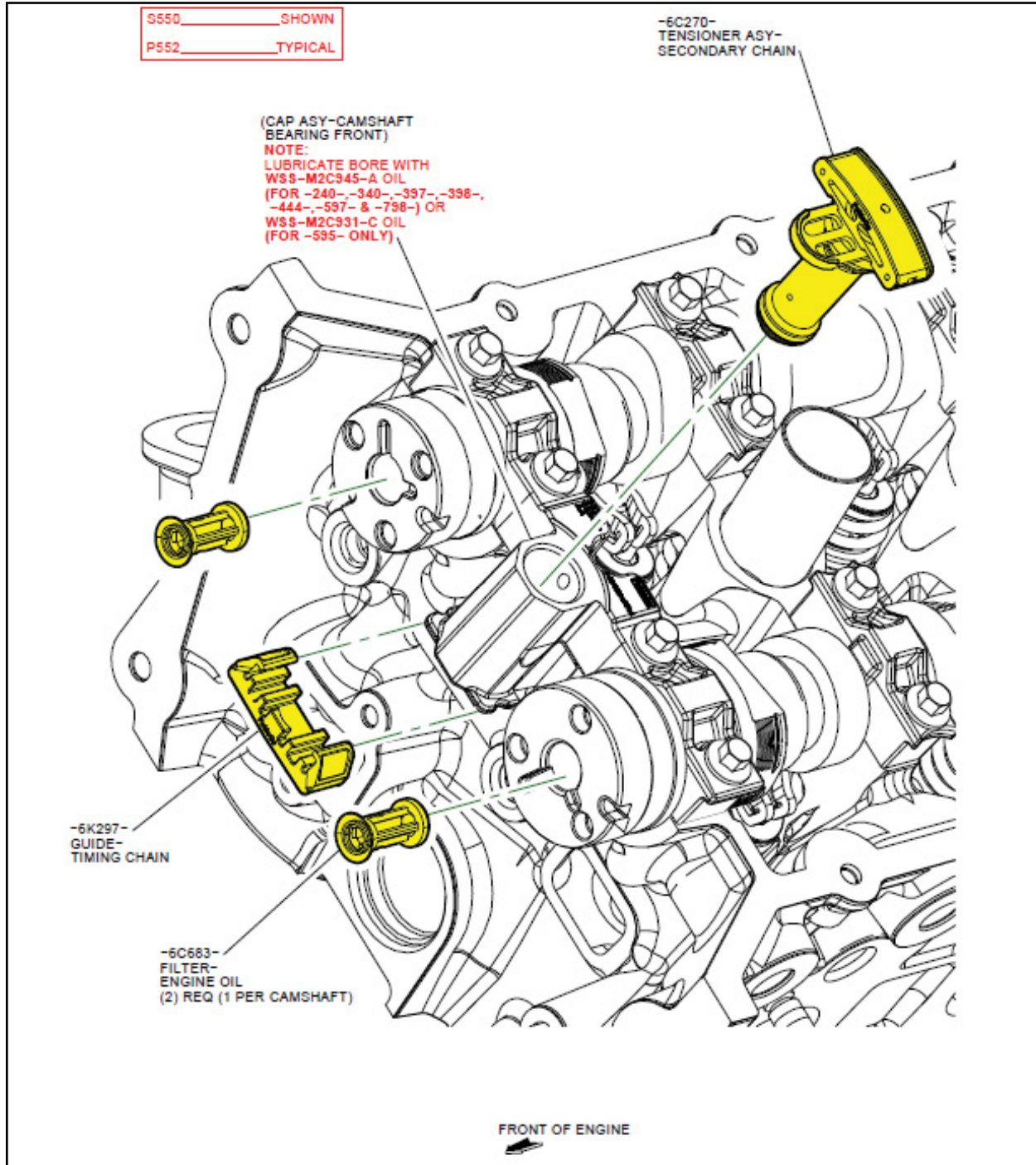

Ford Factory Shop Manual purchase options www.motorcraftservice.com



FORD PERFORMANCE

M-6004-A5015
2015-2017 Mustang 5.0L
Chain-drive kit

NO PART OF THIS DOCUMENT MAY BE REPRODUCED WITHOUT PRIOR AGREEMENT AND WRITTEN PERMISSION OF FORD PERFORMANCE PARTS

Install the secondary timing chain tensioner by pushing it down all the way until a snap is heard and the tensioner is seated all the way down the mega cap bore.

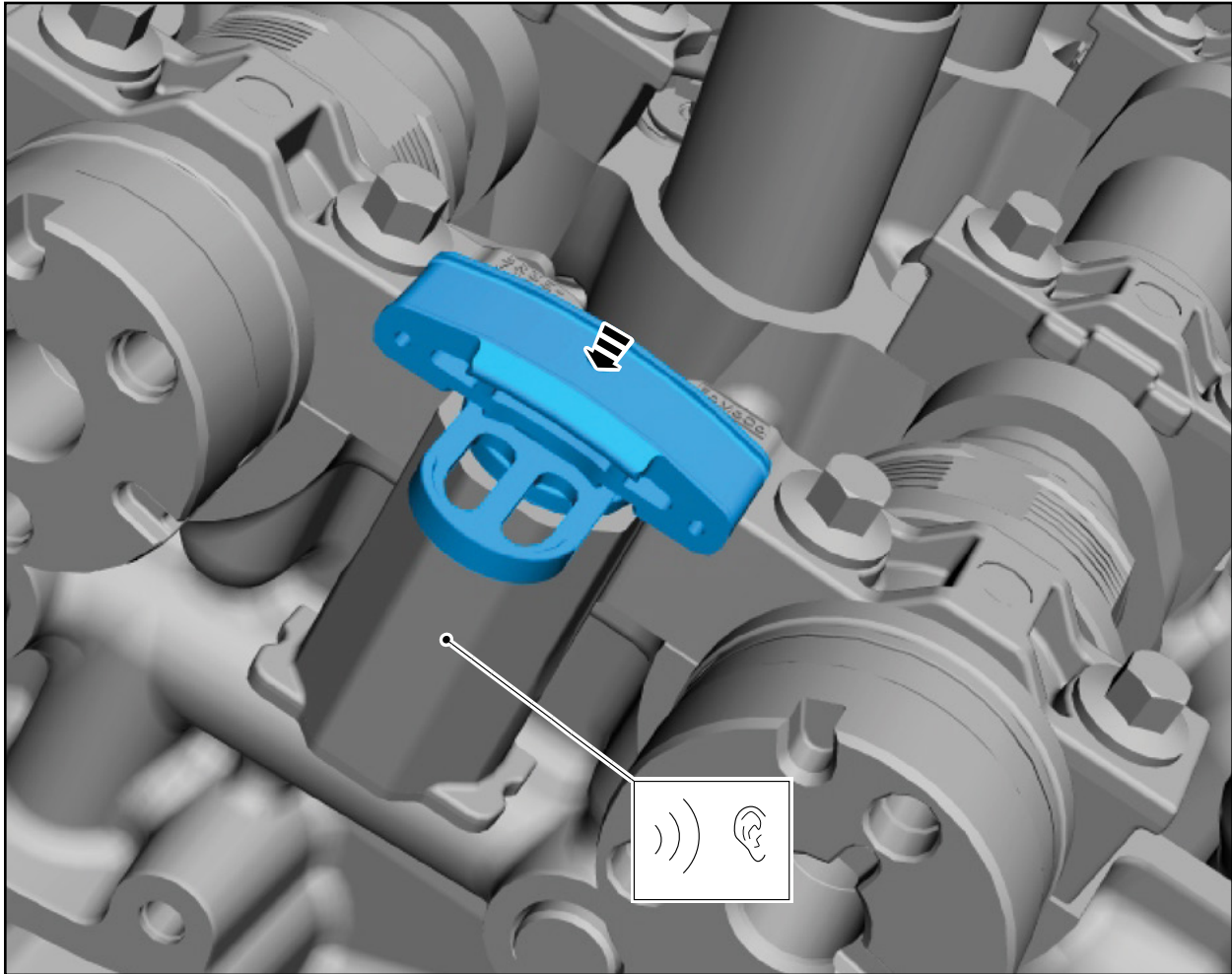

Ford Factory Shop Manual purchase options www.motorcraftservice.com



FORD PERFORMANCE

M-6004-A5015
2015-2017 Mustang 5.0L
Chain-drive kit

NO PART OF THIS DOCUMENT MAY BE REPRODUCED WITHOUT PRIOR AGREEMENT AND WRITTEN PERMISSION OF
FORD PERFORMANCE PARTS

Install the secondary timing chain tensioner shoe.

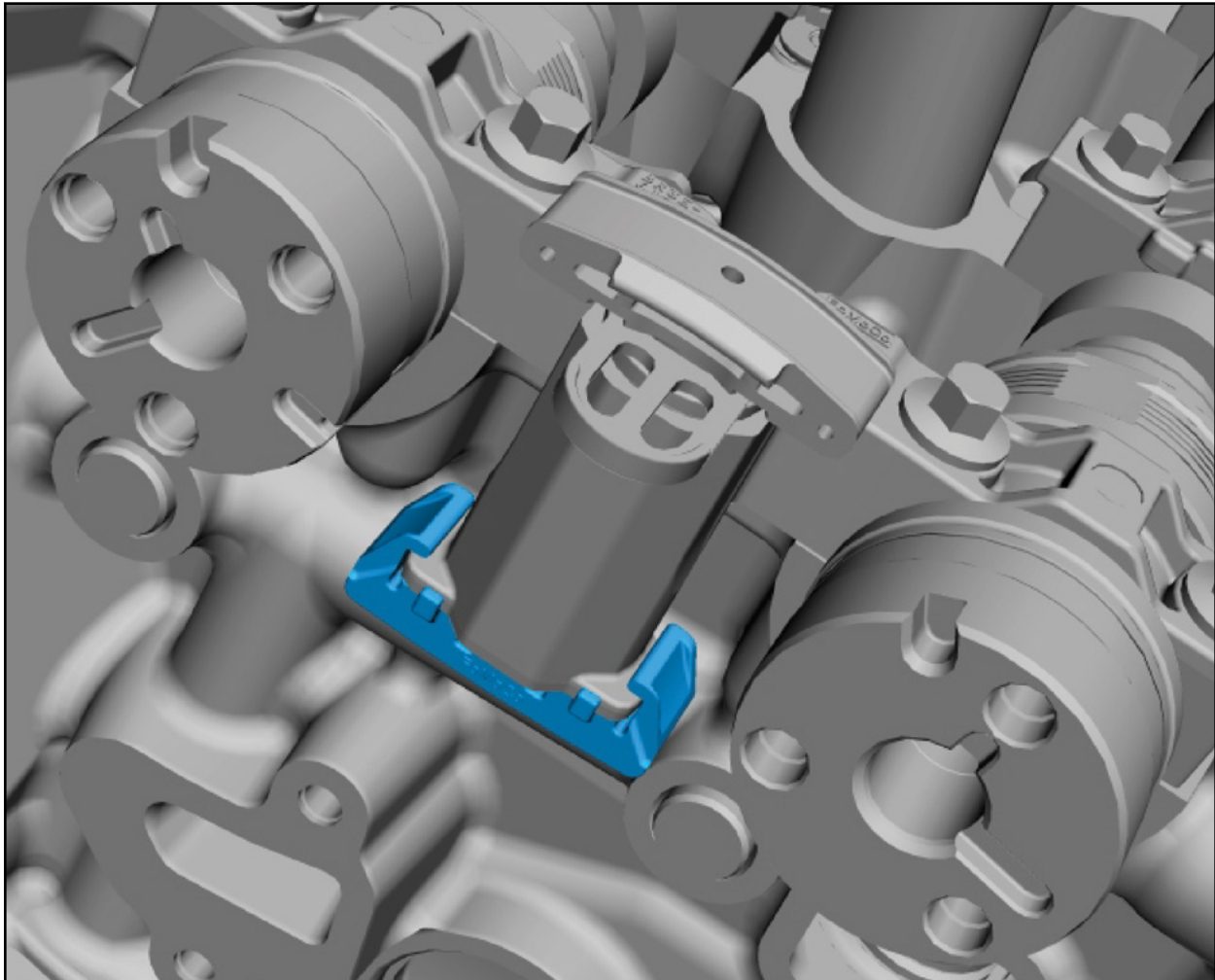

Ford Factory Shop Manual purchase options www.motorcraftservice.com



FORD PERFORMANCE

M-6004-A5015 2015-2017 Mustang 5.0L Chain-drive kit

NO PART OF THIS DOCUMENT MAY BE REPRODUCED WITHOUT PRIOR AGREEMENT AND WRITTEN PERMISSION OF FORD PERFORMANCE PARTS

LH SECONDARY CHAIN CAMSHAFT INTAKE TO EXHAUST AND ENGINE VARIABLE CAMSHAFT TIMING ASY FOR S550 ONLY

NOTE:
PRE-ASSEMBLE SECONDARY CHAIN TO INTAKE & EXHAUST VCT UNITS. MARKED LINK PLATES LINE UP WITH TIMING MARKS ON ON BOTH INTAKE & EXHAUST VCT UNITS. ALIGN AS SHOWN IN VIEW A.

(TENSIONER ASY-
SECONDARY CHAIN)
NOTE:
REMOVE CLIP AFTER
VCT AND SECONDARY
CHAIN INSTALLATION.
PUSH DOWN AND
DISENGAGE.

(HEAD ASY-
CYLINDER LH)

-6C256-
CHAIN-CAMSHAFT INTAKE
TO EXHAUST SECONDARY

-6C524-
CAMSHAFT TIMING ASY-
ENGINE VARIABLE INTAKE

-6279- (10mm 12 PT)
M7 X 1 X 44 BOLT
EXTR LOBE PILOT
TORQUE 15 Nm THEN
ROTATE 90° CLOCKWISE
(6) REQ (3 PER PHASER)

-6C525-
CAMSHAFT TIMING ASY-
ENGINE VARIABLE EXHAUST

NOTE:
ENSURE CORRECT S550
SPECIFIC PART IS USED
(SEE VIEW B)

(BLUE TIMING
LINKS)
(2) PLACES

(TIMING MARK)

FRONT OF ENGINE

(S550 SPECIFIC
IDENTIFICATION
BUMP)

(CAMSHAFT TIMING ASY-
ENGINE VARIABLE INTAKE)

(CHAIN-CAMSHAFT
INTAKE TO
EXHAUST
SECONDARY)

(CAMSHAFT
TIMING ASY-
ENGINE
VARIABLE
EXHAUST)

(TIMING MARK)

VIEW A

(CAMSHAFT TIMING ASY-
ENGINE VARIABLE EXHAUST)

VIEW B

(BLUE TIMING
LINKS)
(2) PLACES

(TIMING MARK)

FRONT OF ENGINE

(S550 SPECIFIC
IDENTIFICATION
BUMP)

(CAMSHAFT TIMING ASY-
ENGINE VARIABLE INTAKE)

(CHAIN-CAMSHAFT
INTAKE TO
EXHAUST
SECONDARY)

(CAMSHAFT
TIMING ASY-
ENGINE
VARIABLE
EXHAUST)

(TIMING MARK)

VIEW A

(CAMSHAFT TIMING ASY-
ENGINE VARIABLE EXHAUST)

VIEW B

Ford Factory Shop Manual purchase options www.motorcraftservice.com



FORD PERFORMANCE

M-6004-A5015
2015-2017 Mustang 5.0L
Chain-drive kit

NO PART OF THIS DOCUMENT MAY BE REPRODUCED WITHOUT PRIOR AGREEMENT AND WRITTEN PERMISSION OF FORD PERFORMANCE PARTS

Remove and discard the secondary timing chain tensioner shipping clip.

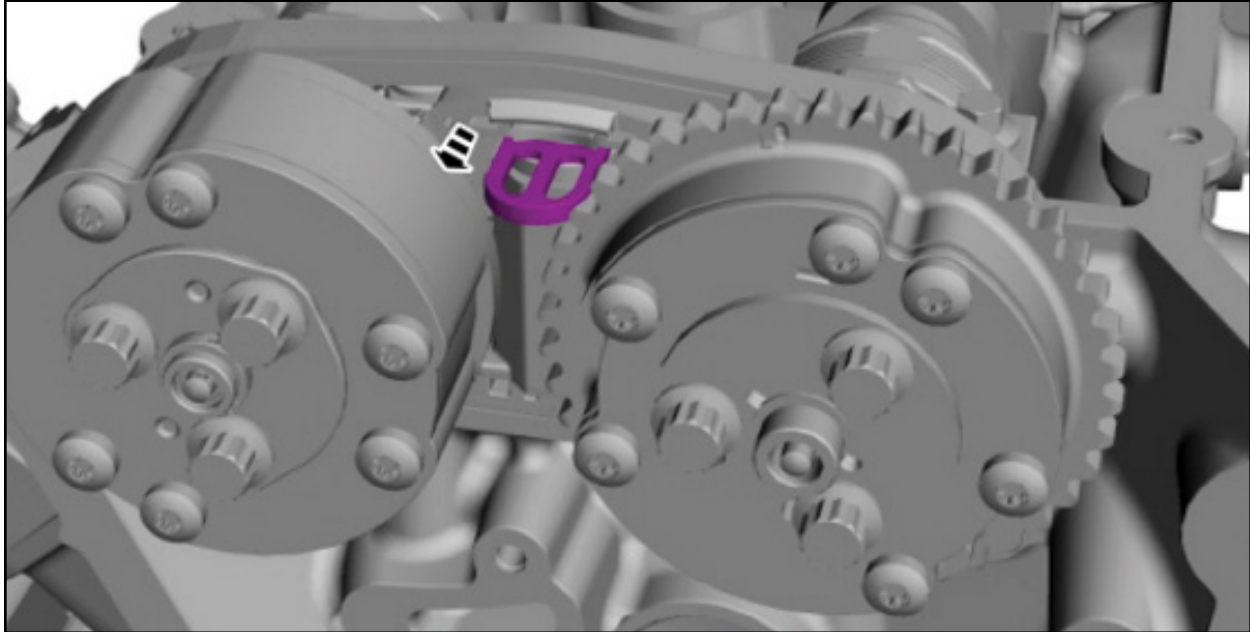

Activate the secondary timing chain tensioner by pressing down on the secondary timing chain and tensioner top shoe until it bottoms out, let go of the tensioner and it will spring up putting tension on the chain.

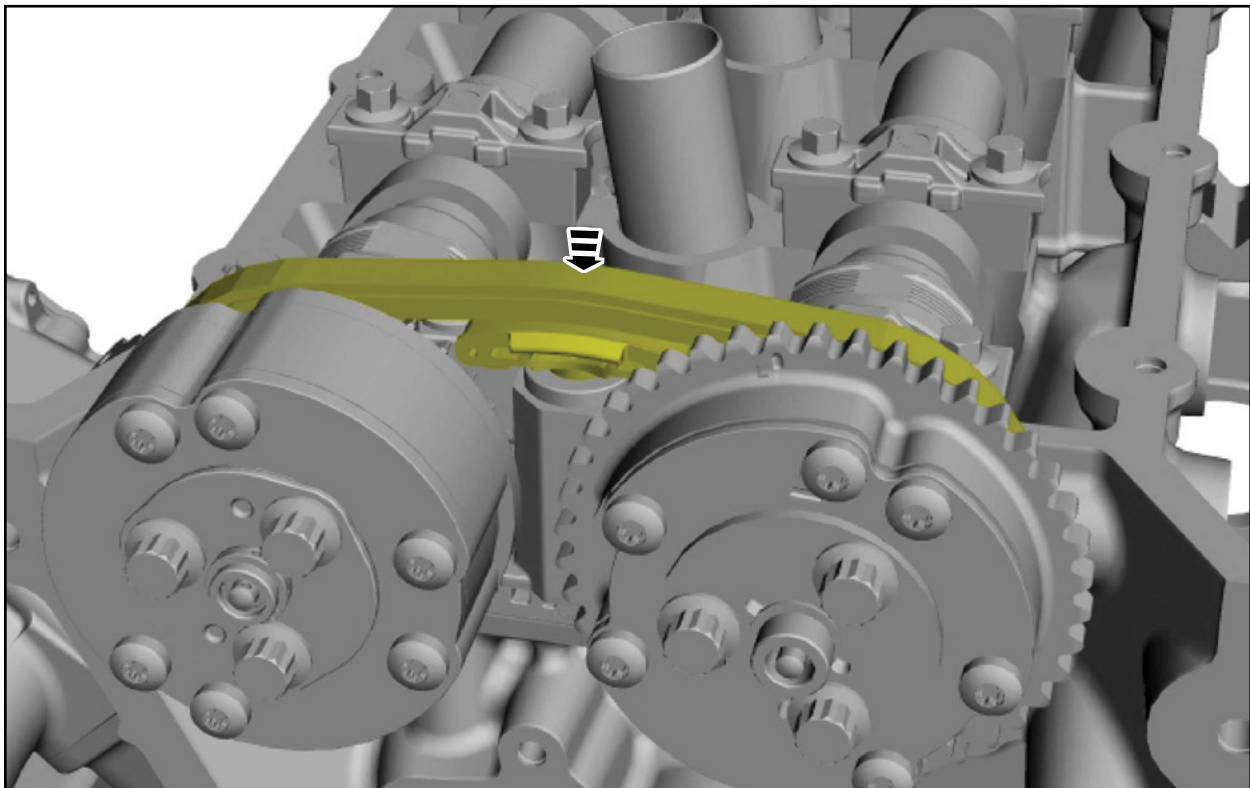

Ford Factory Shop Manual purchase options www.motorcraftservice.com



FORD PERFORMANCE

M-6004-A5015
2015-2017 Mustang 5.0L
Chain-drive kit

NO PART OF THIS DOCUMENT MAY BE REPRODUCED WITHOUT PRIOR AGREEMENT AND WRITTEN PERMISSION OF FORD PERFORMANCE PARTS

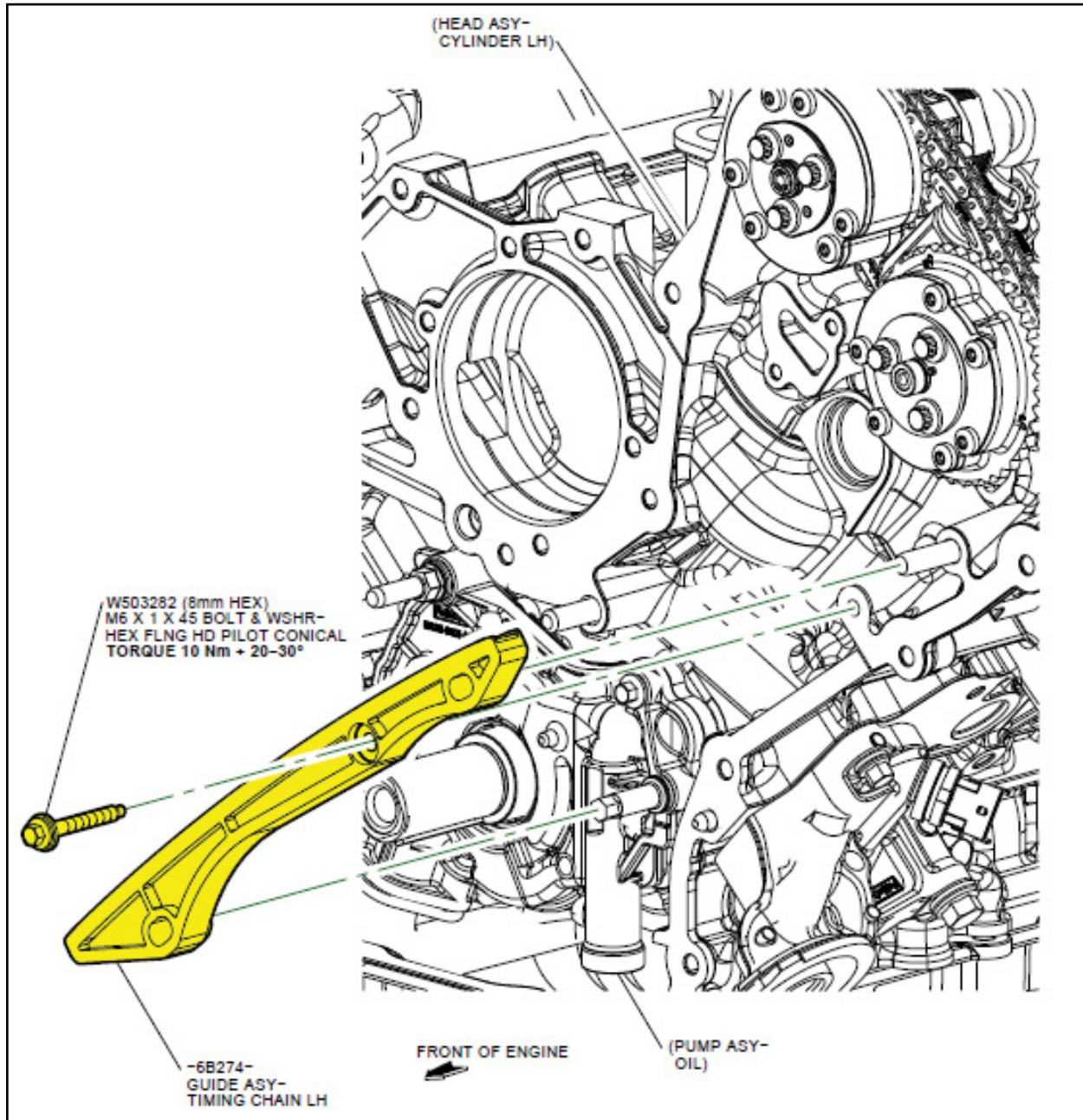

Ford Factory Shop Manual purchase options www.motorcraftservice.com



FORD PERFORMANCE

M-6004-A5015
2015-2017 Mustang 5.0L
Chain-drive kit

NO PART OF THIS DOCUMENT MAY BE REPRODUCED WITHOUT PRIOR AGREEMENT AND WRITTEN PERMISSION OF FORD PERFORMANCE PARTS

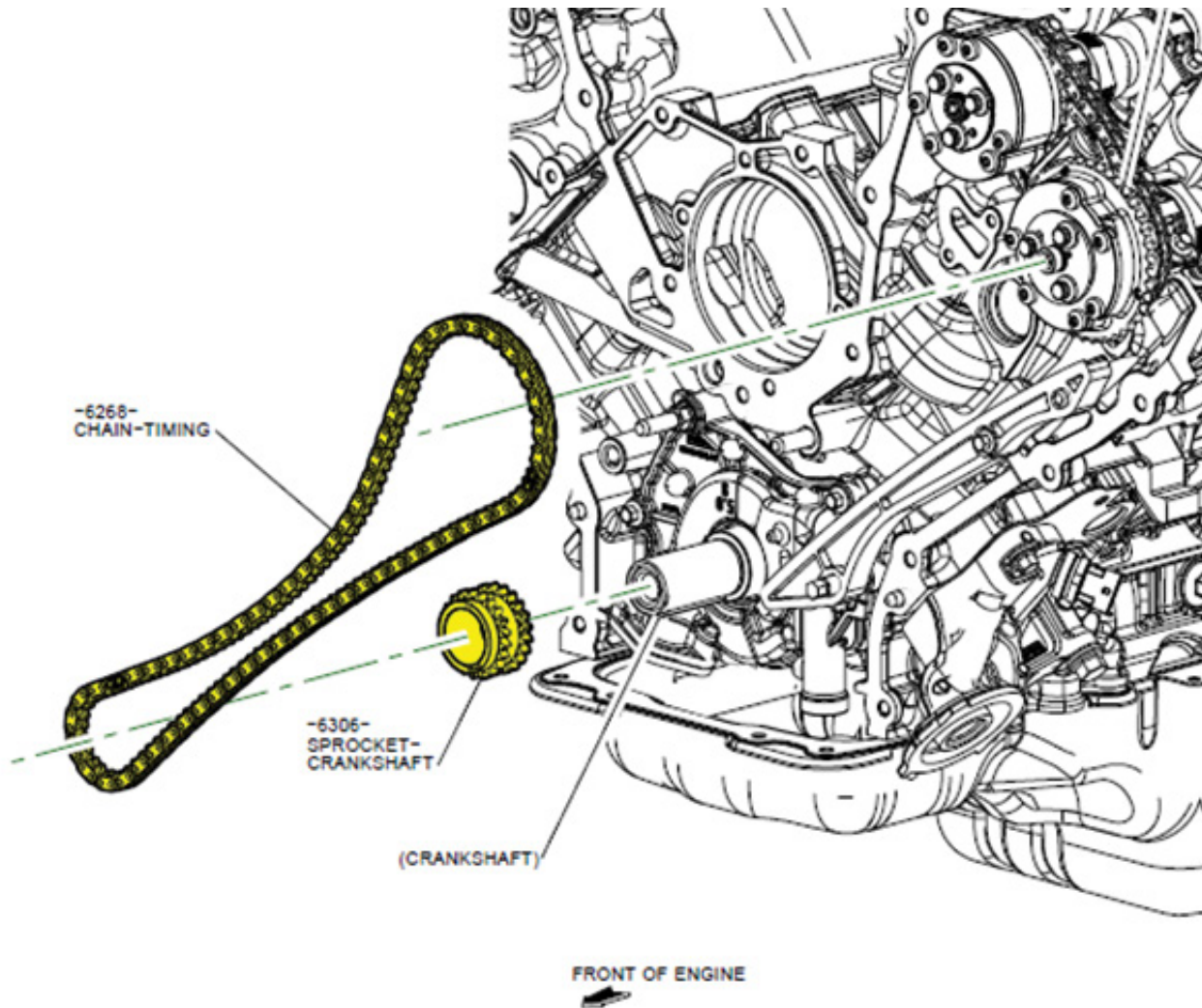

Ford Factory Shop Manual purchase options www.motorcraftservice.com



FORD PERFORMANCE

M-6004-A5015 2015-2017 Mustang 5.0L Chain-drive kit

NO PART OF THIS DOCUMENT MAY BE REPRODUCED WITHOUT PRIOR AGREEMENT AND WRITTEN PERMISSION OF FORD PERFORMANCE PARTS

TIMING CHAIN TENSIONER ARM ASY AND TIMING CHAIN TENSIONER LH

S197 _____ SHOWN
P415/BOSS/
LAGUNA _____ TYPICAL

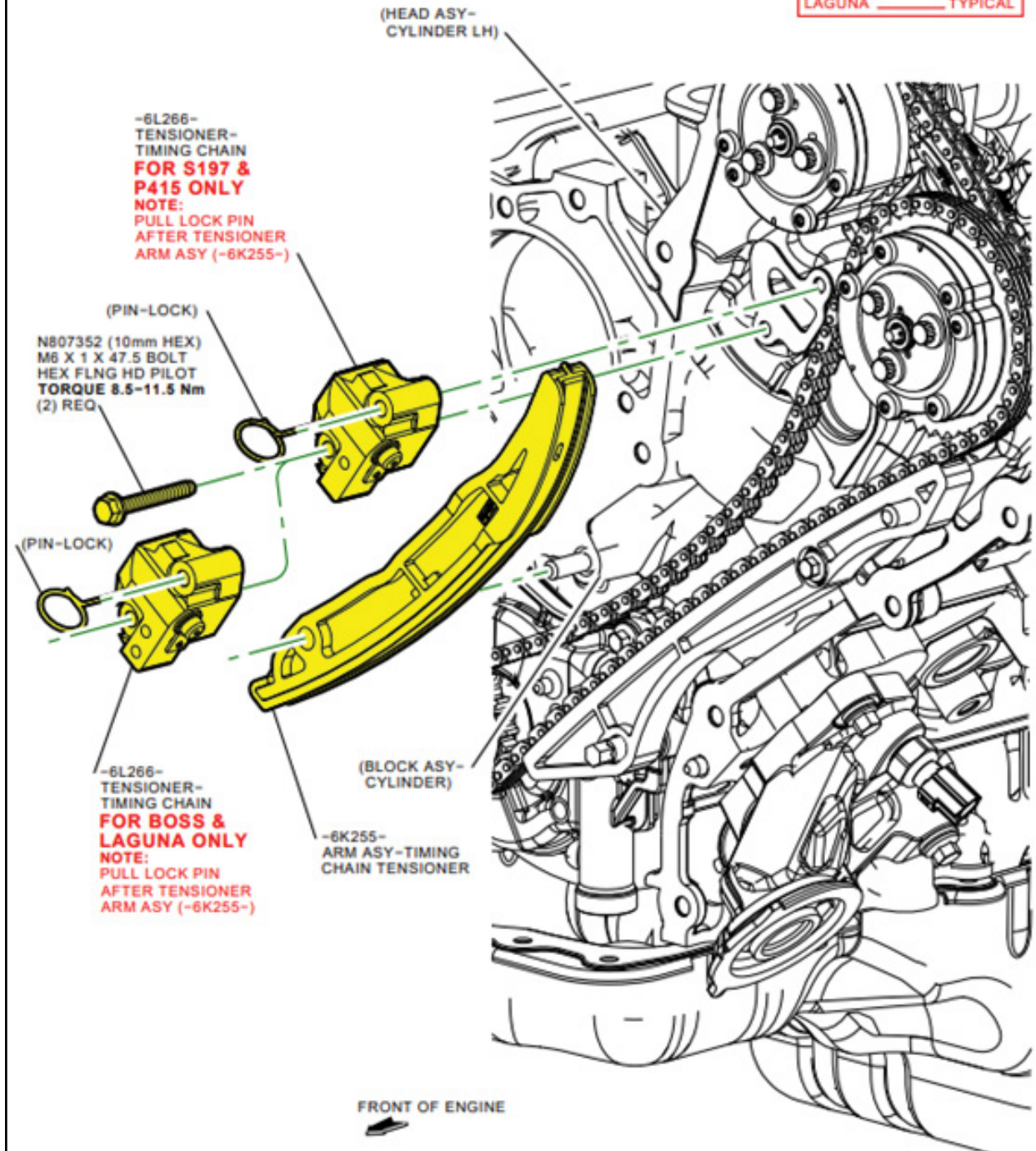

Ford Factory Shop Manual purchase options www.motorcraftservice.com



FORD PERFORMANCE

M-6004-A5015
2015-2017 Mustang 5.0L
Chain-drive kit

NO PART OF THIS DOCUMENT MAY BE REPRODUCED WITHOUT PRIOR AGREEMENT AND WRITTEN PERMISSION OF FORD PERFORMANCE PARTS

RH (Pass side) camshaft neutral position

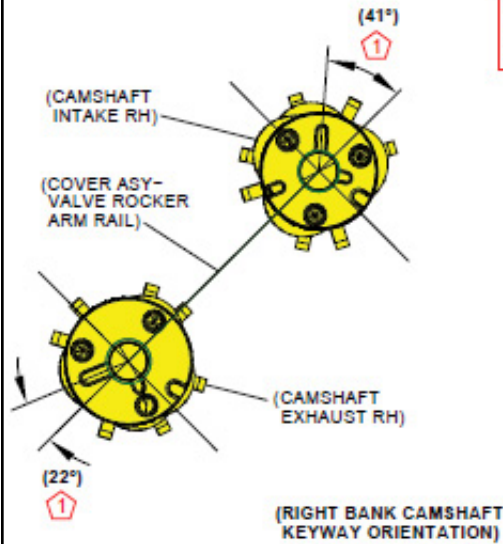

NOTE:
CRANKSHAFT KEYWAY MUST BE CLOCKED AT (12:00 POSITION).
CAMSHAFT MUST BE CLOCKED RELATIVE TO CAM COVER RAIL AS SHOWN,
PRIOR TO CAM DRIVE COMPONENTS RUNDOWN AND TIGHTENING.

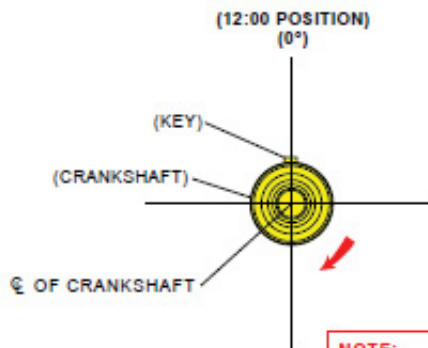

NOTE:
CRANKSHAFT MUST BE
ROTATED CLOCKWISE ONLY

FRONT VIEW

NOTE:
PRIOR TO RH CAMSHAFT INSTALLATION, ROTATE CRANKSHAFT 360° FROM POSITION FOR LH CAMSHAFT
INSTALLATION (SHEET 21B). THEN, WITH ADDITIONAL ROTATION, CRANKSHAFT KEYWAY MUST BE ORIENTED
AT 12:00 POSITION AS SHOWN. CAMSHAFTS MUST BE CLOCKED RELATIVE TO CAM COVER RAIL AS
SHOWN PRIOR TO CAM BEARING CAP INSTALLATION.

① REPRESENTS APPROXIMATE CAMSHAFT KEYWAY POSITIONS WHEN CAMSHAFTS ARE IN NEUTRAL POSITION SHOWN.



FORD PERFORMANCE

M-6004-A5015
2015-2017 Mustang 5.0L
Chain-drive kit

NO PART OF THIS DOCUMENT MAY BE REPRODUCED WITHOUT PRIOR AGREEMENT AND WRITTEN PERMISSION OF FORD PERFORMANCE PARTS

NOTE: Do not remove the secondary timing chain tensioner shipping clip, until instructed to do so.

NOTE: The secondary timing chain tensioner and shoe are of a new design. The secondary timing chain tensioner is shorter than the previous design and does not extend through the bottom of the camshaft mega cap. The new design shoe has tabs that contact the front of the mega cap when installed.

Apply clean engine oil to the secondary timing chain tensioner O-ring seals and mega cap bore.

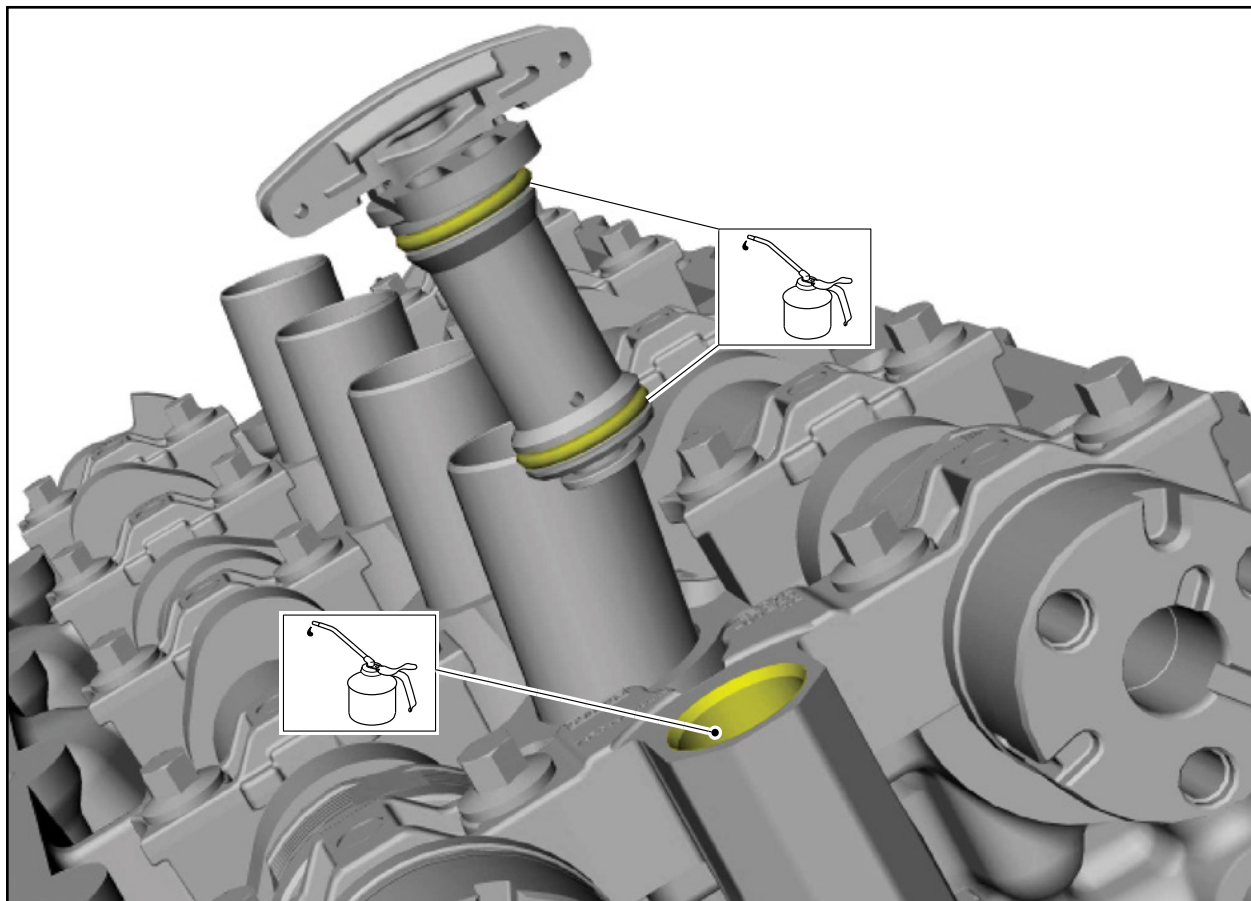

Ford Factory Shop Manual purchase options www.motorcraftservice.com



FORD PERFORMANCE

M-6004-A5015
2015-2017 Mustang 5.0L
Chain-drive kit

NO PART OF THIS DOCUMENT MAY BE REPRODUCED WITHOUT PRIOR AGREEMENT AND WRITTEN PERMISSION OF FORD PERFORMANCE PARTS

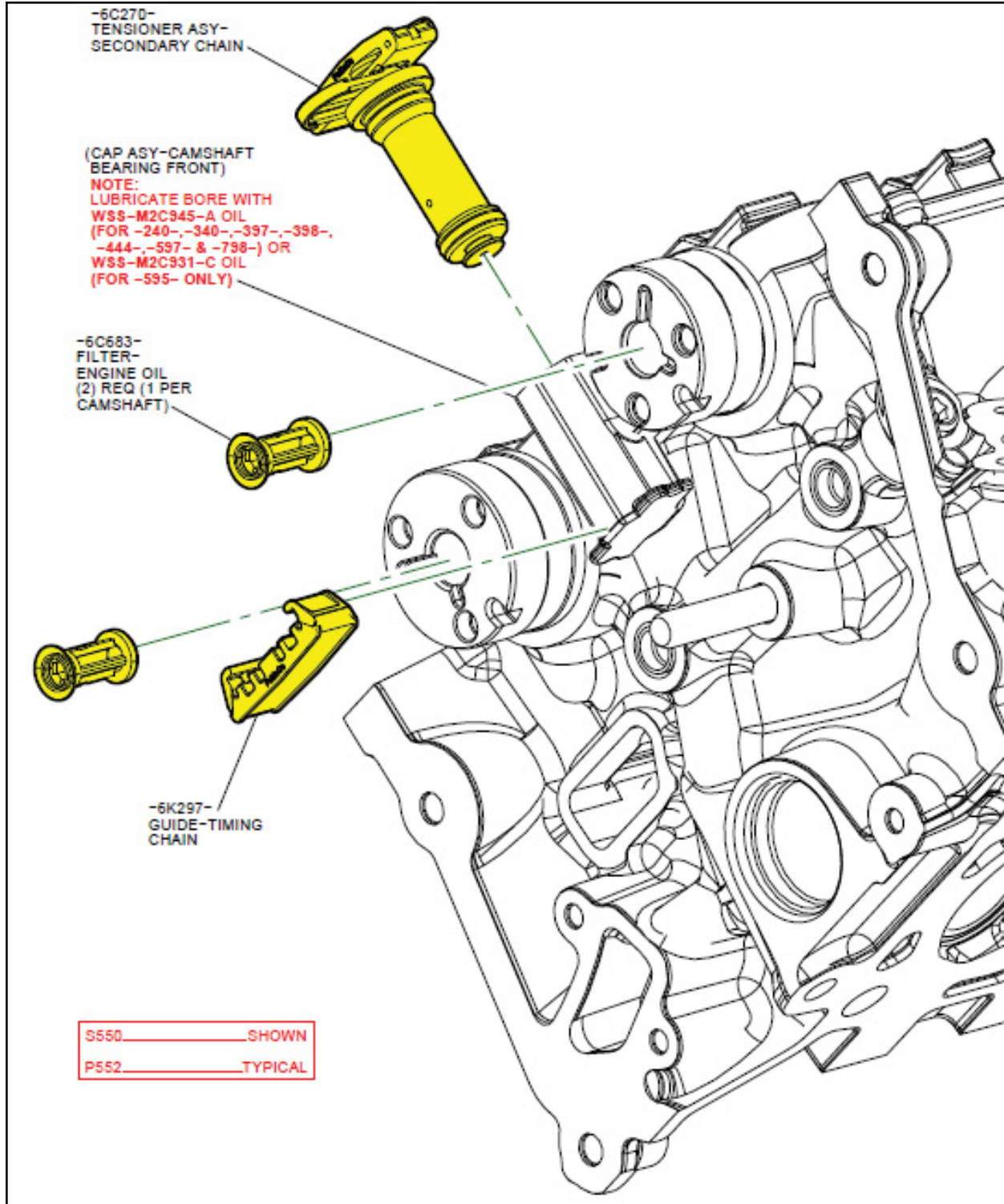

Ford Factory Shop Manual purchase options www.motorcraftservice.com



FORD PERFORMANCE

M-6004-A5015
2015-2017 Mustang 5.0L
Chain-drive kit

NO PART OF THIS DOCUMENT MAY BE REPRODUCED WITHOUT PRIOR AGREEMENT AND WRITTEN PERMISSION OF FORD PERFORMANCE PARTS

Install the secondary timing chain tensioner by pushing it down all the way until a snap is heard and the tensioner is seated all the way down the mega cap bore.

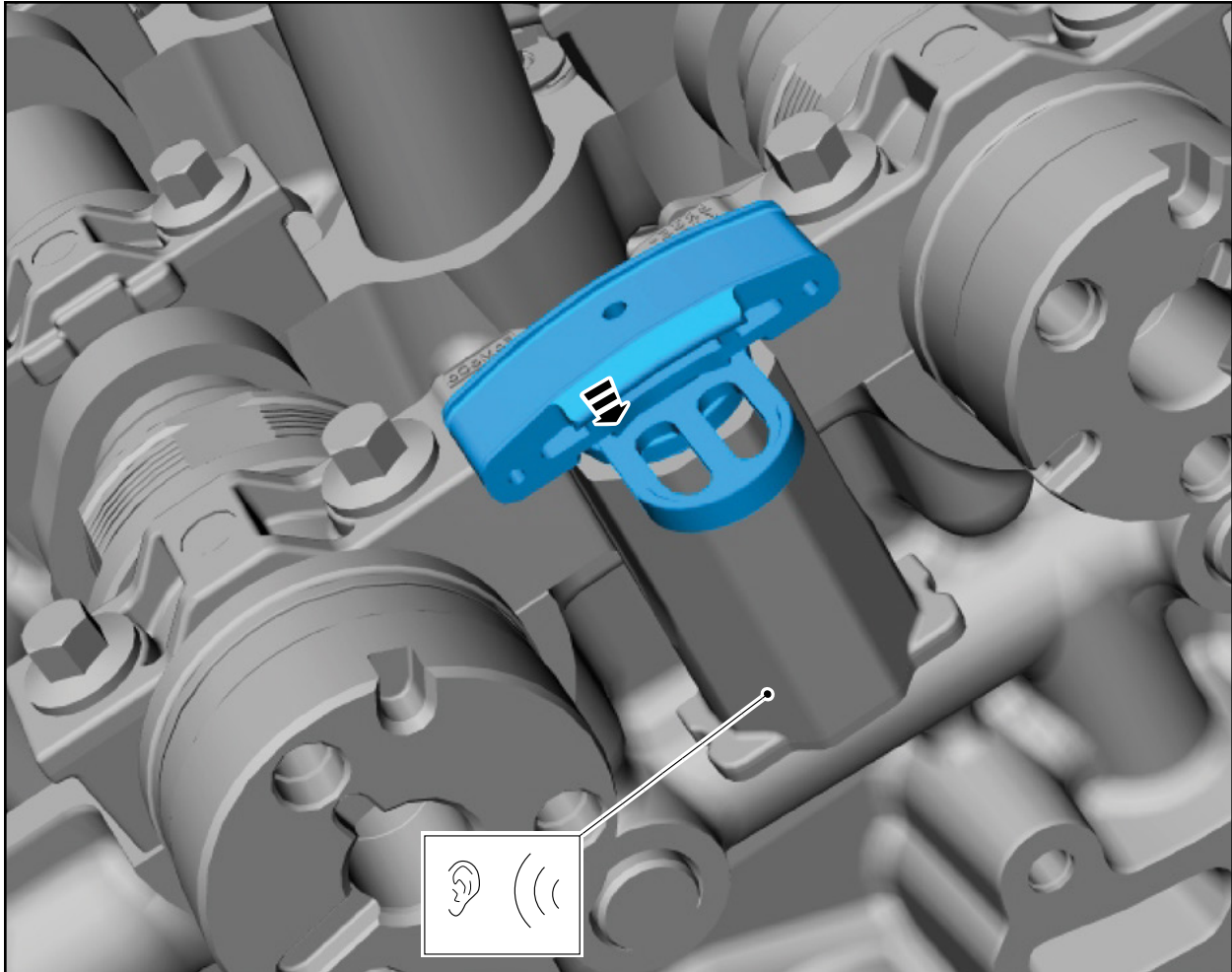

Ford Factory Shop Manual purchase options www.motorcraftservice.com



FORD PERFORMANCE

M-6004-A5015
2015-2017 Mustang 5.0L
Chain-drive kit

NO PART OF THIS DOCUMENT MAY BE REPRODUCED WITHOUT PRIOR AGREEMENT AND WRITTEN PERMISSION OF
FORD PERFORMANCE PARTS

Install the secondary timing chain tensioner shoe.

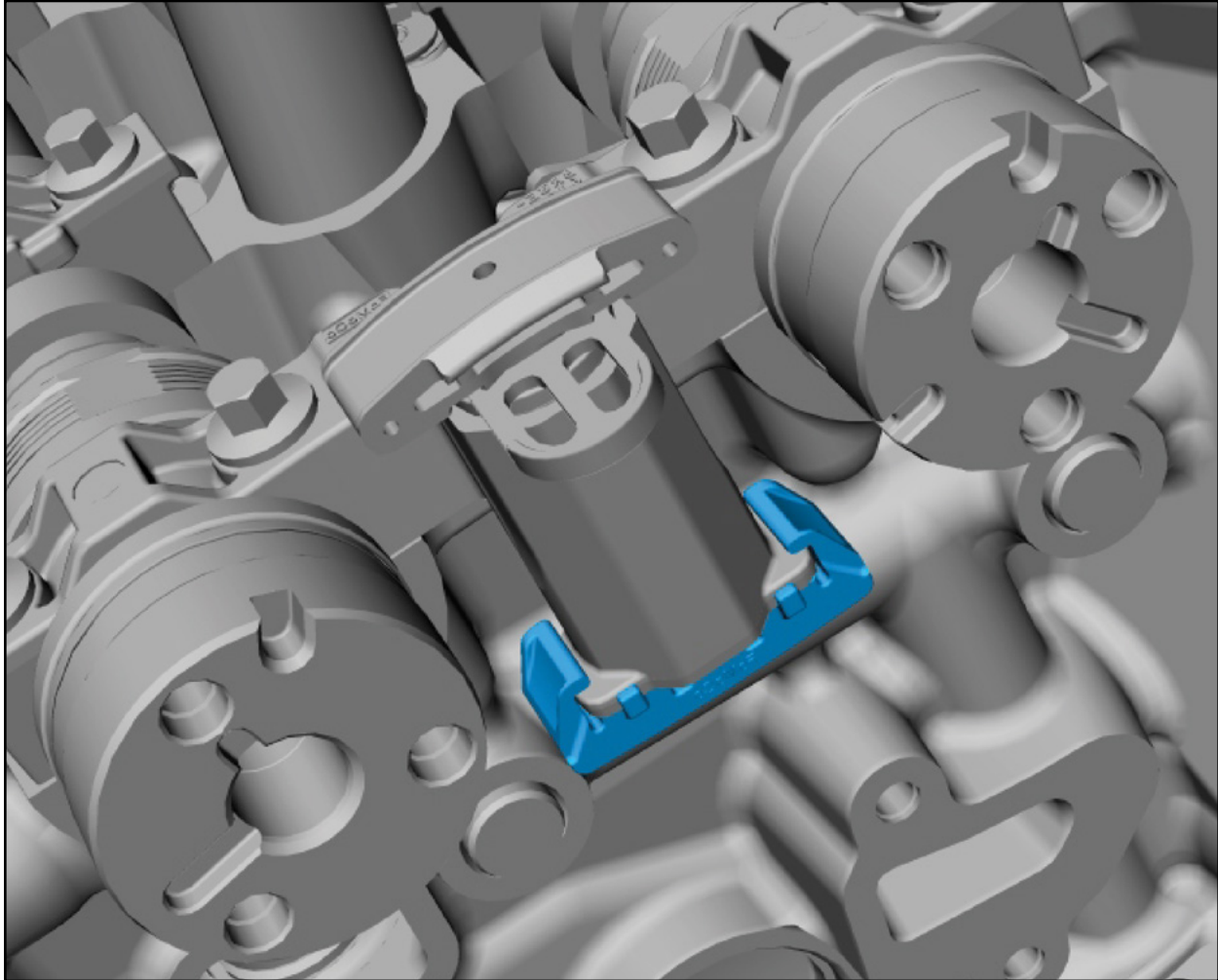

Ford Factory Shop Manual purchase options www.motorcraftservice.com



FORD PERFORMANCE

M-6004-A5015 2015-2017 Mustang 5.0L Chain-drive kit

NO PART OF THIS DOCUMENT MAY BE REPRODUCED WITHOUT PRIOR AGREEMENT AND WRITTEN PERMISSION OF FORD PERFORMANCE PARTS

NOTE:
PRE-ASSEMBLE SECONDARY CHAIN TO INTAKE & EXHAUST VCT UNITS. MARKED LINK PLATES LINE UP WITH TIMING MARKS ON ON BOTH INTAKE & EXHAUST VCT UNITS. ALIGN AS SHOWN IN VIEW A.

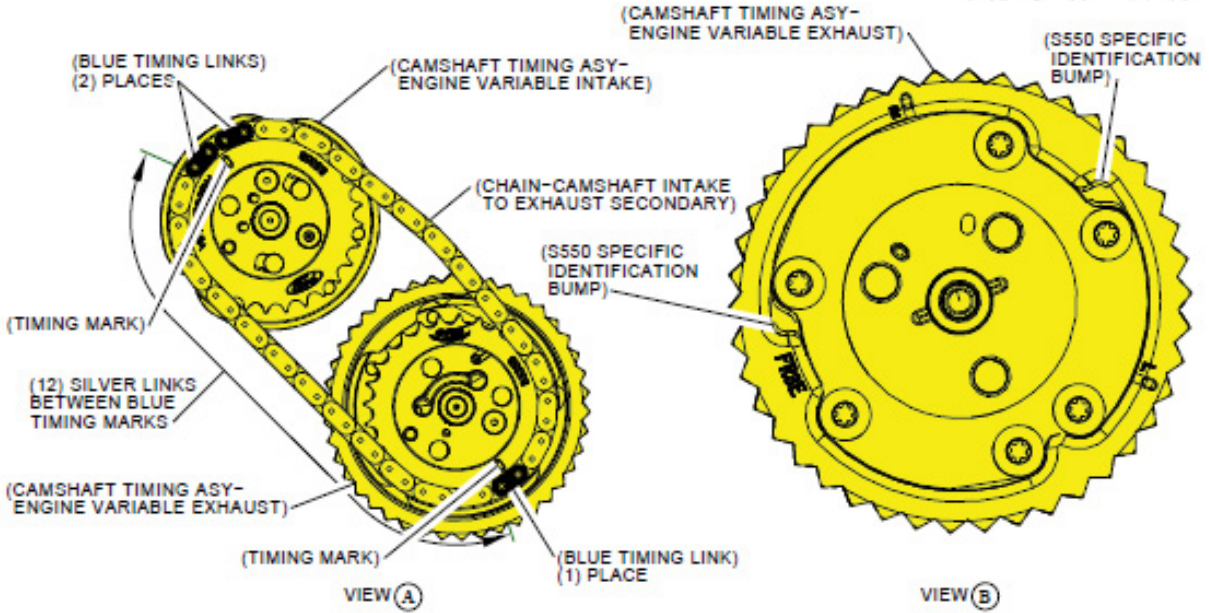
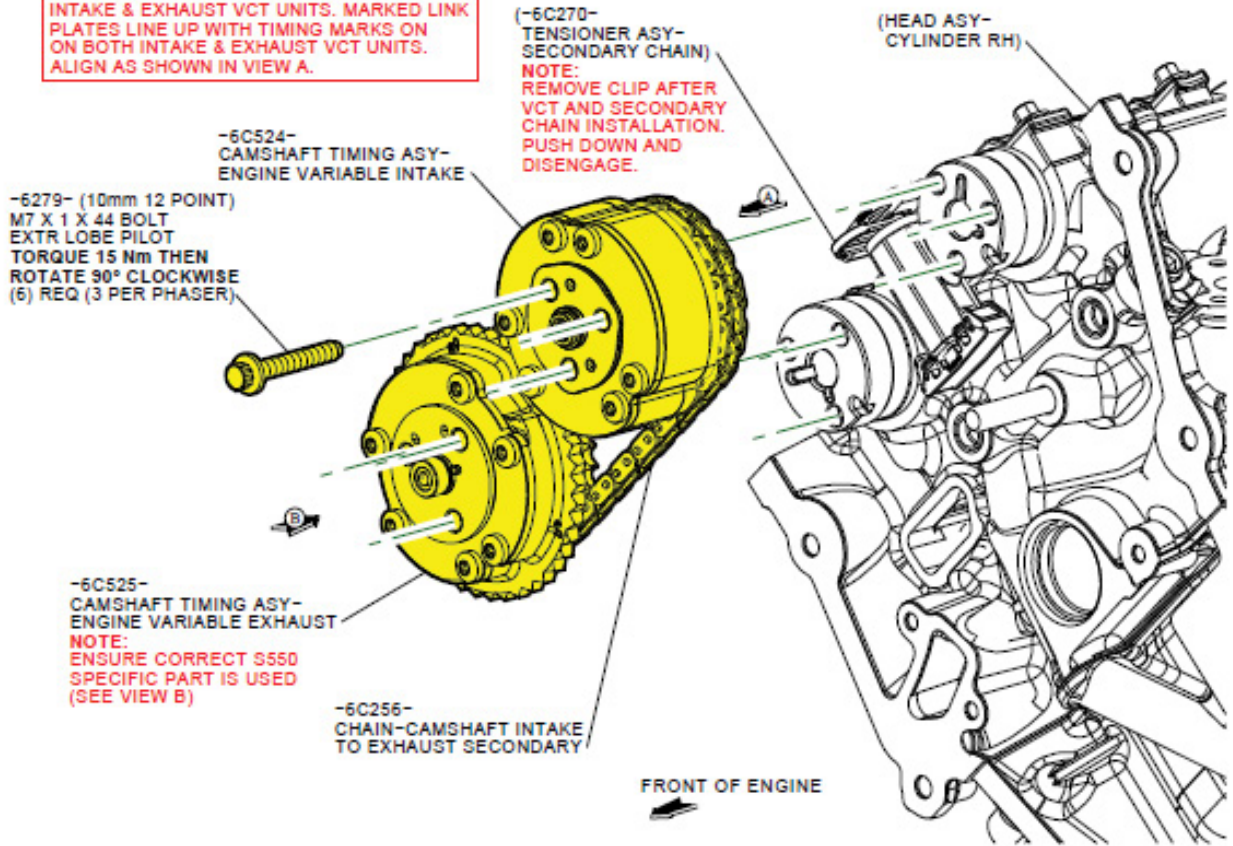

Ford Factory Shop Manual purchase options www.motorcraftservice.com



FORD PERFORMANCE

M-6004-A5015
2015-2017 Mustang 5.0L
Chain-drive kit

NO PART OF THIS DOCUMENT MAY BE REPRODUCED WITHOUT PRIOR AGREEMENT AND WRITTEN PERMISSION OF FORD PERFORMANCE PARTS

Remove and discard the secondary timing chain tensioner shipping clip.

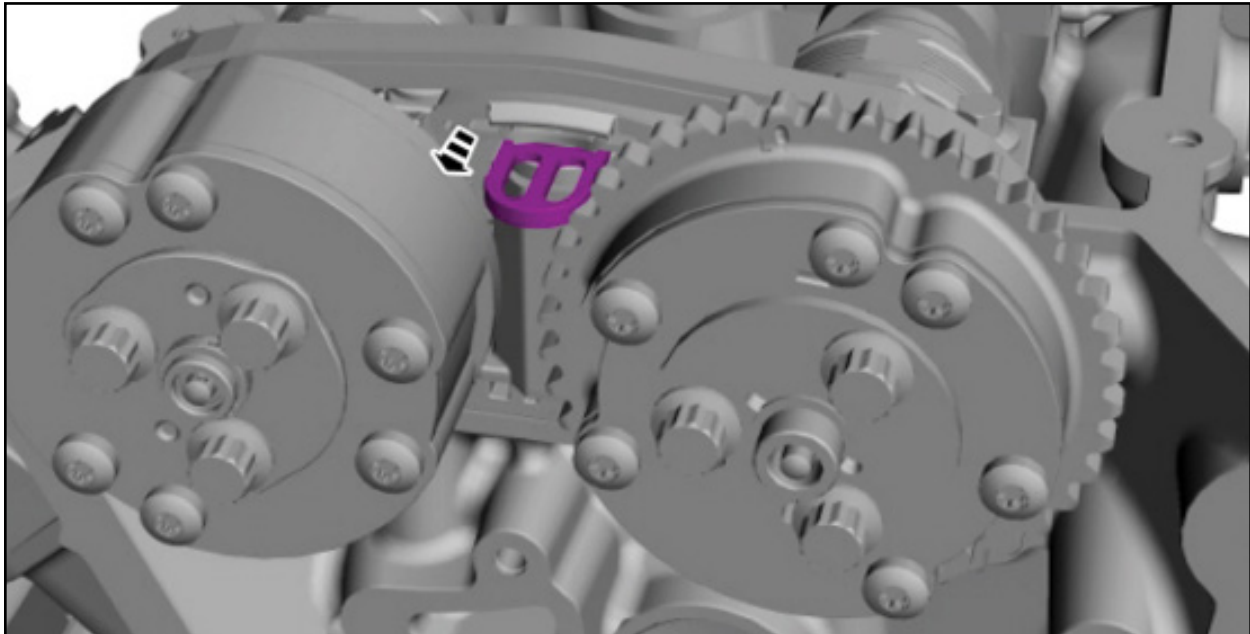

Activate the secondary timing chain tensioner by pressing down on the secondary timing chain and tensioner top shoe until it bottoms out, let go of the tensioner and it will spring up putting tension on the chain.

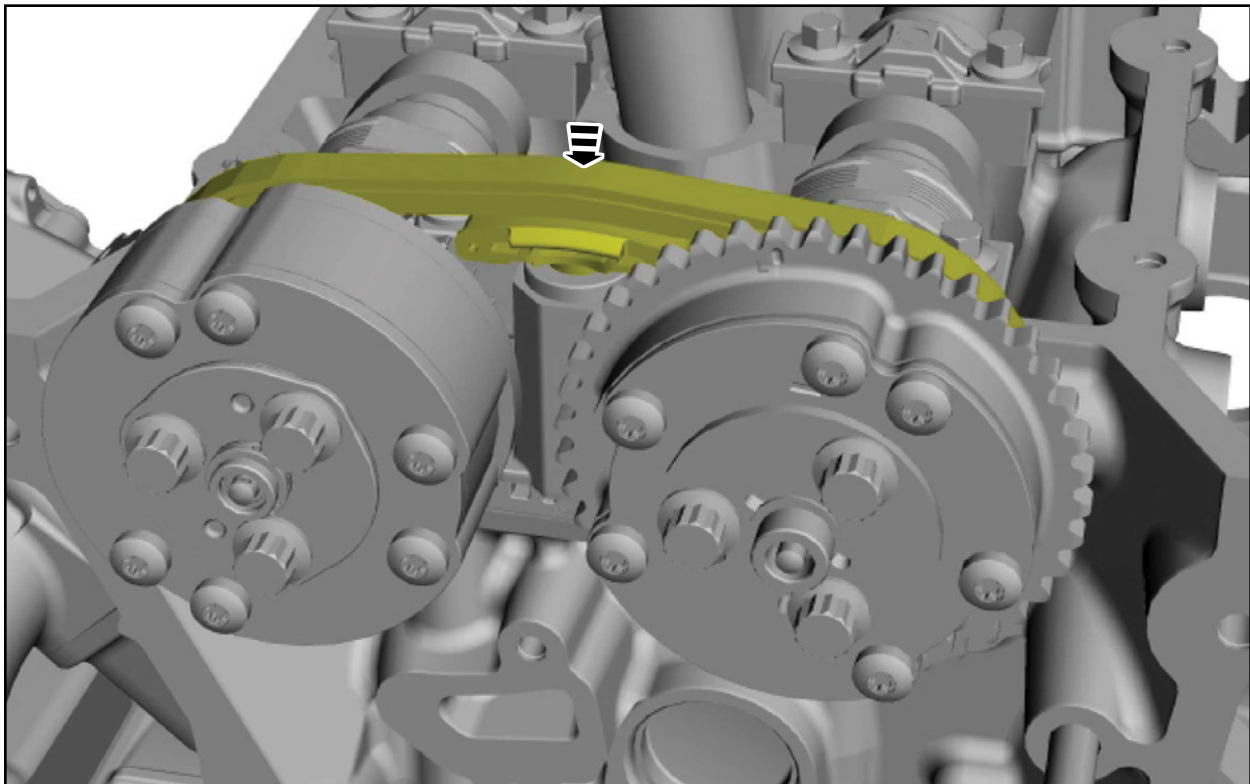

Ford Factory Shop Manual purchase options www.motorcraftservice.com



FORD PERFORMANCE

M-6004-A5015
2015-2017 Mustang 5.0L
Chain-drive kit

NO PART OF THIS DOCUMENT MAY BE REPRODUCED WITHOUT PRIOR AGREEMENT AND WRITTEN PERMISSION OF FORD PERFORMANCE PARTS

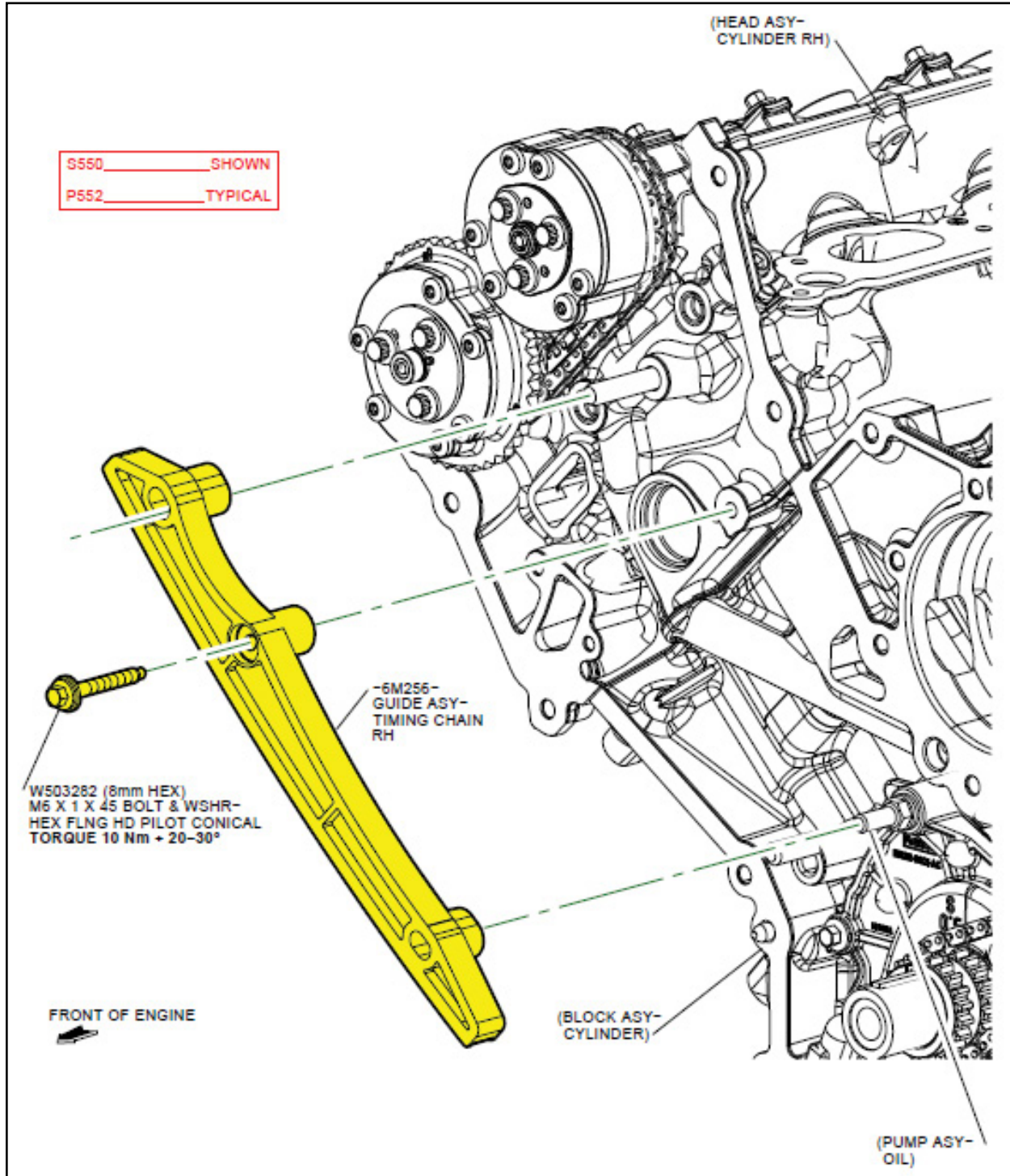

Ford Factory Shop Manual purchase options www.motorcraftservice.com



FORD PERFORMANCE

M-6004-A5015
2015-2017 Mustang 5.0L
Chain-drive kit

NO PART OF THIS DOCUMENT MAY BE REPRODUCED WITHOUT PRIOR AGREEMENT AND WRITTEN PERMISSION OF FORD PERFORMANCE PARTS

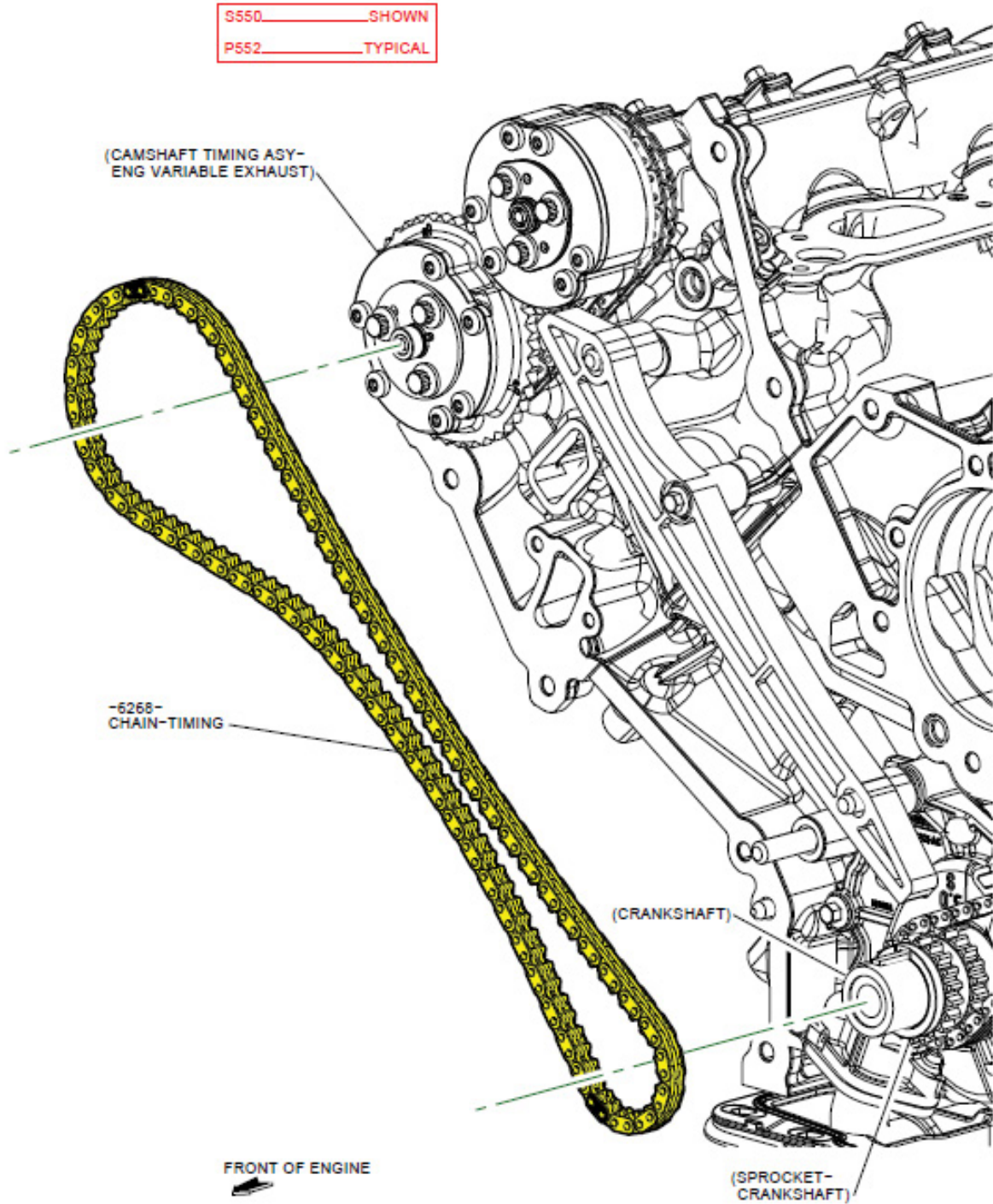

Ford Factory Shop Manual purchase options www.motorcraftservice.com



FORD PERFORMANCE

M-6004-A5015
2015-2017 Mustang 5.0L
Chain-drive kit

NO PART OF THIS DOCUMENT MAY BE REPRODUCED WITHOUT PRIOR AGREEMENT AND WRITTEN PERMISSION OF FORD PERFORMANCE PARTS

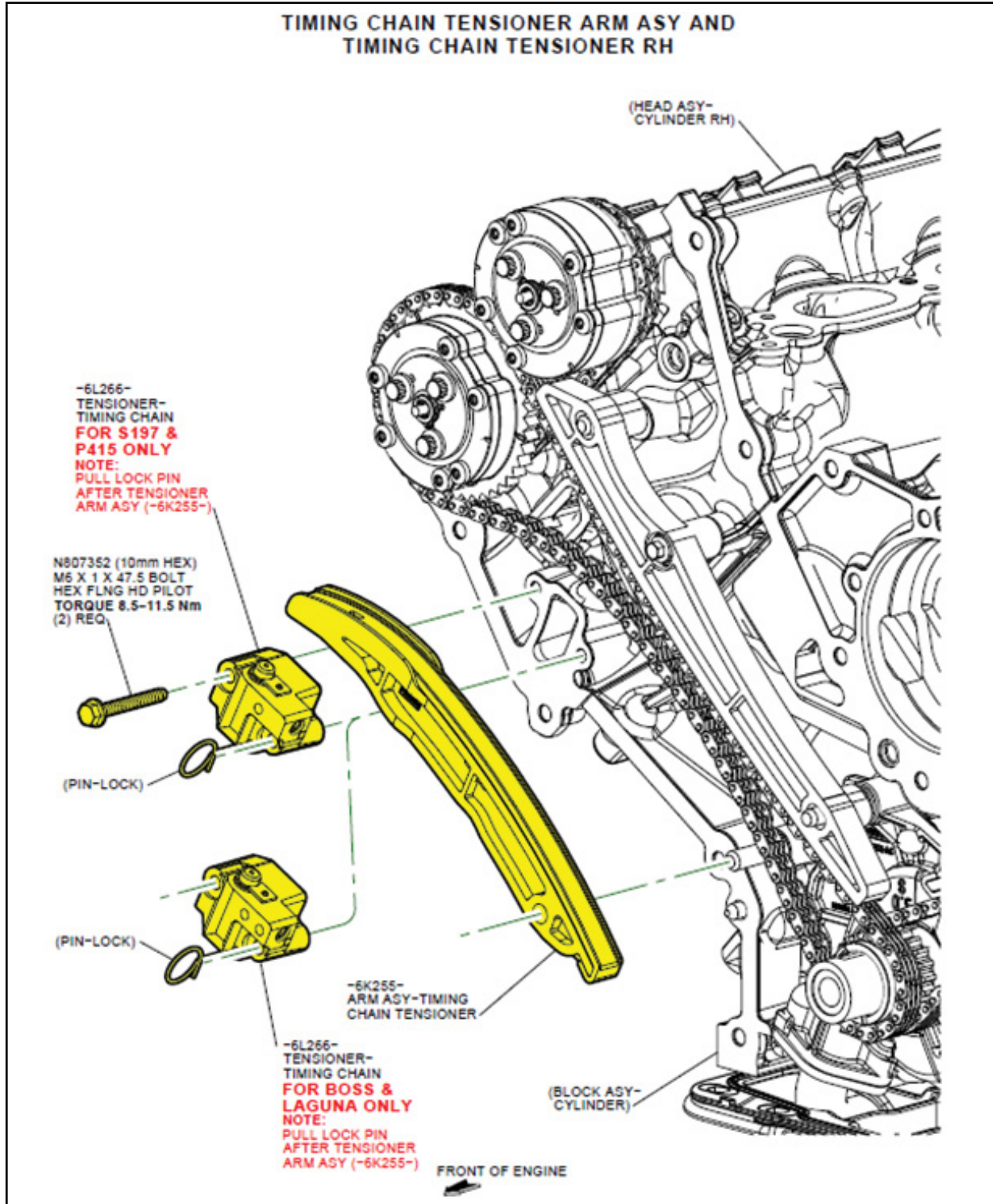

Ford Factory Shop Manual purchase options www.motorcraftservice.com



FORD PERFORMANCE

M-6004-A5015 2015-2017 Mustang 5.0L Chain-drive kit

NO PART OF THIS DOCUMENT MAY BE REPRODUCED WITHOUT PRIOR AGREEMENT AND WRITTEN PERMISSION OF FORD PERFORMANCE PARTS

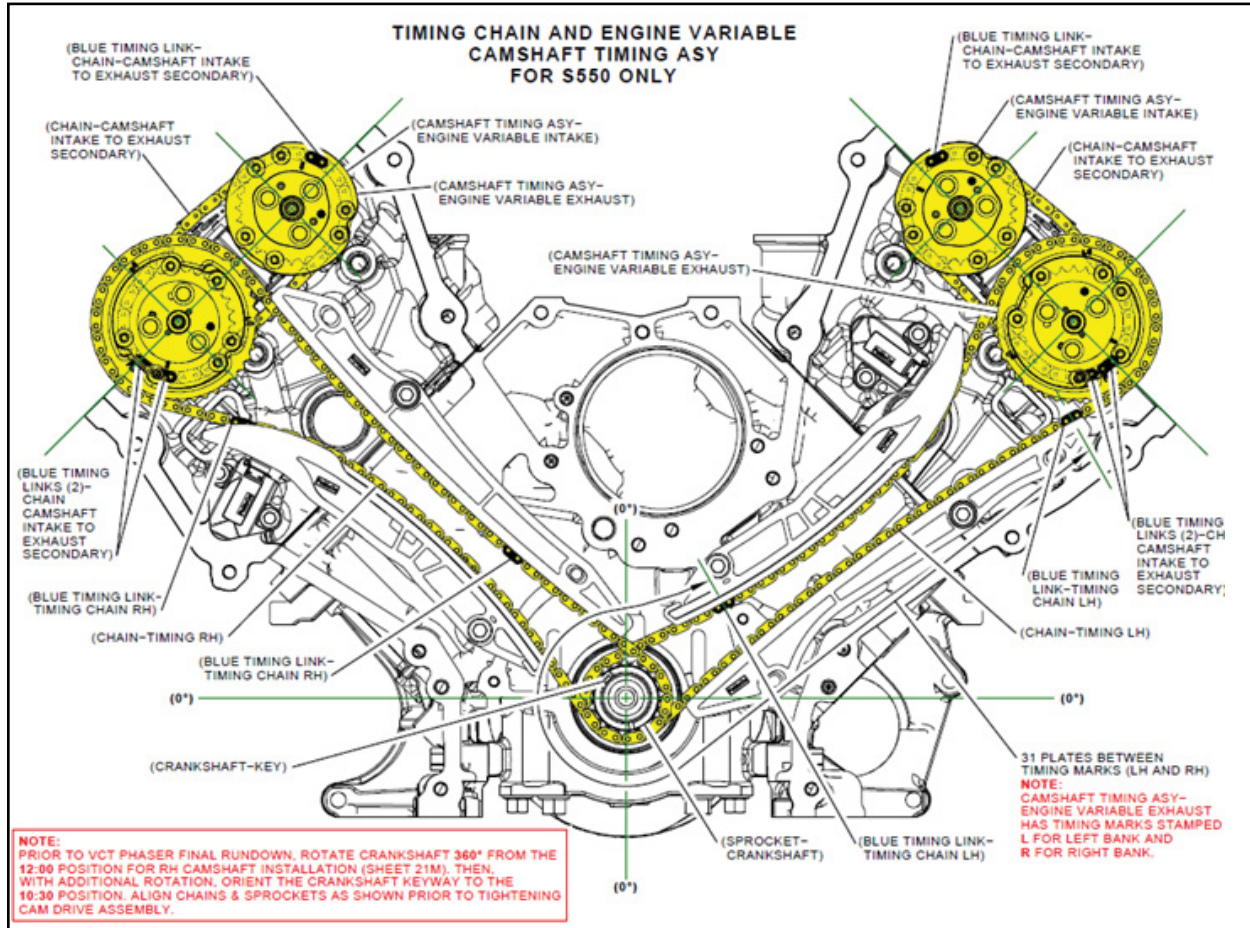

Ford Factory Shop Manual purchase options www.motorcraftservice.com