



M-6004-A5018
2018-2023 Mustang 5.0L
Chain-drive kit

NO PART OF THIS DOCUMENT MAY BE REPRODUCED WITHOUT PRIOR AGREEMENT AND WRITTEN PERMISSION OF
FORD PERFORMANCE PARTS

PRIOR TO INSTALLATION READ THESE INSTRUCTION COMPLETELY
For questions, Call the FORD PERFORMANCE Techline 1-800-367-3788

Please visit <https://www.performanceparts.ford.com> for warranty information

Part #	Description	Qty
9L8Z-6C683-A	VCT/camshaft filter	2
BR3Z-6A340-A	Damper bolt	1
BR3Z-6268-A	Secondary timing chain	2
FR3Z-6268-A	Primary timing chain	2
BR3Z-6279-A	VCT phaser bolt	6
FR3Z-6256-C	Intake VCT sprocket	2
JL3Z-6L266-C	Primary chain tensioner	2
JL3Z-6B274-B	Chain guide	1
JL3Z-6K255-A	Tensioner arm	2
JL3Z-6M256-A	Chain guide	1
JR3Z-6C525-A	Exhaust VCT sprocket	2
JR3Z-6279-A	Exhaust phaser bolt	2
KR3Z-6306-B	Crank sprocket	1
ML3Z-6K254-A	Secondary chain tensioner	2
ML3Z-6K297-A	Secondary tensioner guide	2
N806183-S437	Oil pump bolt	2
N807033-S439	Damper bolt washer	1
W503282-S437	Chain guide bolt	2
W701501-S	Dowel	1
W714251-S300	Oil pump stud bolt	1
W714252-S300	Oil pump stud bolt	1
W714258-S300	Dowel	3
W718243-S437	Primary tensioner bolt	4

Ford Factory Shop Manual purchase options www.motorcraftservice.com



FORD PERFORMANCE

M-6004-A5018 2018-2023 Mustang 5.0L Chain-drive kit

NO PART OF THIS DOCUMENT MAY BE REPRODUCED WITHOUT PRIOR AGREEMENT AND WRITTEN PERMISSION OF FORD PERFORMANCE PARTS

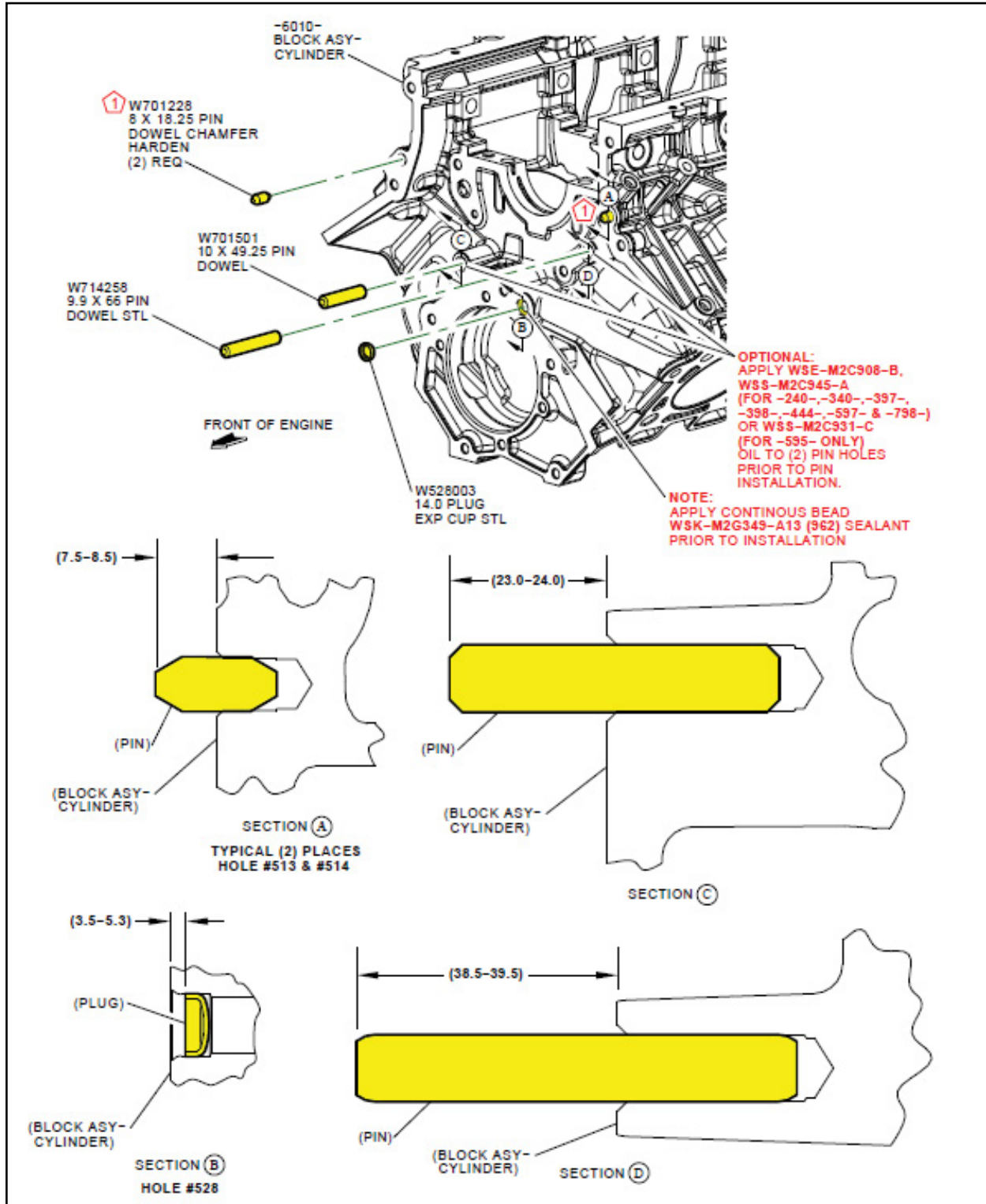

Ford Factory Shop Manual purchase options www.motorcraftservice.com



FORD PERFORMANCE

M-6004-A5018 2018-2023 Mustang 5.0L Chain-drive kit

NO PART OF THIS DOCUMENT MAY BE REPRODUCED WITHOUT PRIOR AGREEMENT AND WRITTEN PERMISSION OF FORD PERFORMANCE PARTS

NOTE:
BACKGROUND DETAIL NOT PICTORIALLY
ACCURATE FOR ALL APPLICATIONS

W714252 (9mm HEX)
M8 X 1.25 X 45 +
10 X 24 PIN & WASHER
HEX PILOT CONICAL
TORQUE 20 Nm THEN
ROTATE 55°- 65° CLOCKWISE

W714251 (13mm HEX)
M8 X 1.25 X 52 + 9 X 24 PIN & WSHR
HEX FLNG HD PILOT CONICAL
TORQUE 25 Nm THEN
ROTATE 70°- 80° CLOCKWISE

N806183 (8mm HEX)
M6 X 1 X 42.5 BOLT
HEX FLNG HD PILOT
TORQUE 10 Nm THEN
ROTATE 40°- 50° CLOCKWISE
(2) REQ

-6621-
PUMP ASY-OIL LESS
SCREEN & COVER

(CRANKSHAFT)

(BLOCK ASY-CYLINDER)

FRONT OF ENGINE

ASSEMBLY PROCEDURE

1. ROTATE INNER ROTOR OF OIL PUMP ASY (-6621-) TO ALIGN WITH FLATS ON CRANKSHAFT POST AND SLIP OIL PUMP OVER UNTIL SEATED AGAINST BLOCK.
NOTE:
PUMP MUST BE HELD AGAINST BLOCK UNTIL BOLTS ARE TORQUED.
2. ROTATE OIL PUMP ASY, ALIGN BOLT HOLES, INSTALL (4) FASTENERS AND SIMULTANEOUSLY TORQUE TO SPECIFICATION.
NOTE:
FOR PRODUCTION, ROTATION OF CRANKSHAFT DURING TORQUE PROCEDURE IS REQUIRED.

SINGLE WRENCH METHOD (SERVICE)

1. ROTATE INNER ROTOR OF OIL PUMP ASY TO ALIGN WITH FLATS ON CRANKSHAFT POST AND SLIP OIL PUMP OVER UNTIL SEATED AGAINST BLOCK.
NOTE:
PUMP MUST BE HELD AGAINST BLOCK UNTIL BOLTS ARE TORQUED.
2. ROTATE OIL PUMP ASY, ALIGN BOLT HOLES, INSTALL (4) FASTENERS.
3. TORQUE FASTENERS 0 Nm.
4. TORQUE M8 FASTENER W714251 25 Nm, M8 FASTENER W714252 20 Nm AND M6 FASTENERS N806183 10 Nm.
5. ROTATE M8 FASTENER W714251 70°- 80° CLOCKWISE, ROTATE M8 FASTENER W714252 55°- 65° CLOCKWISE AND M6 FASTENERS N806183 40°- 50° CLOCKWISE.

Ford Factory Shop Manual purchase options www.motorcraftservice.com



FORD PERFORMANCE

M-6004-A5018
2018-2023 Mustang 5.0L
Chain-drive kit

NO PART OF THIS DOCUMENT MAY BE REPRODUCED WITHOUT PRIOR AGREEMENT AND WRITTEN PERMISSION OF FORD PERFORMANCE PARTS

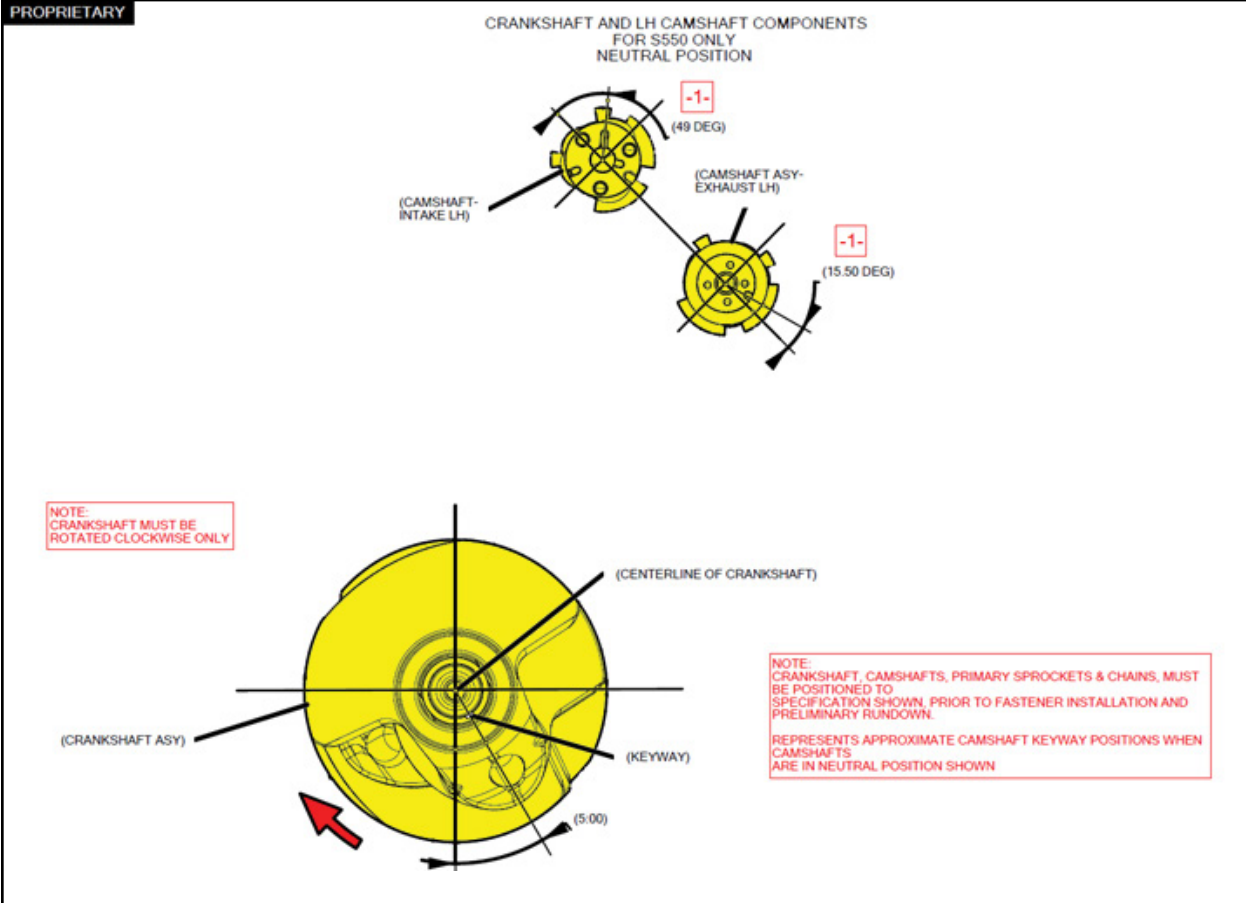

Ford Factory Shop Manual purchase options www.motorcraftservice.com



FORD PERFORMANCE

M-6004-A5018
2018-2023 Mustang 5.0L
Chain-drive kit

NO PART OF THIS DOCUMENT MAY BE REPRODUCED WITHOUT PRIOR AGREEMENT AND WRITTEN PERMISSION OF FORD PERFORMANCE PARTS

NOTE: Do not remove the secondary timing chain tensioner shipping clip, until instructed to do so.

NOTE: The secondary timing chain tensioner and shoe are of a new design. The secondary timing chain tensioner is shorter than the previous design and does not extend through the bottom of the camshaft mega cap. The new design shoe has tabs that contact the front of the mega cap when installed.

Apply clean engine oil to the secondary timing chain tensioner O-ring seals and mega cap bore.

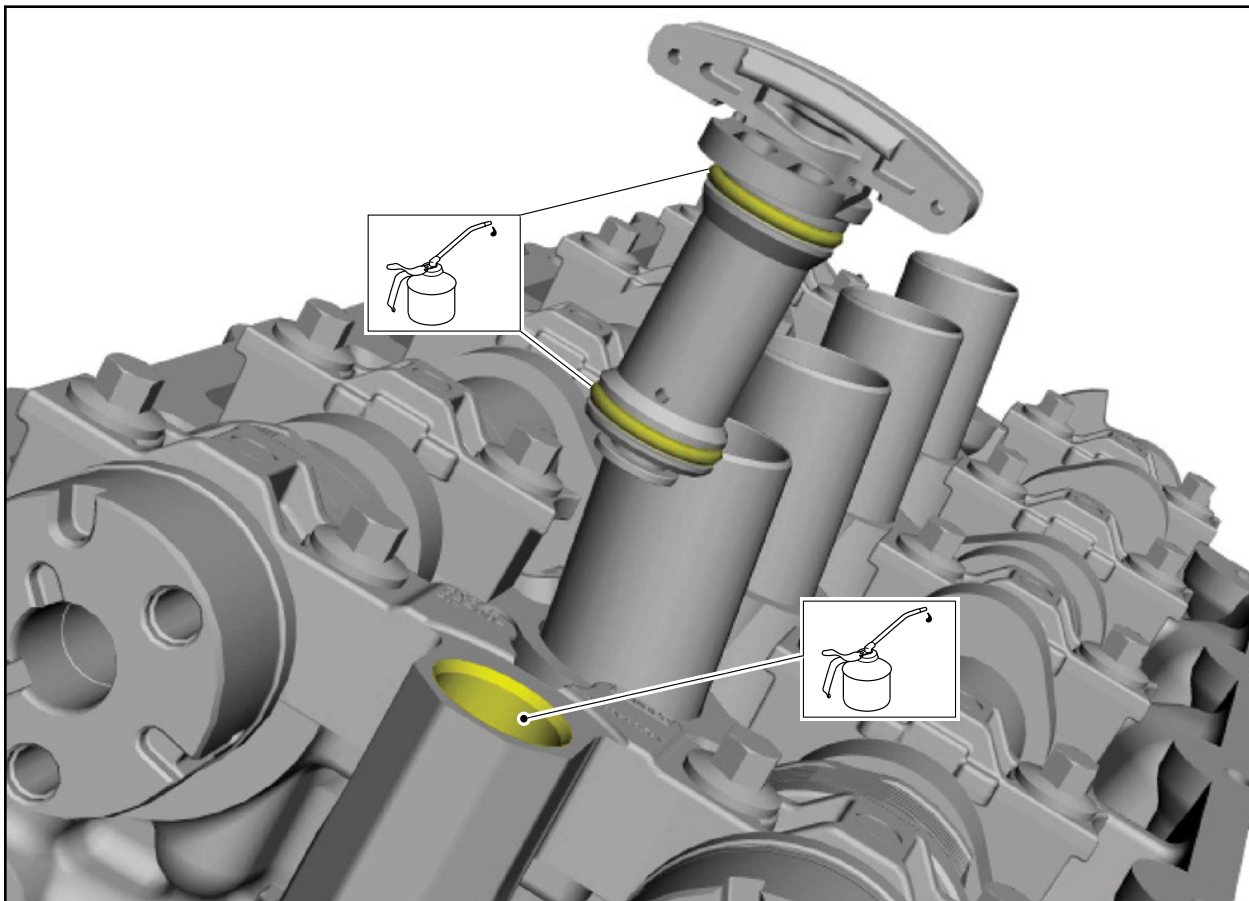

Ford Factory Shop Manual purchase options www.motorcraftservice.com



FORD PERFORMANCE

M-6004-A5018
2018-2023 Mustang 5.0L
Chain-drive kit

NO PART OF THIS DOCUMENT MAY BE REPRODUCED WITHOUT PRIOR AGREEMENT AND WRITTEN PERMISSION OF FORD PERFORMANCE PARTS

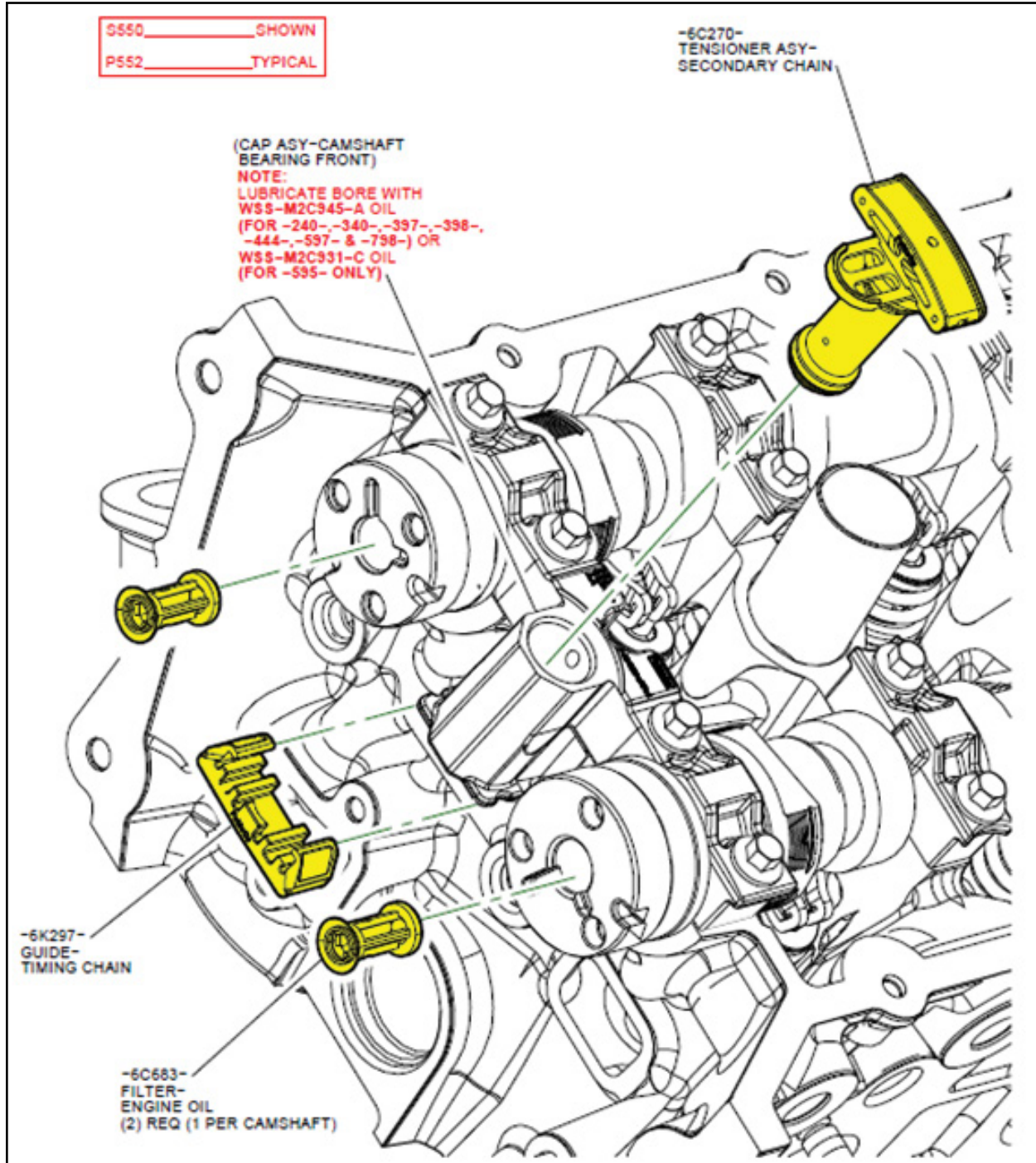

Ford Factory Shop Manual purchase options www.motorcraftservice.com



FORD PERFORMANCE

M-6004-A5018
2018-2023 Mustang 5.0L
Chain-drive kit

NO PART OF THIS DOCUMENT MAY BE REPRODUCED WITHOUT PRIOR AGREEMENT AND WRITTEN PERMISSION OF FORD PERFORMANCE PARTS

Install the secondary timing chain tensioner by pushing it down all the way until a snap is heard and the tensioner is seated all the way down the mega cap bore.

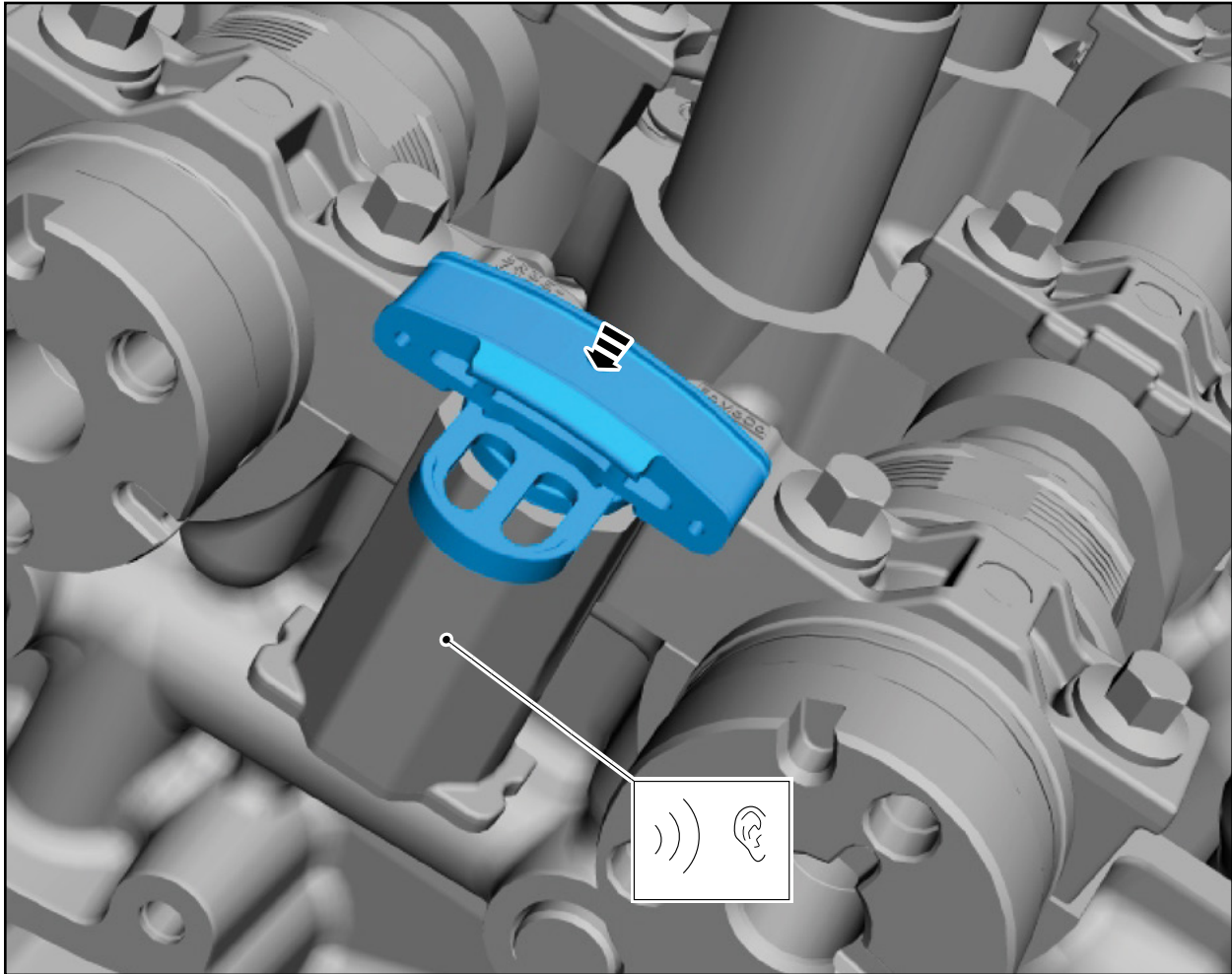

Ford Factory Shop Manual purchase options www.motorcraftservice.com



FORD PERFORMANCE

M-6004-A5018
2018-2023 Mustang 5.0L
Chain-drive kit

NO PART OF THIS DOCUMENT MAY BE REPRODUCED WITHOUT PRIOR AGREEMENT AND WRITTEN PERMISSION OF
FORD PERFORMANCE PARTS

Install the secondary timing chain tensioner shoe.

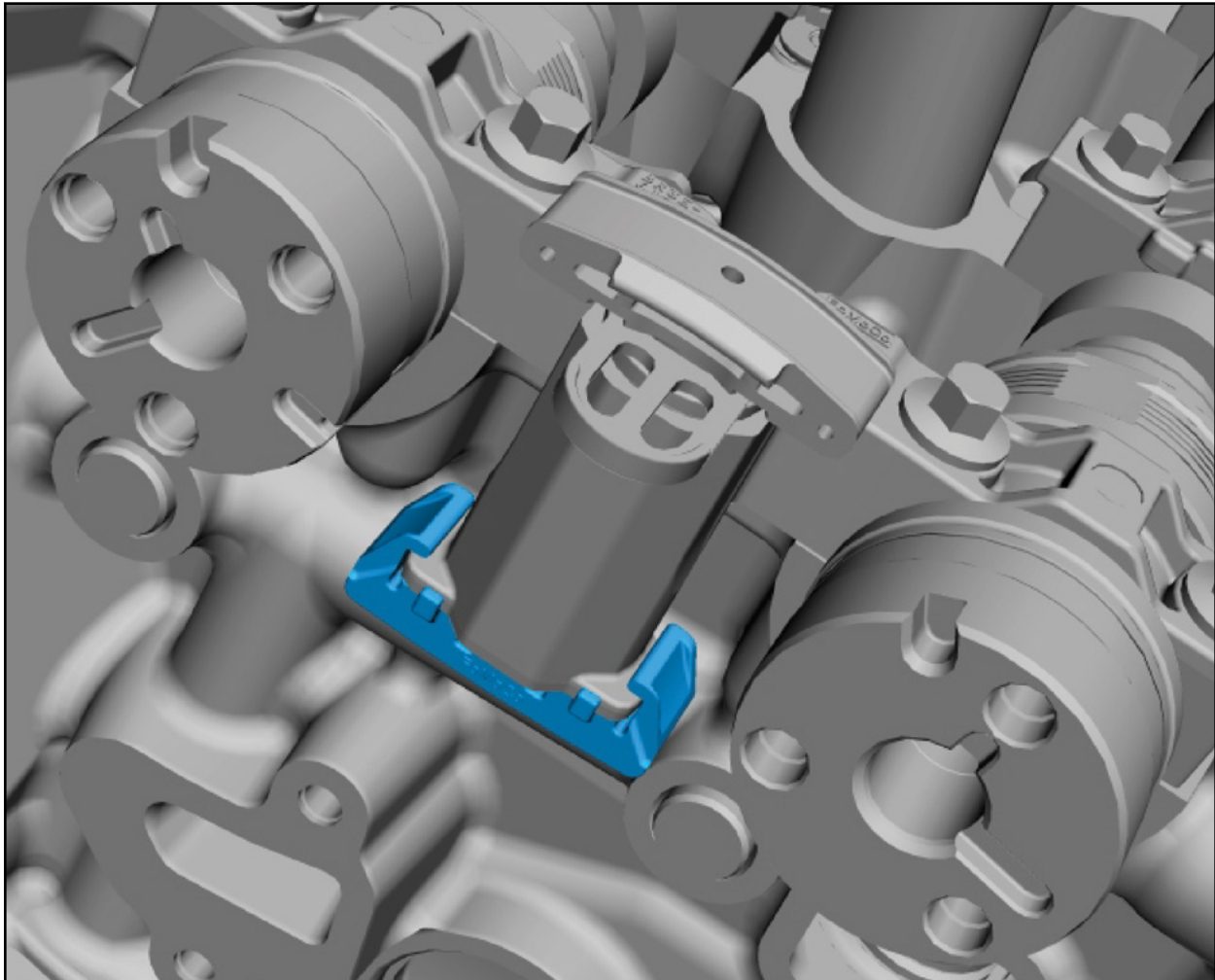

Ford Factory Shop Manual purchase options www.motorcraftservice.com



FORD PERFORMANCE

M-6004-A5018 2018-2023 Mustang 5.0L Chain-drive kit

NO PART OF THIS DOCUMENT MAY BE REPRODUCED WITHOUT PRIOR AGREEMENT AND WRITTEN PERMISSION OF FORD PERFORMANCE PARTS

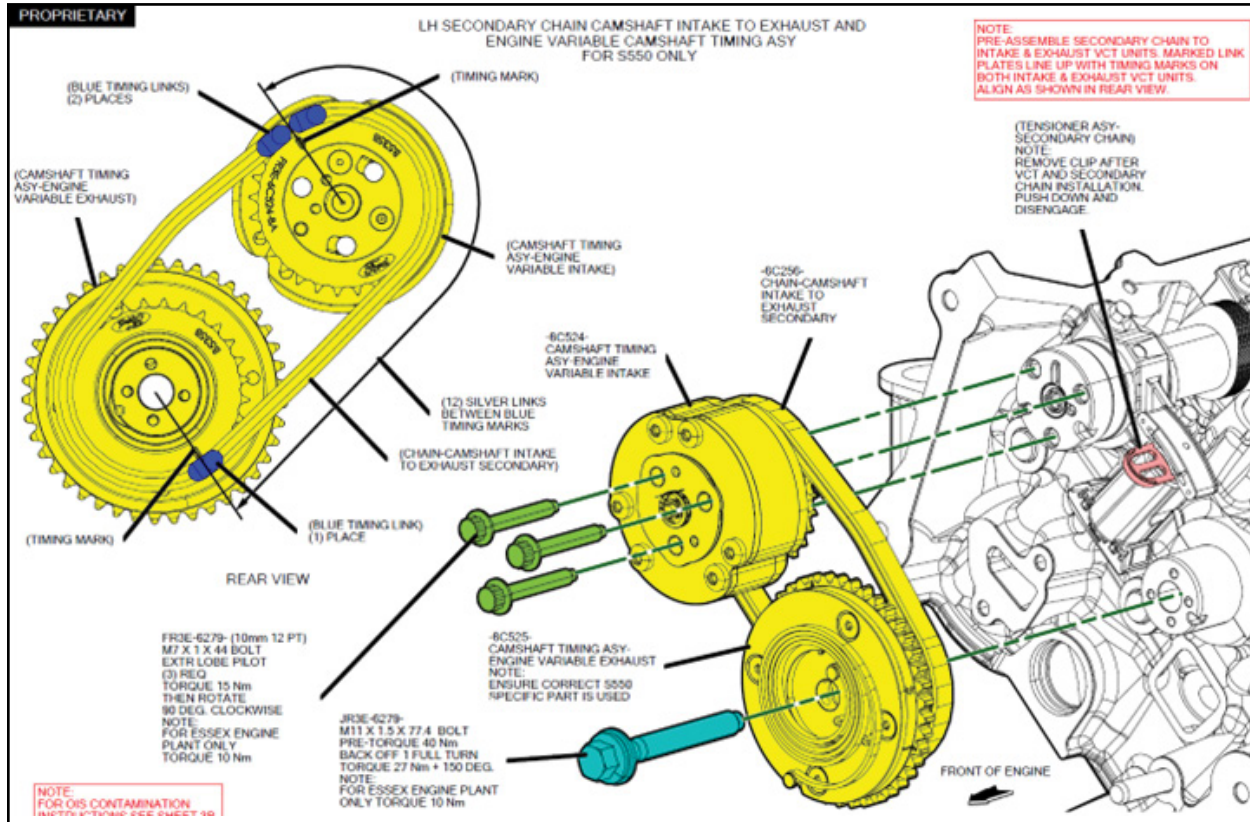

Ford Factory Shop Manual purchase options www.motorcraftservice.com



FORD PERFORMANCE

M-6004-A5018
2018-2023 Mustang 5.0L
Chain-drive kit

NO PART OF THIS DOCUMENT MAY BE REPRODUCED WITHOUT PRIOR AGREEMENT AND WRITTEN PERMISSION OF FORD PERFORMANCE PARTS

Remove and discard the secondary timing chain tensioner shipping clip.

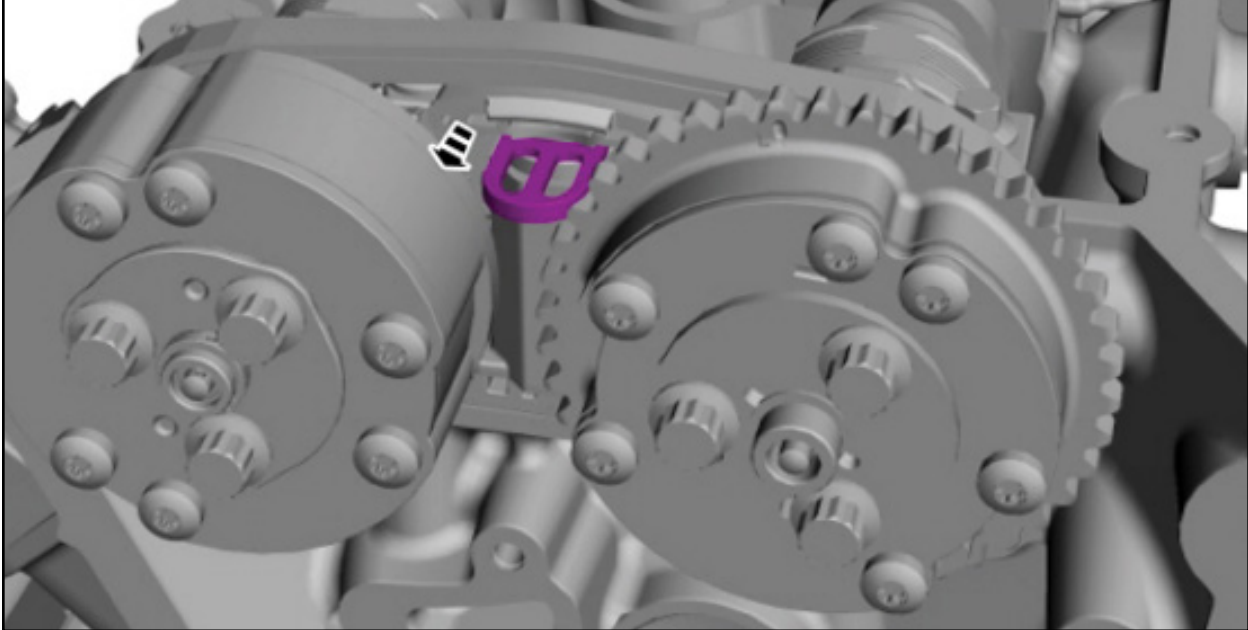

Activate the secondary timing chain tensioner by pressing down on the secondary timing chain and tensioner top shoe until it bottoms out, let go of the tensioner and it will spring up putting tension on the chain.

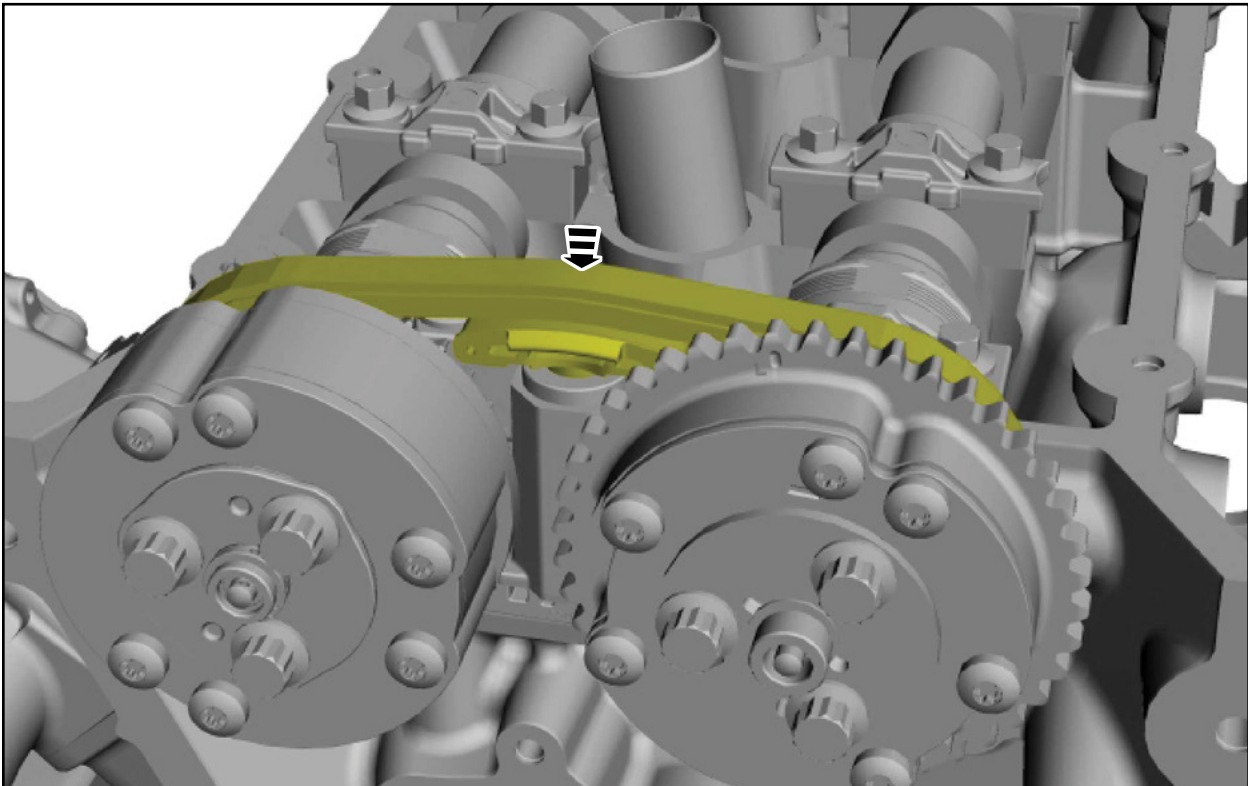

Ford Factory Shop Manual purchase options www.motorcraftservice.com



FORD PERFORMANCE

M-6004-A5018
2018-2023 Mustang 5.0L
Chain-drive kit

NO PART OF THIS DOCUMENT MAY BE REPRODUCED WITHOUT PRIOR AGREEMENT AND WRITTEN PERMISSION OF FORD PERFORMANCE PARTS

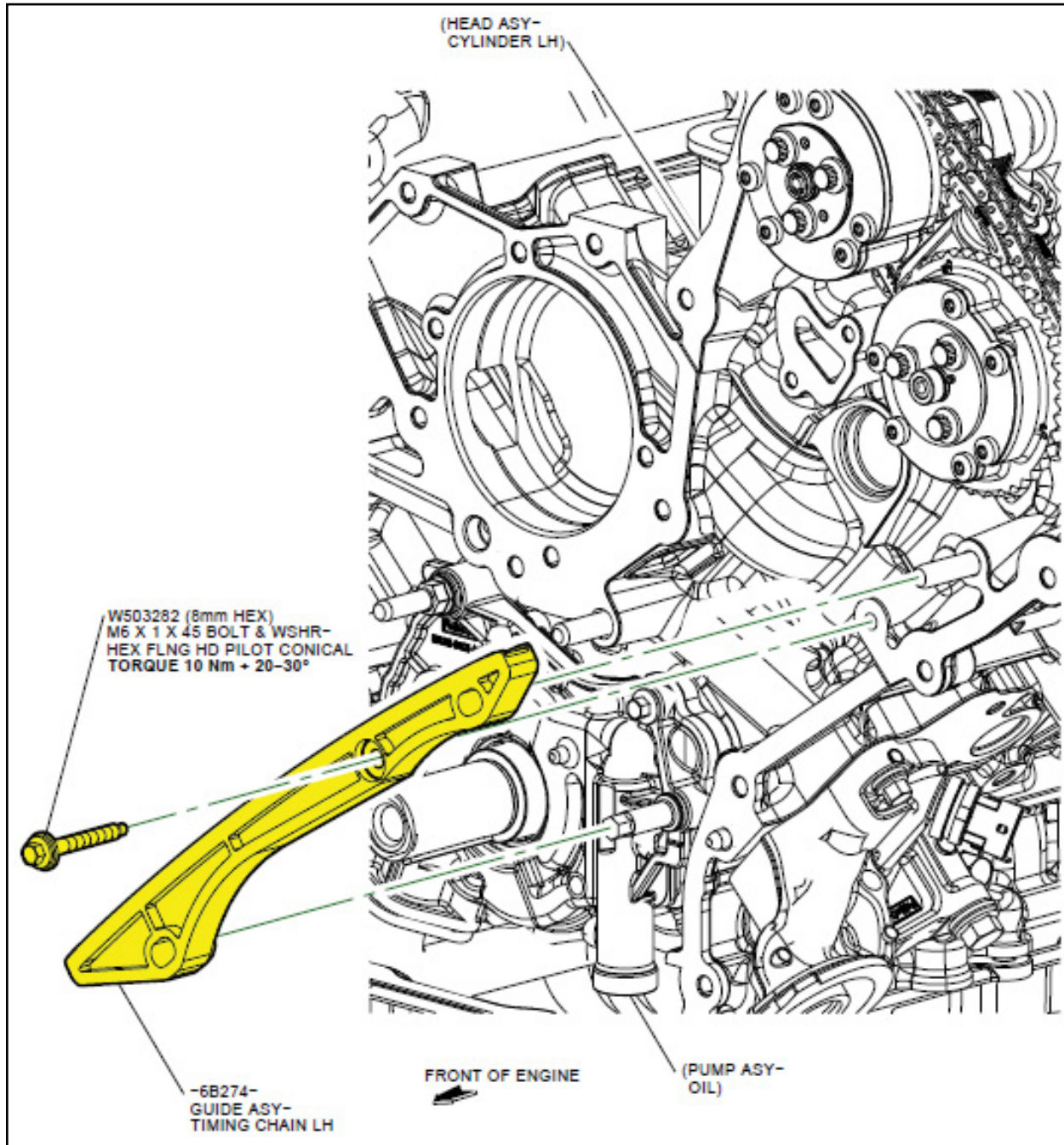

Ford Factory Shop Manual purchase options www.motorcraftservice.com



FORD PERFORMANCE

M-6004-A5018
2018-2023 Mustang 5.0L
Chain-drive kit

NO PART OF THIS DOCUMENT MAY BE REPRODUCED WITHOUT PRIOR AGREEMENT AND WRITTEN PERMISSION OF FORD PERFORMANCE PARTS

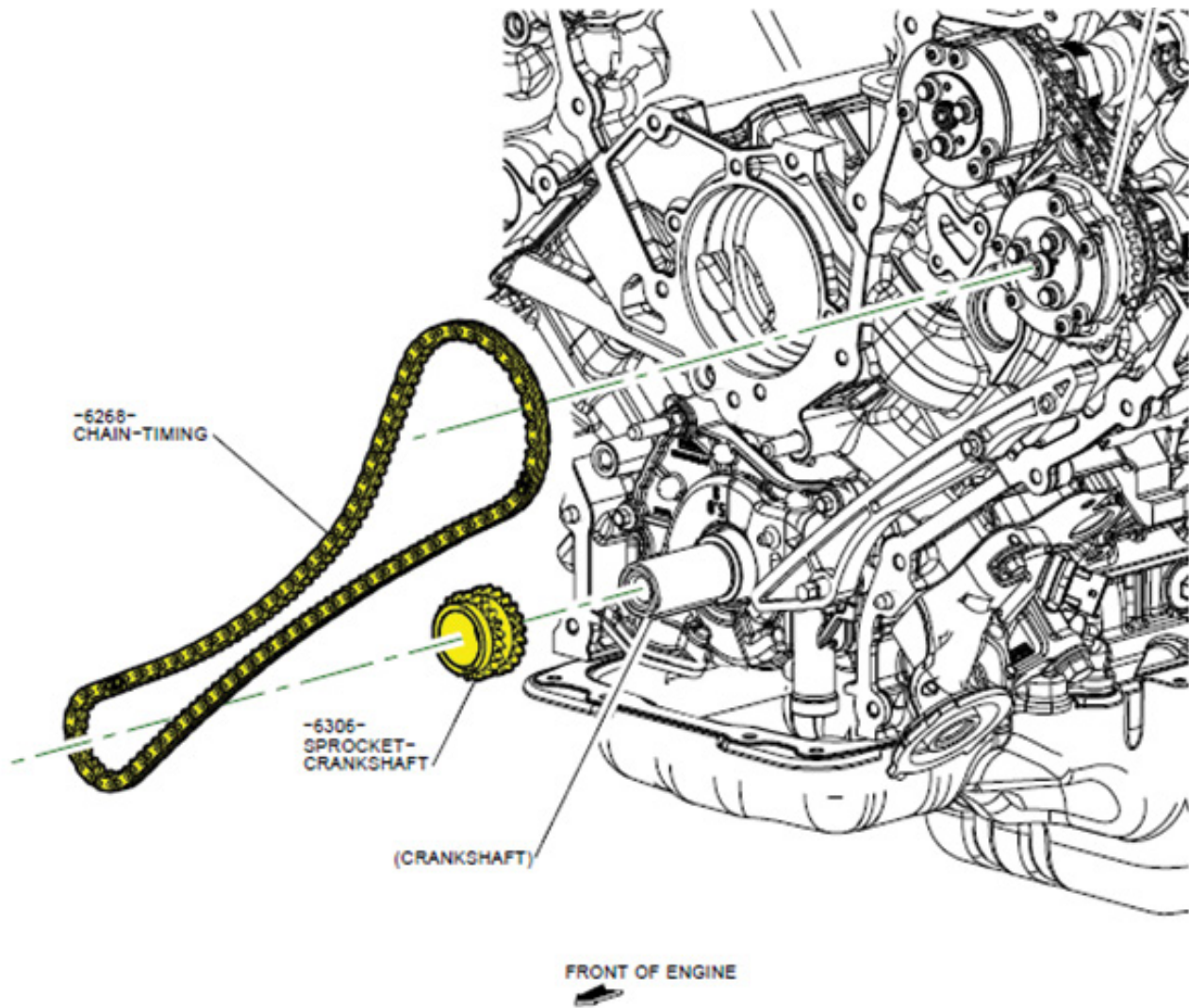

Ford Factory Shop Manual purchase options www.motorcraftservice.com



FORD PERFORMANCE

M-6004-A5018
2018-2023 Mustang 5.0L
Chain-drive kit

NO PART OF THIS DOCUMENT MAY BE REPRODUCED WITHOUT PRIOR AGREEMENT AND WRITTEN PERMISSION OF FORD PERFORMANCE PARTS

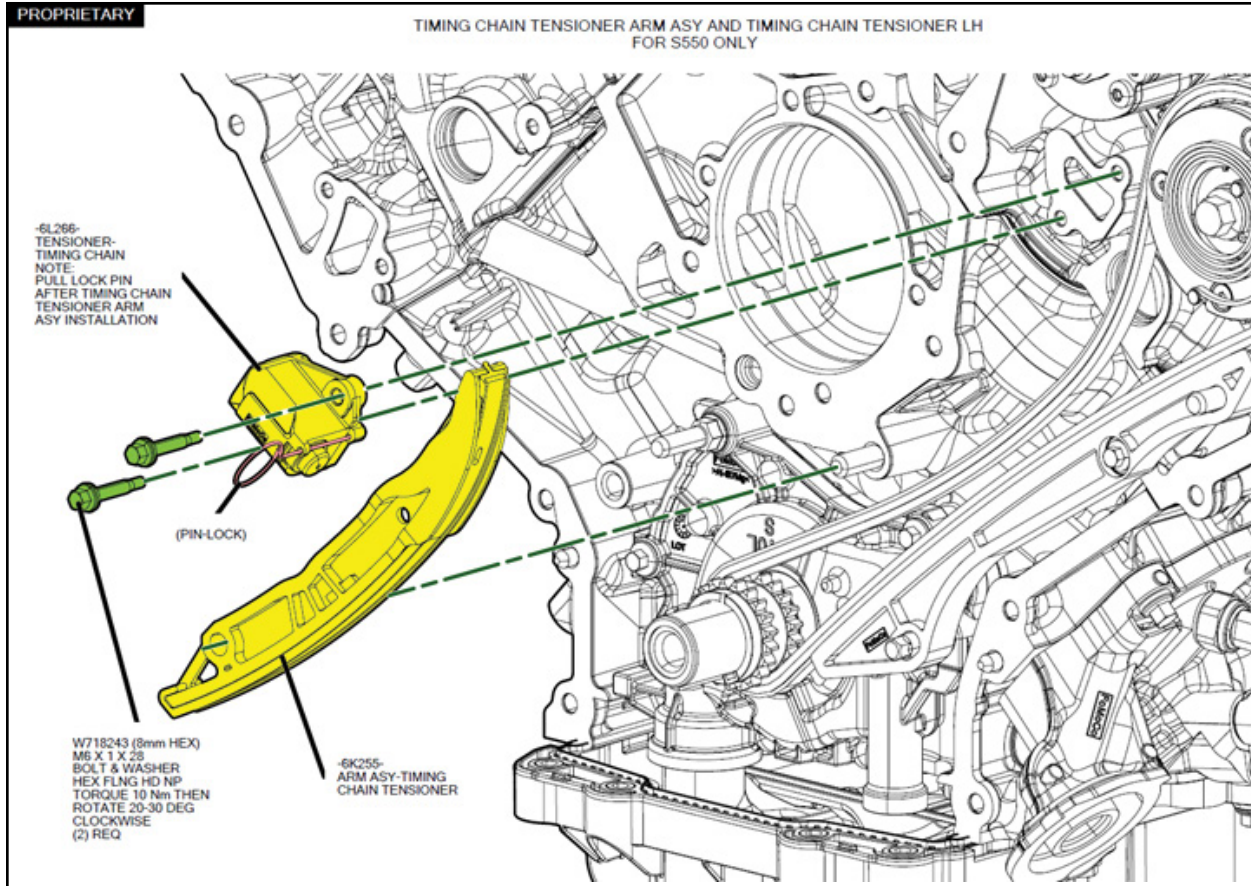

Ford Factory Shop Manual purchase options www.motorcraftservice.com



FORD PERFORMANCE

M-6004-A5018 2018-2023 Mustang 5.0L Chain-drive kit

NO PART OF THIS DOCUMENT MAY BE REPRODUCED WITHOUT PRIOR AGREEMENT AND WRITTEN PERMISSION OF FORD PERFORMANCE PARTS

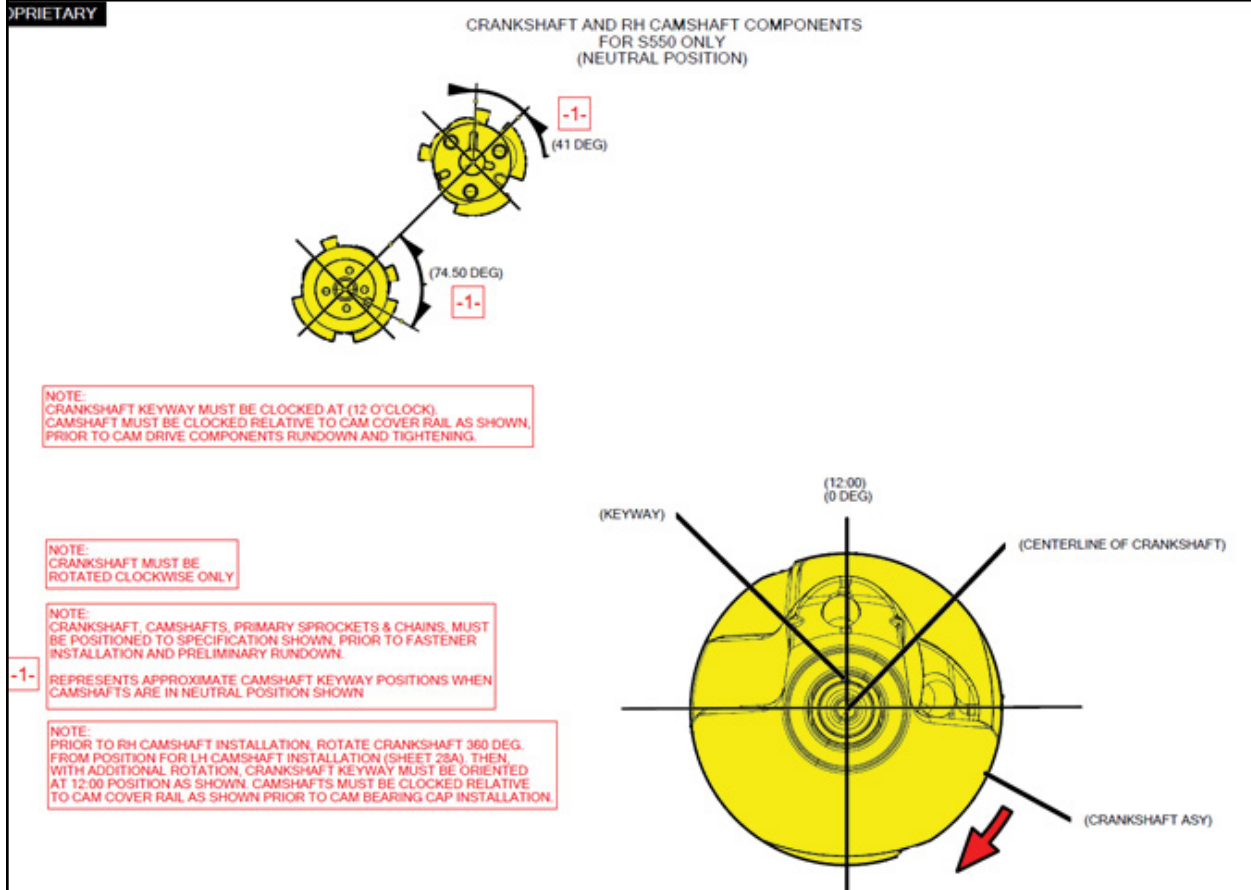

Ford Factory Shop Manual purchase options www.motorcraftservice.com



FORD PERFORMANCE

M-6004-A5018
2018-2023 Mustang 5.0L
Chain-drive kit

NO PART OF THIS DOCUMENT MAY BE REPRODUCED WITHOUT PRIOR AGREEMENT AND WRITTEN PERMISSION OF FORD PERFORMANCE PARTS

NOTE: Do not remove the secondary timing chain tensioner shipping clip, until instructed to do so.

NOTE: The secondary timing chain tensioner and shoe are of a new design. The secondary timing chain tensioner is shorter than the previous design and does not extend through the bottom of the camshaft mega cap. The new design shoe has tabs that contact the front of the mega cap when installed.

Apply clean engine oil to the secondary timing chain tensioner O-ring seals and mega cap bore.

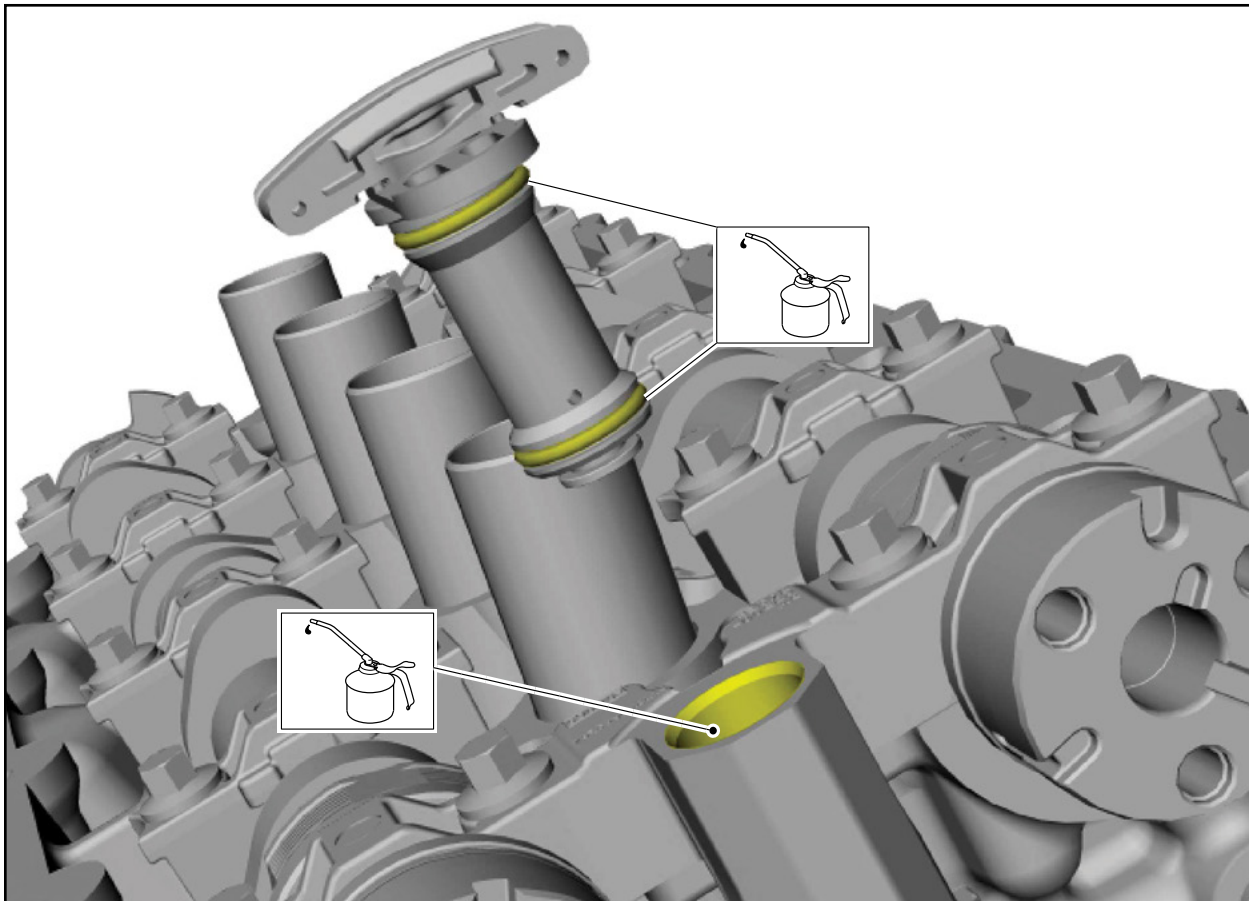

Ford Factory Shop Manual purchase options www.motorcraftservice.com



FORD PERFORMANCE

M-6004-A5018 2018-2023 Mustang 5.0L Chain-drive kit

NO PART OF THIS DOCUMENT MAY BE REPRODUCED WITHOUT PRIOR AGREEMENT AND WRITTEN PERMISSION OF FORD PERFORMANCE PARTS

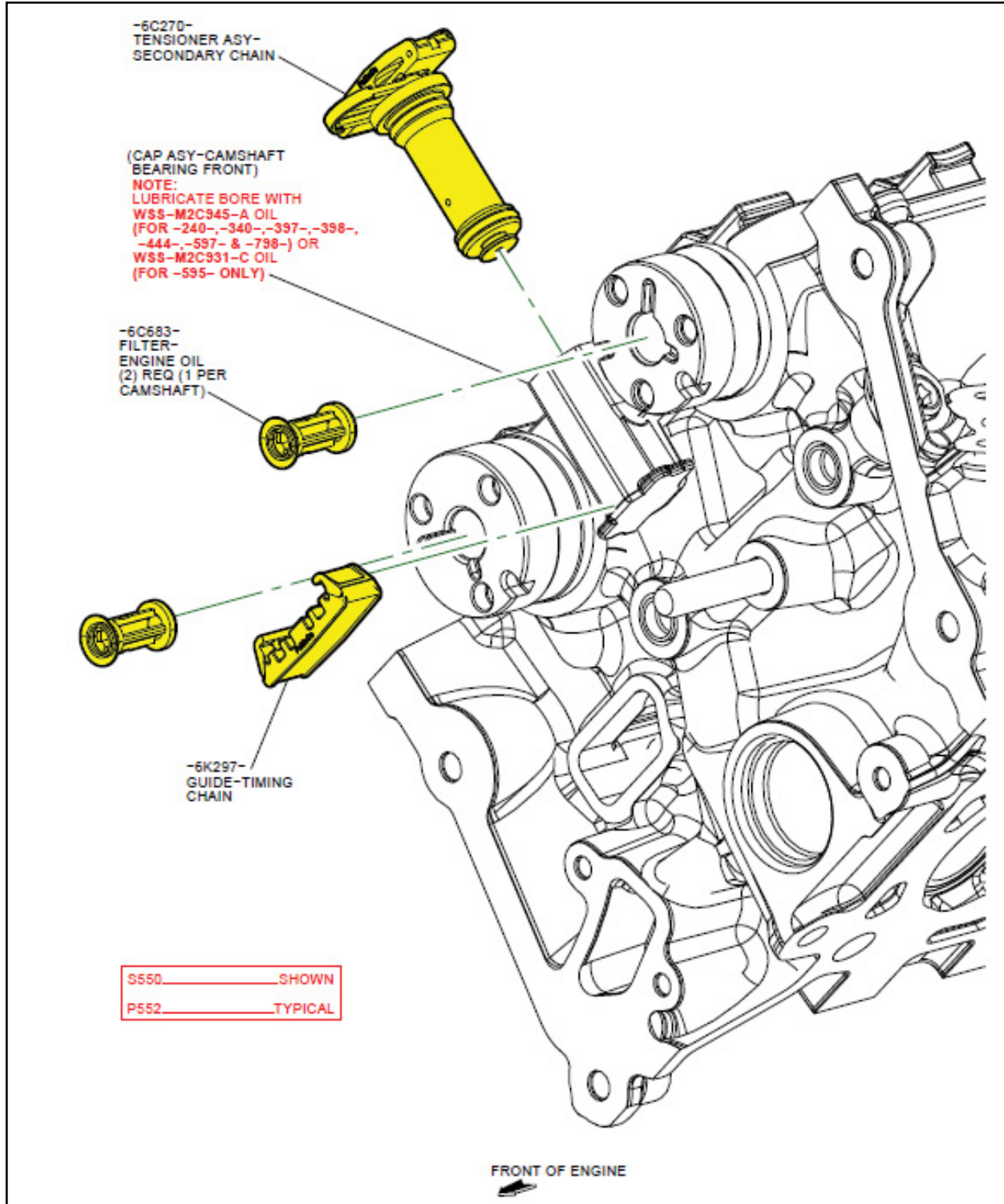

Ford Factory Shop Manual purchase options www.motorcraftservice.com



FORD PERFORMANCE

M-6004-A5018
2018-2023 Mustang 5.0L
Chain-drive kit

NO PART OF THIS DOCUMENT MAY BE REPRODUCED WITHOUT PRIOR AGREEMENT AND WRITTEN PERMISSION OF FORD PERFORMANCE PARTS

Install the secondary timing chain tensioner by pushing it down all the way until a snap is heard and the tensioner is seated all the way down the mega cap bore.

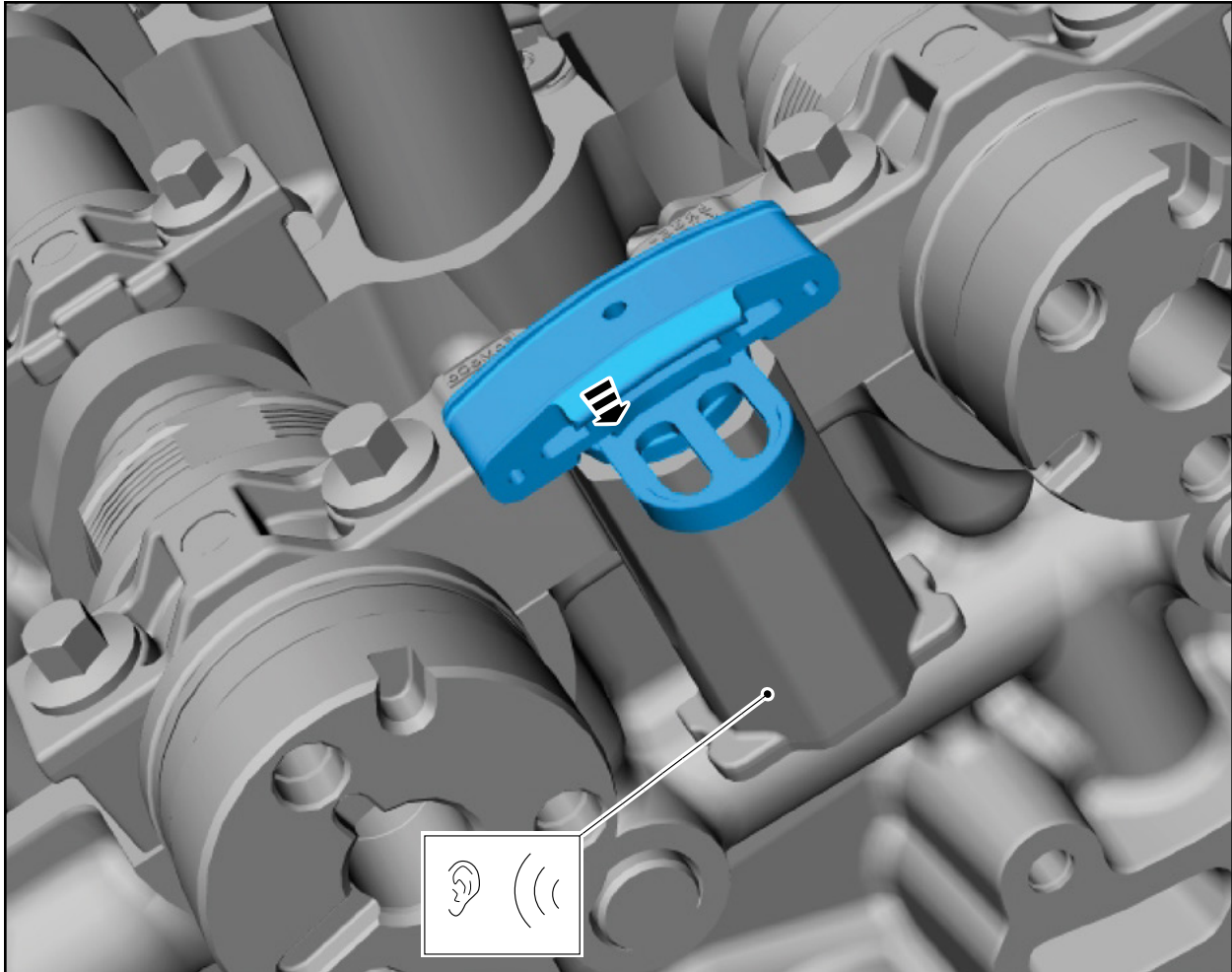

Ford Factory Shop Manual purchase options www.motorcraftservice.com



FORD PERFORMANCE

M-6004-A5018
2018-2023 Mustang 5.0L
Chain-drive kit

NO PART OF THIS DOCUMENT MAY BE REPRODUCED WITHOUT PRIOR AGREEMENT AND WRITTEN PERMISSION OF
FORD PERFORMANCE PARTS

Install the secondary timing chain tensioner shoe.

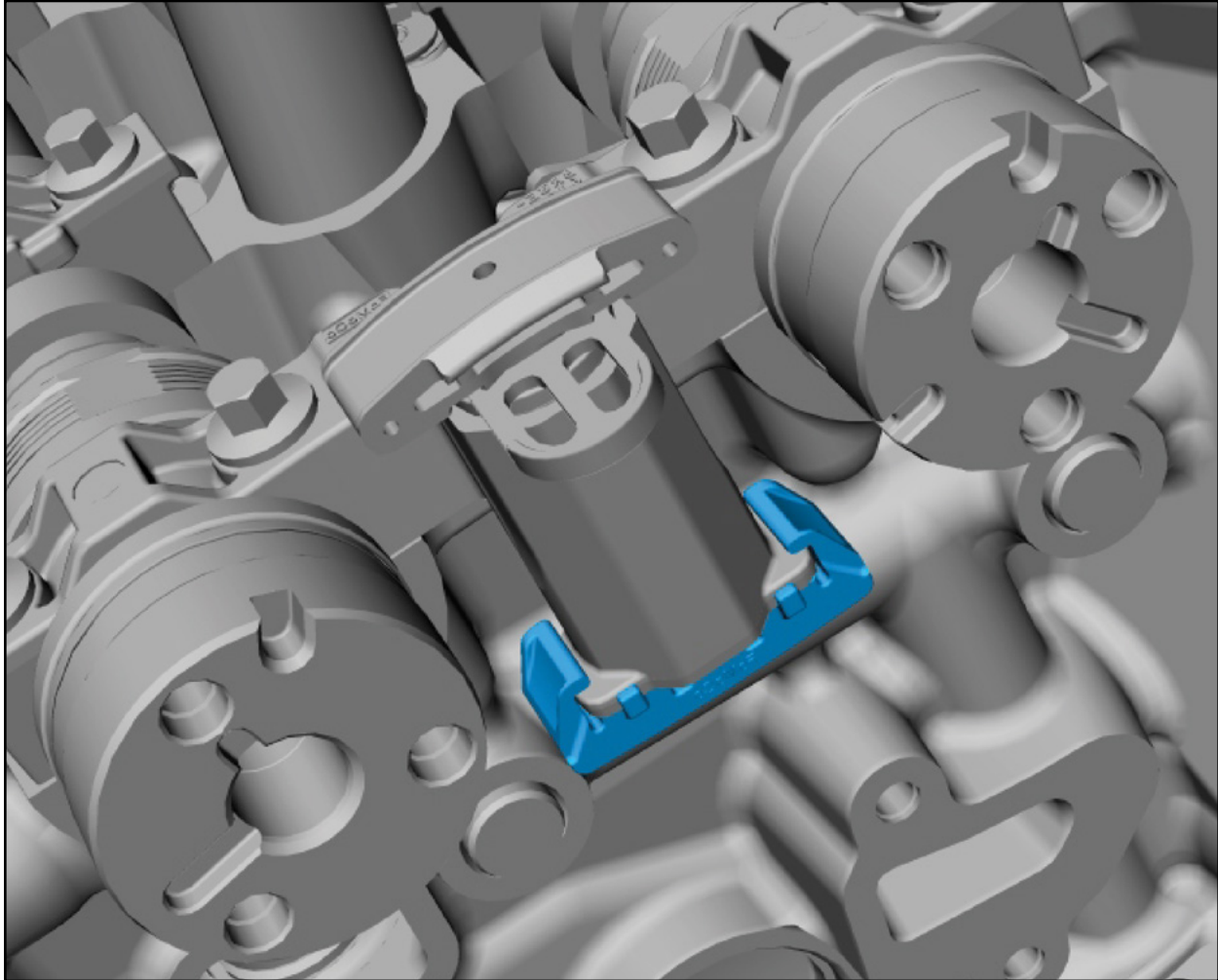

Ford Factory Shop Manual purchase options www.motorcraftservice.com



FORD PERFORMANCE

M-6004-A5018 2018-2023 Mustang 5.0L Chain-drive kit

NO PART OF THIS DOCUMENT MAY BE REPRODUCED WITHOUT PRIOR AGREEMENT AND WRITTEN PERMISSION OF FORD PERFORMANCE PARTS

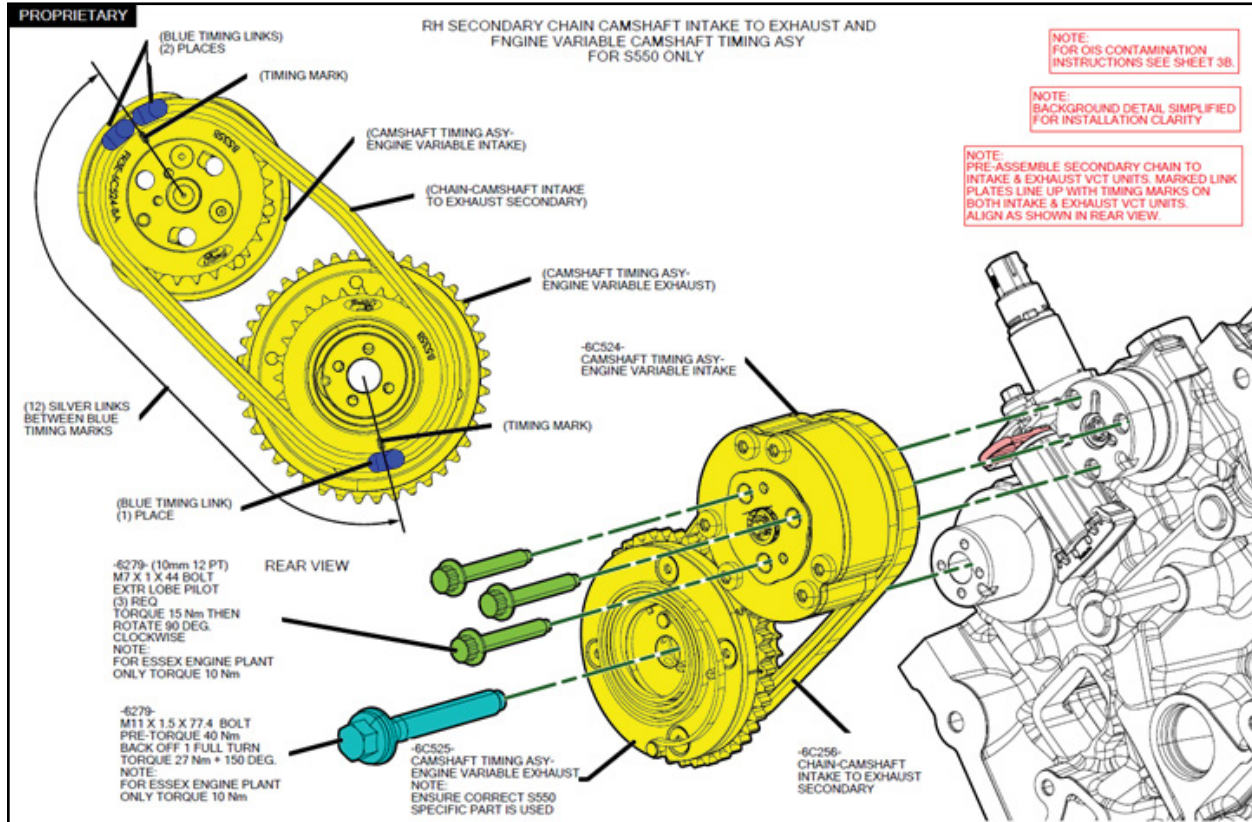

Ford Factory Shop Manual purchase options www.motorcraftservice.com



FORD PERFORMANCE

M-6004-A5018
2018-2023 Mustang 5.0L
Chain-drive kit

NO PART OF THIS DOCUMENT MAY BE REPRODUCED WITHOUT PRIOR AGREEMENT AND WRITTEN PERMISSION OF FORD PERFORMANCE PARTS

Remove and discard the secondary timing chain tensioner shipping clip.

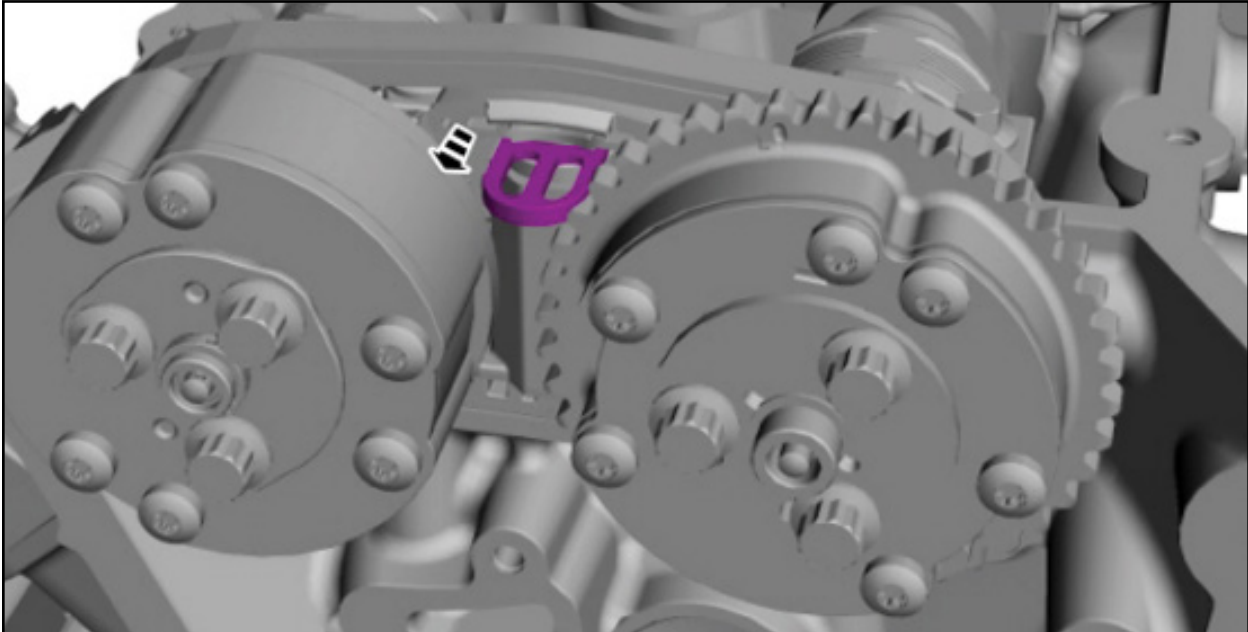

Activate the secondary timing chain tensioner by pressing down on the secondary timing chain and tensioner top shoe until it bottoms out, let go of the tensioner and it will spring up putting tension on the chain.

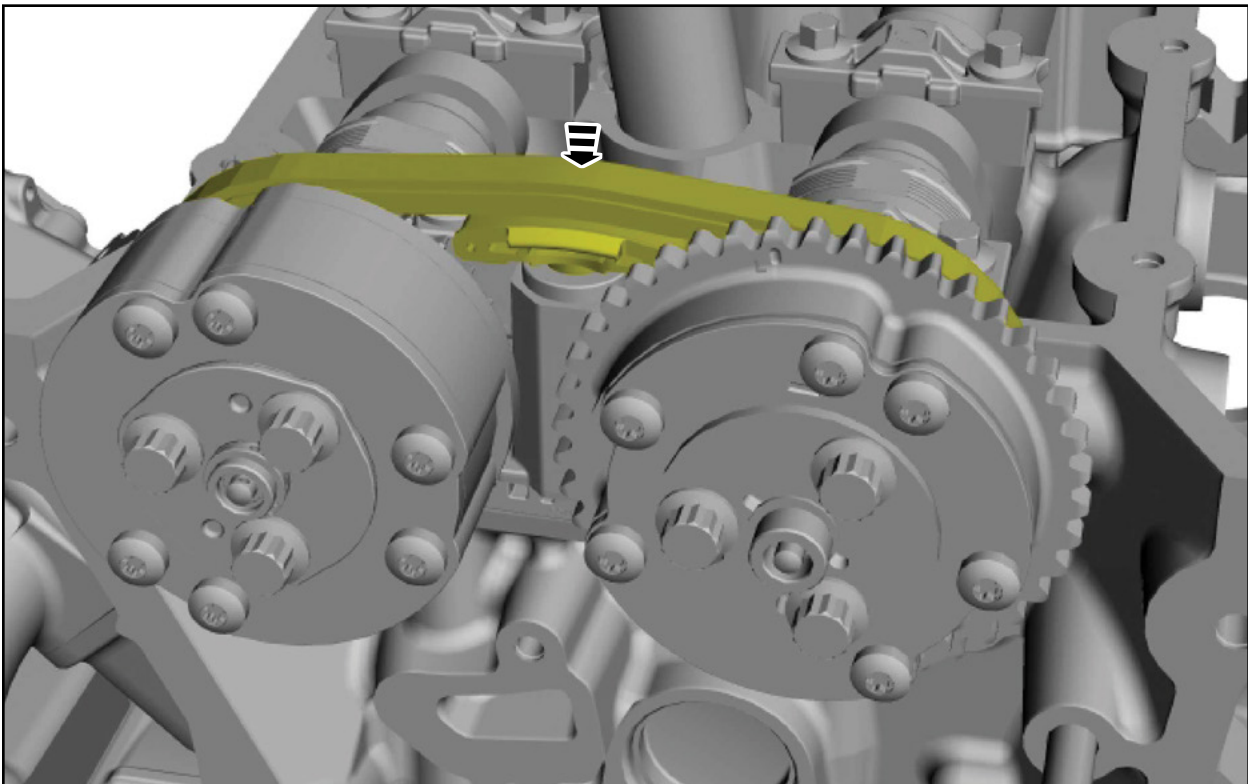

Ford Factory Shop Manual purchase options www.motorcraftservice.com



FORD PERFORMANCE

M-6004-A5018
2018-2023 Mustang 5.0L
Chain-drive kit

NO PART OF THIS DOCUMENT MAY BE REPRODUCED WITHOUT PRIOR AGREEMENT AND WRITTEN PERMISSION OF FORD PERFORMANCE PARTS

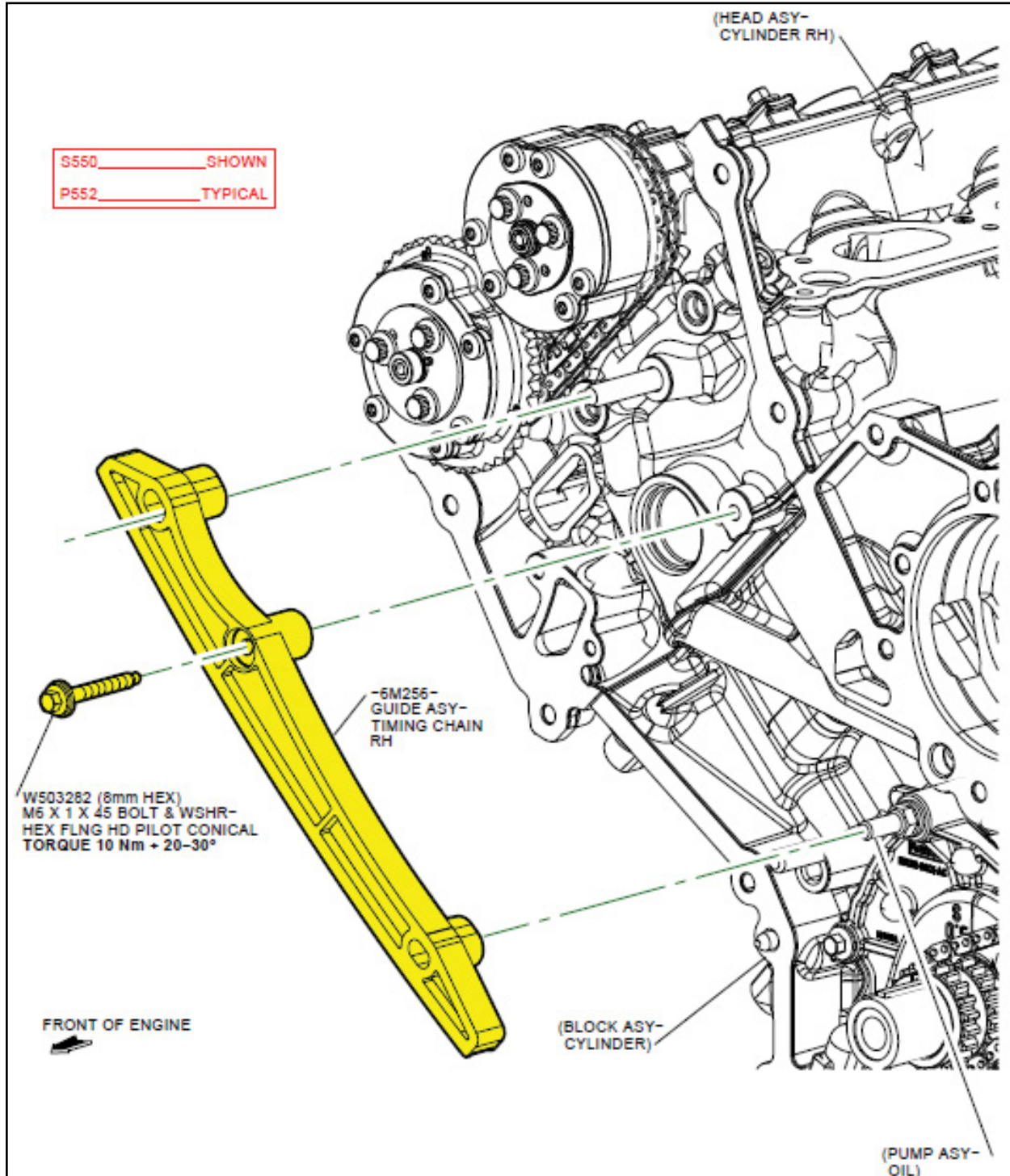

Ford Factory Shop Manual purchase options www.motorcraftservice.com



FORD PERFORMANCE

M-6004-A5018
2018-2023 Mustang 5.0L
Chain-drive kit

NO PART OF THIS DOCUMENT MAY BE REPRODUCED WITHOUT PRIOR AGREEMENT AND WRITTEN PERMISSION OF FORD PERFORMANCE PARTS

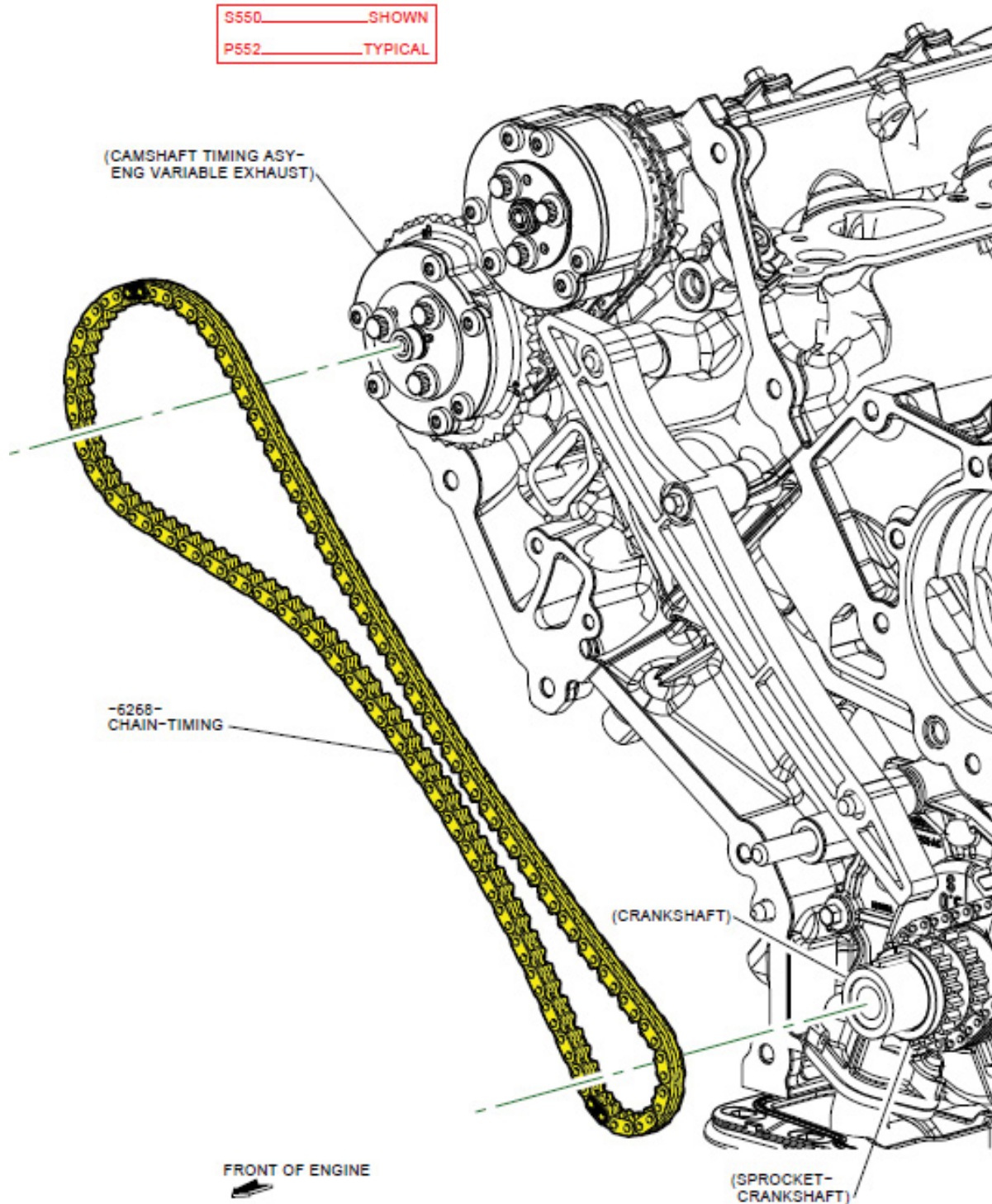

Ford Factory Shop Manual purchase options www.motorcraftservice.com



FORD PERFORMANCE

M-6004-A5018
2018-2023 Mustang 5.0L
Chain-drive kit

NO PART OF THIS DOCUMENT MAY BE REPRODUCED WITHOUT PRIOR AGREEMENT AND WRITTEN PERMISSION OF
FORD PERFORMANCE PARTS

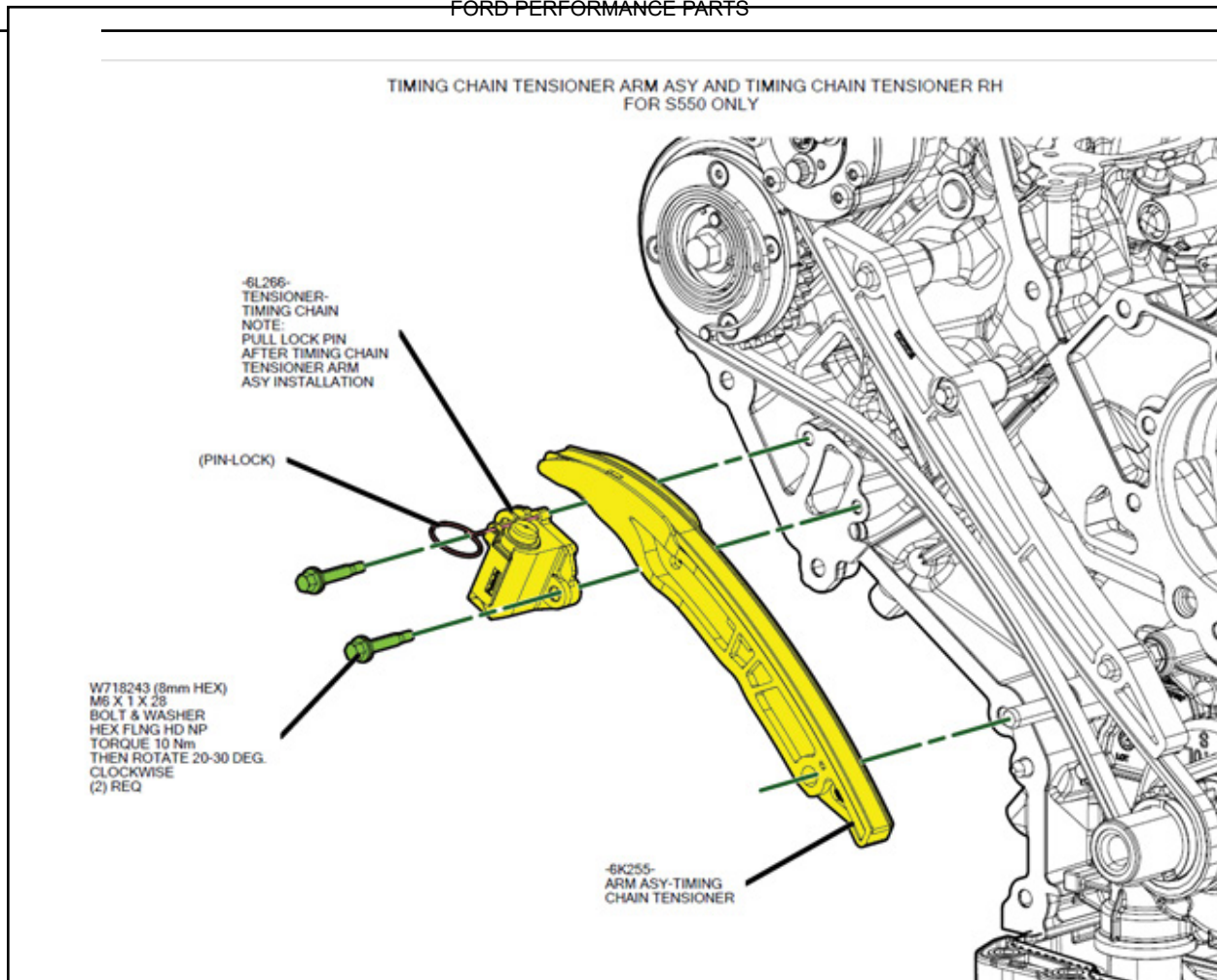

Ford Factory Shop Manual purchase options www.motorcraftservice.com