



FORD PERFORMANCE

M-6004-A50D
2024- Mustang 5.0L
Chain-drive kit

NO PART OF THIS DOCUMENT MAY BE REPRODUCED WITHOUT PRIOR WRITTEN PERMISSION OF FORD PERFORMANCE PARTS
© Ford Motor Company 2021

PRIOR TO INSTALLATION READ THESE INSTRUCTION COMPETELY
For questions, Call the FORD PERFORMANCE Techline 1-800-367-3788

Please visit <https://www.performanceparts.ford.com> for warranty information

Part #	Description	Qty
9L8Z-6C683-A	VCT/camshaft filter	4
BR3Z-6A340-A	Damper bolt	1
BR3Z-6268-A	Secondary timing chain	2
FR3Z-6268-A	Primary timing chain	2
BR3Z-6279-A	VCT phaser bolt	6
JL3Z-6L266-C	Primary chain tensioner	2
JL3Z-6B274-B	Chain guide	1
JL3Z-6K255-A	Tensioner arm	2
JL3Z-6M256-A	Chain guide	1
JR3Z-6C525-A	Exhaust VCT sprocket	2
JR3Z-6279-A	Exhaust phaser bolt	2
KR3Z-6306-B	Crank sprocket	1
ML3Z-6K254-A	Secondary chain tensioner	2
ML3Z-6C524-B	Intake VCT sprocket	2
ML3Z-6K297-A	Secondary tensioner guide	2
N806183-S437	Oil pump bolt	2
N807033-S439	Damper bolt washer	1
W503282-S437	Chain guide bolt	2
W701501-S	Dowel	1
W714251-S300	Oil pump stud bolt	1
W714252-S300	Oil pump stud bolt	1
W714258-S300	Dowel	3
W718243-S437	Primary tensioner bolt	4

Ford Factory Shop Manual purchase options www.motorcraftservice.com



FORD PERFORMANCE

M-6004-A50D 2024- Mustang 5.0L Chain-drive kit

NO PART OF THIS DOCUMENT MAY BE REPRODUCED WITHOUT PRIOR WRITTEN PERMISSION OF FORD PERFORMANCE PARTS
© Ford Motor Company 2021

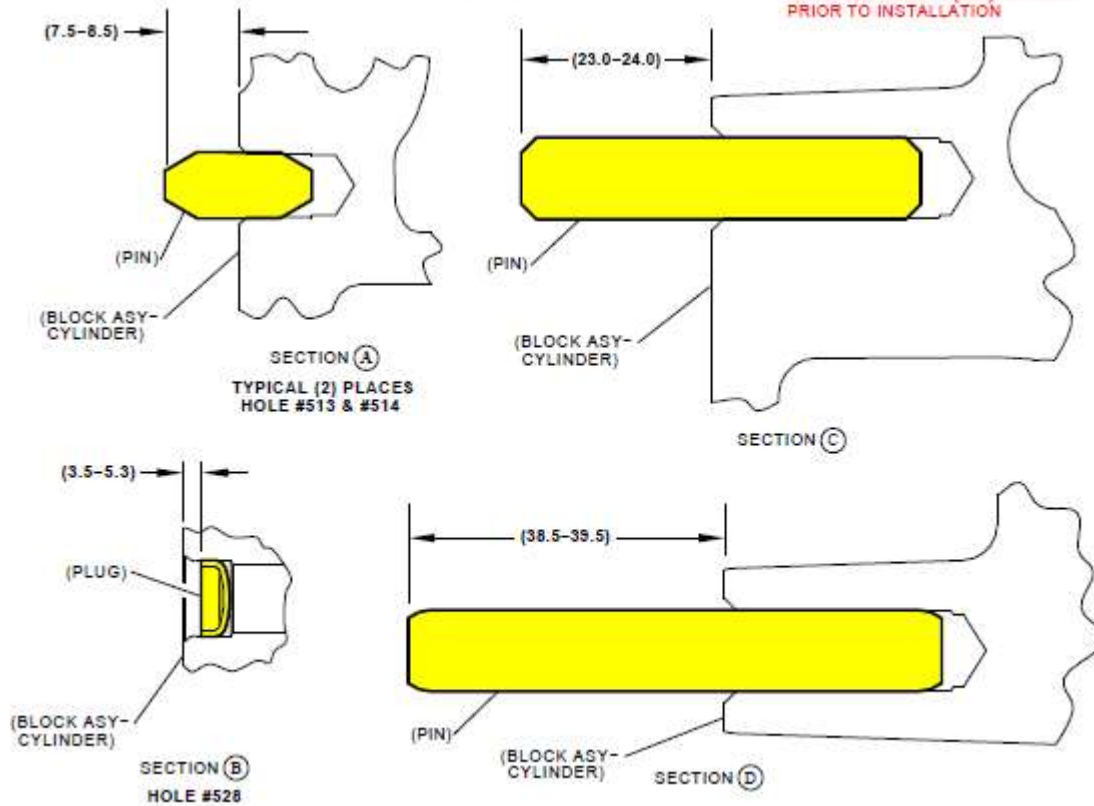
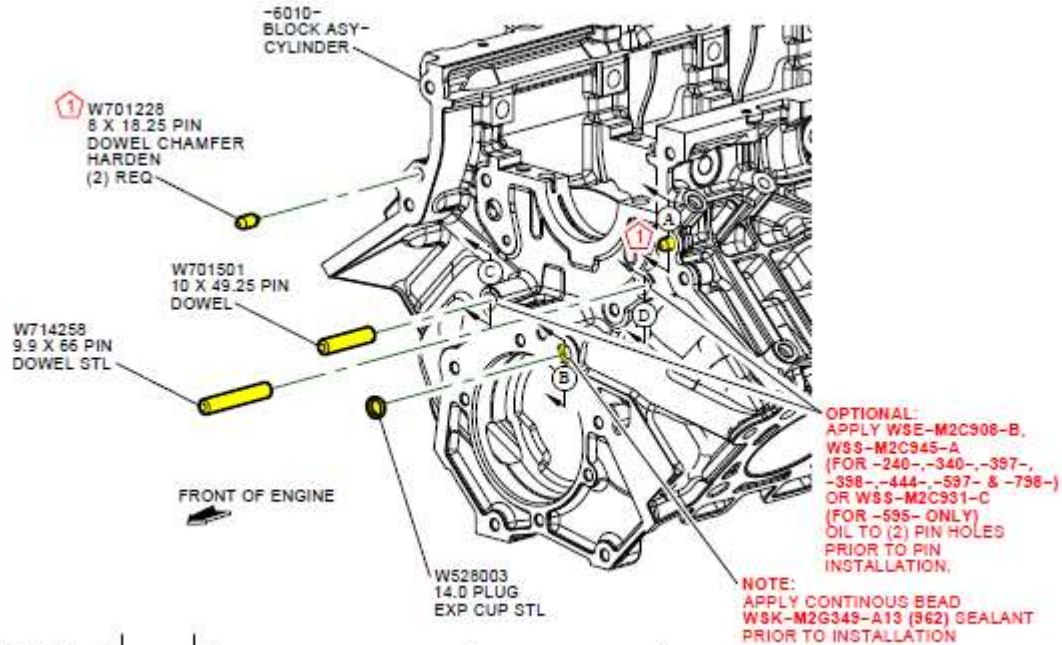

Ford Factory Shop Manual purchase options www.motorcraftservice.com



FORD PERFORMANCE

M-6004-A50D 2024- Mustang 5.0L Chain-drive kit

NO PART OF THIS DOCUMENT MAY BE REPRODUCED WITHOUT PRIOR WRITTEN PERMISSION OF FORD PERFORMANCE PARTS
© Ford Motor Company 2021

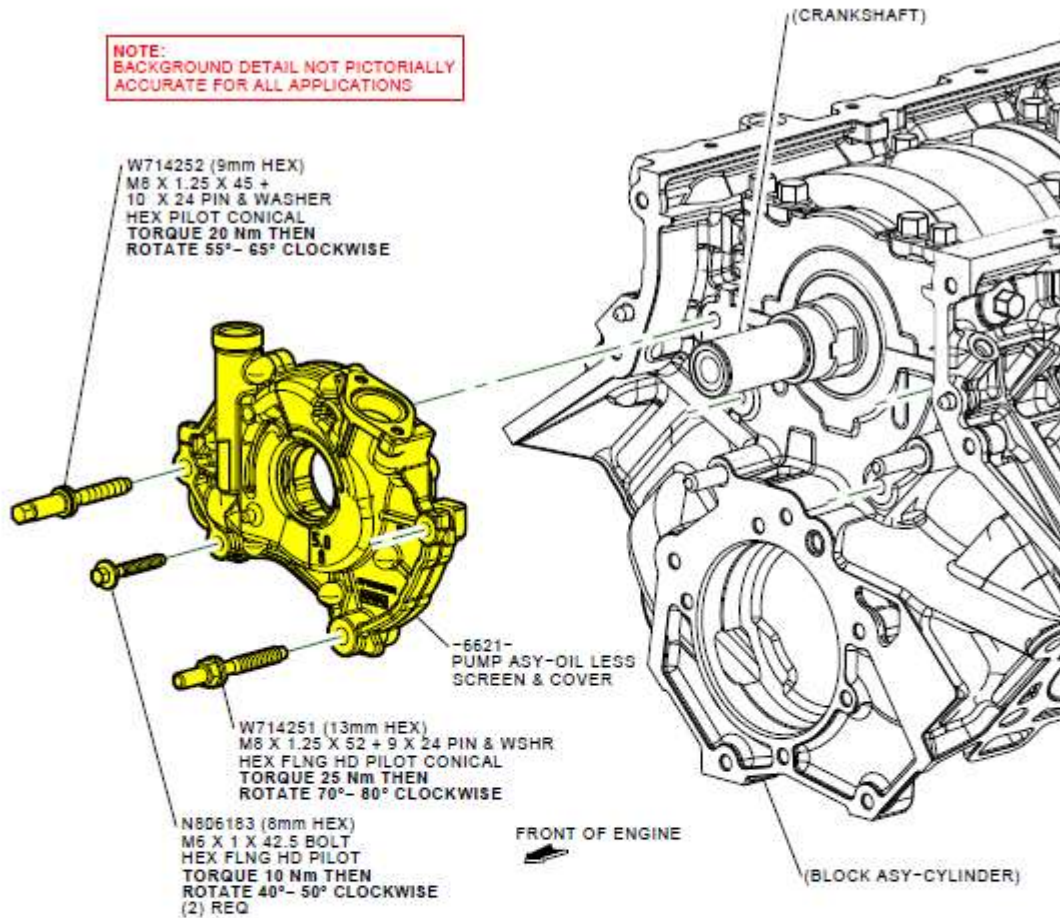

ASSEMBLY PROCEDURE

1. ROTATE INNER ROTOR OF OIL PUMP ASY (-6621-) TO ALIGN WITH FLATS ON CRANKSHAFT POST AND SLIP OIL PUMP OVER UNTIL SEATED AGAINST BLOCK.

NOTE:
PUMP MUST BE HELD AGAINST BLOCK UNTIL BOLTS ARE TORQUED.

2. ROTATE OIL PUMP ASY, ALIGN BOLT HOLES, INSTALL (4) FASTENERS AND SIMULTANEOUSLY TORQUE TO SPECIFICATION.

NOTE:
FOR PRODUCTION, ROTATION OF CRANKSHAFT DURING TORQUE PROCEDURE IS REQUIRED.

SINGLE WRENCH METHOD (SERVICE)

1. ROTATE INNER ROTOR OF OIL PUMP ASY TO ALIGN WITH FLATS ON CRANKSHAFT POST AND SLIP OIL PUMP OVER UNTIL SEATED AGAINST BLOCK.

NOTE:
PUMP MUST BE HELD AGAINST BLOCK UNTIL BOLTS ARE TORQUED.

2. ROTATE OIL PUMP ASY, ALIGN BOLT HOLES, INSTALL (4) FASTENERS.
3. TORQUE FASTENERS 0 Nm.
4. TORQUE M8 FASTENER W714251 25 Nm, M8 FASTENER W714252 20 Nm AND M6 FASTENERS N806183 10 Nm.
5. ROTATE M8 FASTENER W714251 70°- 80° CLOCKWISE, ROTATE M8 FASTENER W714252 55°- 65° CLOCKWISE AND M6 FASTENERS N806183 40°- 50° CLOCKWISE.

Ford Factory Shop Manual purchase options www.motorcraftservice.com



FORD PERFORMANCE

M-6004-A50D 2024- Mustang 5.0L Chain-drive kit

NO PART OF THIS DOCUMENT MAY BE REPRODUCED WITHOUT PRIOR WRITTEN PERMISSION OF FORD PERFORMANCE PARTS
© Ford Motor Company 2021

CRANKSHAFT AND LH CAMSHAFT COMPONENTS
FOR S650 ONLY
NEUTRAL POSITION

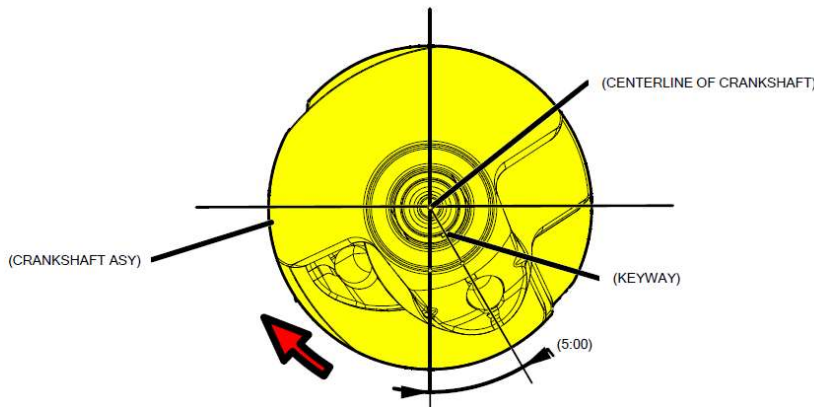
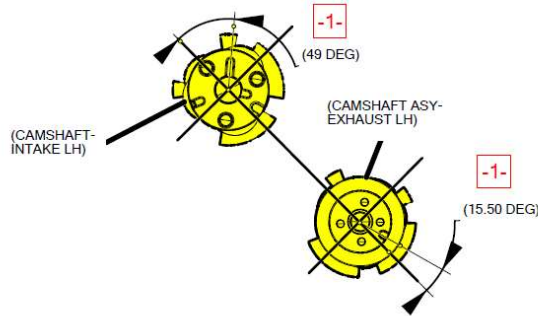

NOTE:
CRANKSHAFT MUST BE
ROTATED CLOCKWISE ONLY

-1- NOTE:
CRANKSHAFT, CAMSHAFTS, PRIMARY SPROCKETS & CHAINS, MUST
BE POSITIONED TO SPECIFICATION SHOWN, PRIOR TO FASTENER
INSTALLATION AND PRELIMINARY RUNDOWN.
REPRESENTS APPROXIMATE CAMSHAFT KEYWAY POSITIONS WHEN
CAMSHAFTS ARE IN NEUTRAL POSITION SHOWN

Ford Factory Shop Manual purchase options www.motorcraftservice.com



FORD PERFORMANCE

M-6004-A50D 2024- Mustang 5.0L Chain-drive kit

NO PART OF THIS DOCUMENT MAY BE REPRODUCED WITHOUT PRIOR WRITTEN PERMISSION OF FORD PERFORMANCE PARTS
© Ford Motor Company 2021

S550 _____ SHOWN
P552 _____ TYPICAL

-6C270-
TENSIONER ASY-
SECONDARY CHAIN

(CAP ASY-CAMSHAFT
BEARING FRONT)

NOTE:
LUBRICATE BORE WITH
WSS-M2C945-A OIL
(FOR -240-, -340-, -397-, -398-,
-444-, -597- & -798-) OR
WSS-M2C931-C OIL
(FOR -595- ONLY)

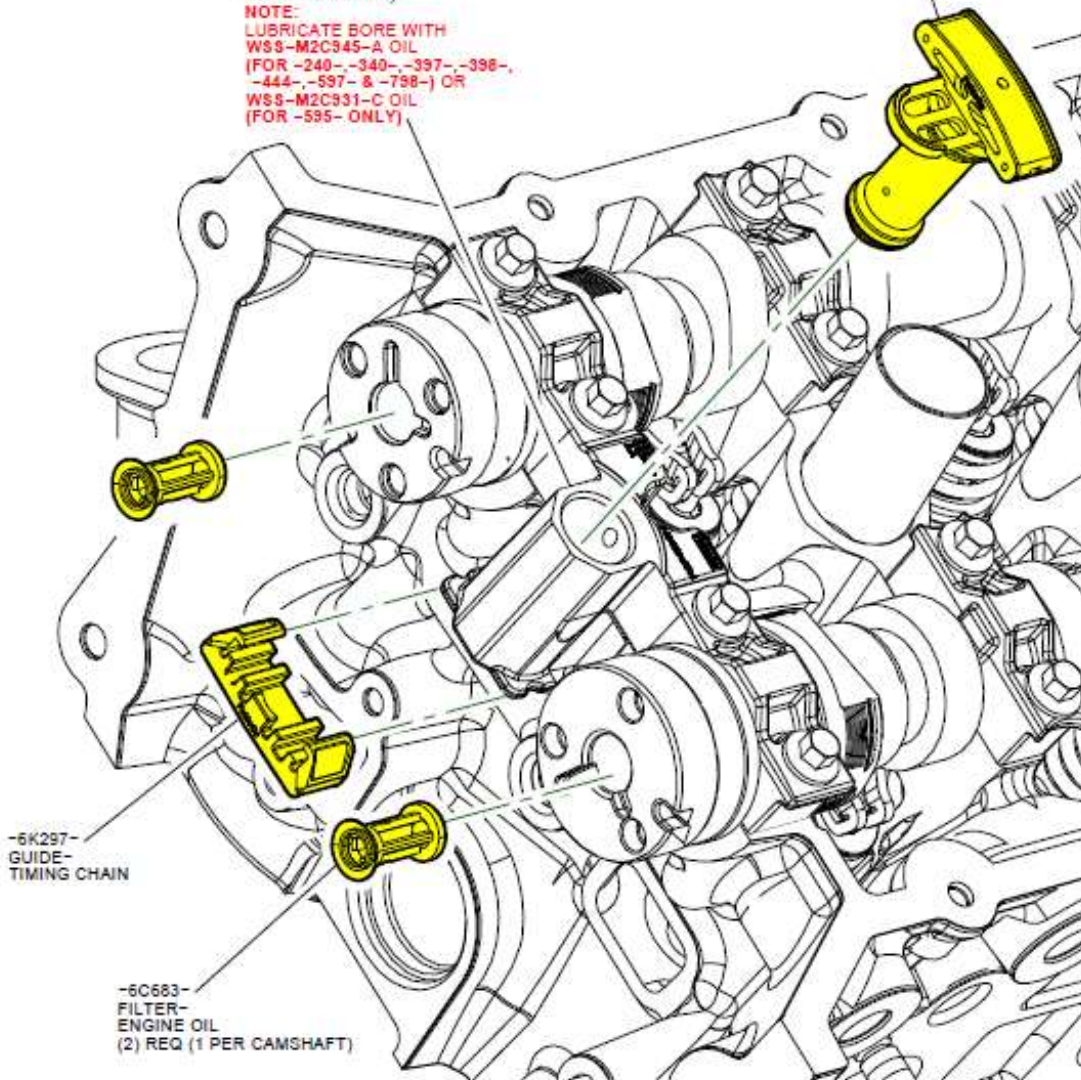

-6K297-
GUIDE-
TIMING CHAIN

-6C683-
FILTER-
ENGINE OIL
(2) REQ (1 PER CAMSHAFT)

FRONT OF ENGINE

Ford Factory Shop Manual purchase options www.motorcraftservice.com



FORD PERFORMANCE

M-6004-A50D 2024- Mustang 5.0L Chain-drive kit

NO PART OF THIS DOCUMENT MAY BE REPRODUCED WITHOUT PRIOR WRITTEN PERMISSION OF FORD PERFORMANCE PARTS
© Ford Motor Company 2021

LH SECONDARY CHAIN CAMSHAFT INTAKE TO EXHAUST AND
ENGINE VARIABLE CAMSHAFT TIMING ASY
FOR S650 ONLY

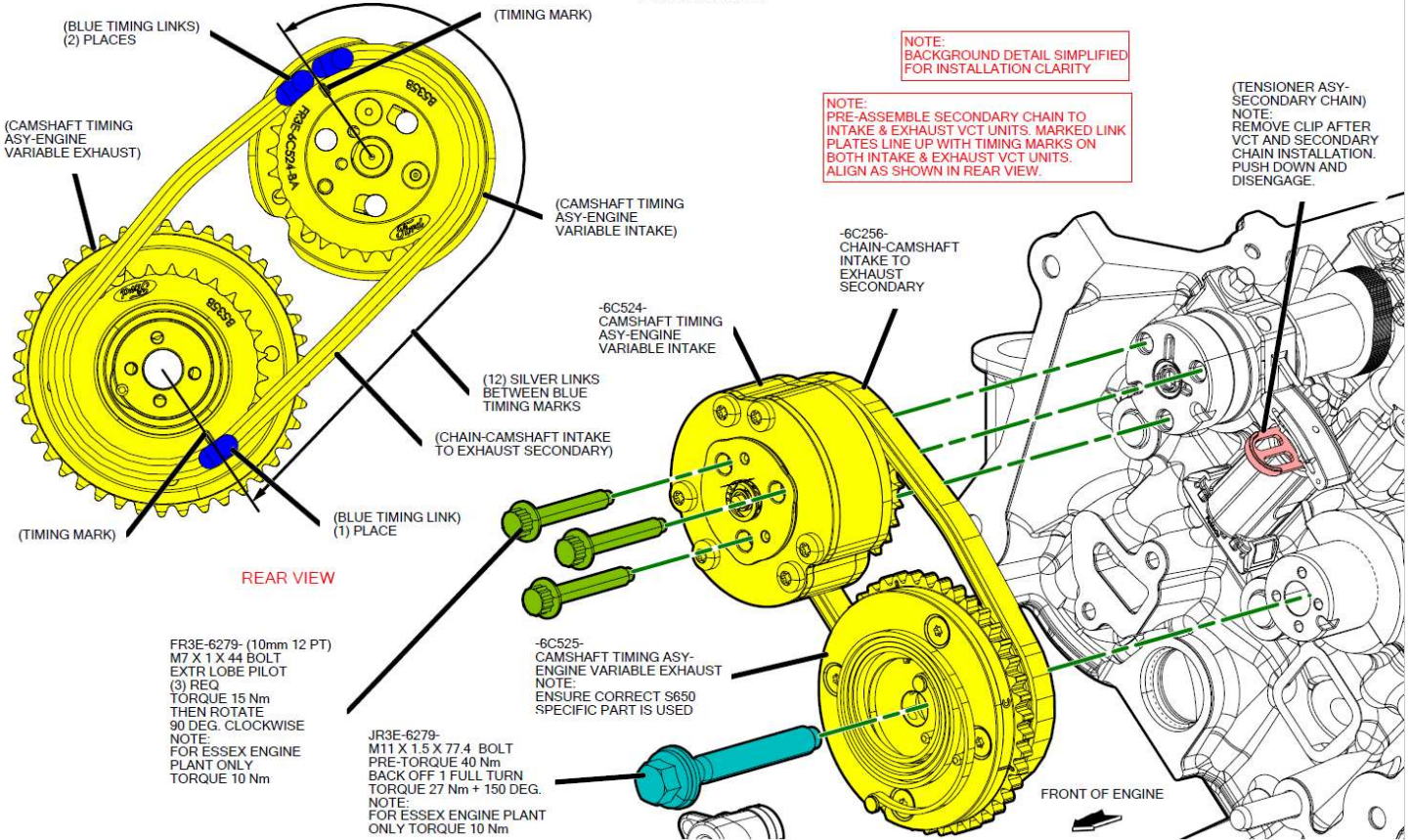

Ford Factory Shop Manual purchase options www.motorcraftservice.com



FORD PERFORMANCE

M-6004-A50D
2024- Mustang 5.0L
Chain-drive kit

NO PART OF THIS DOCUMENT MAY BE REPRODUCED WITHOUT PRIOR WRITTEN PERMISSION OF FORD PERFORMANCE PARTS
© Ford Motor Company 2021

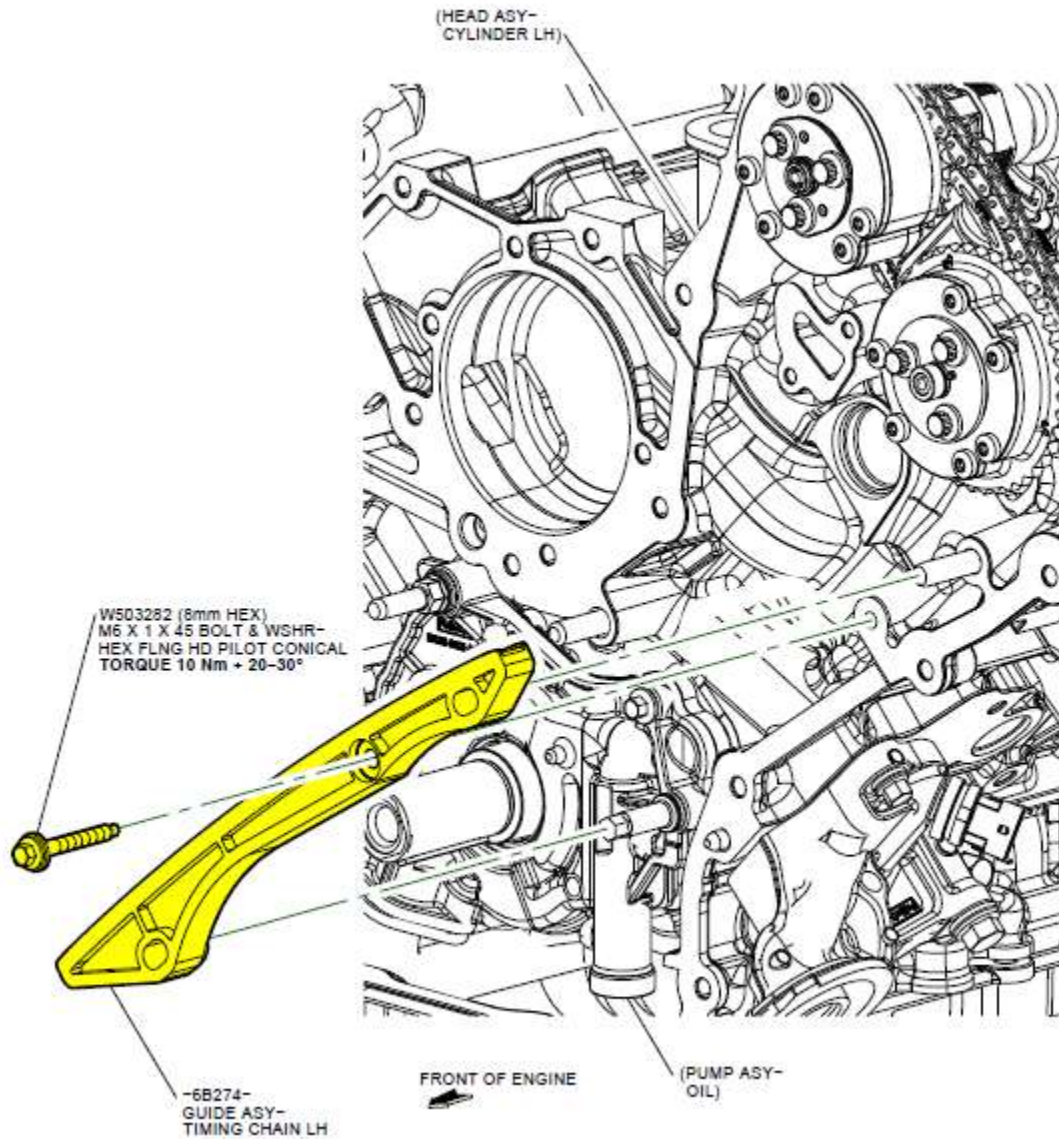

Ford Factory Shop Manual purchase options www.motorcraftservice.com



FORD PERFORMANCE

M-6004-A50D
2024- Mustang 5.0L
Chain-drive kit

NO PART OF THIS DOCUMENT MAY BE REPRODUCED WITHOUT PRIOR WRITTEN PERMISSION OF FORD PERFORMANCE PARTS
© Ford Motor Company 2021

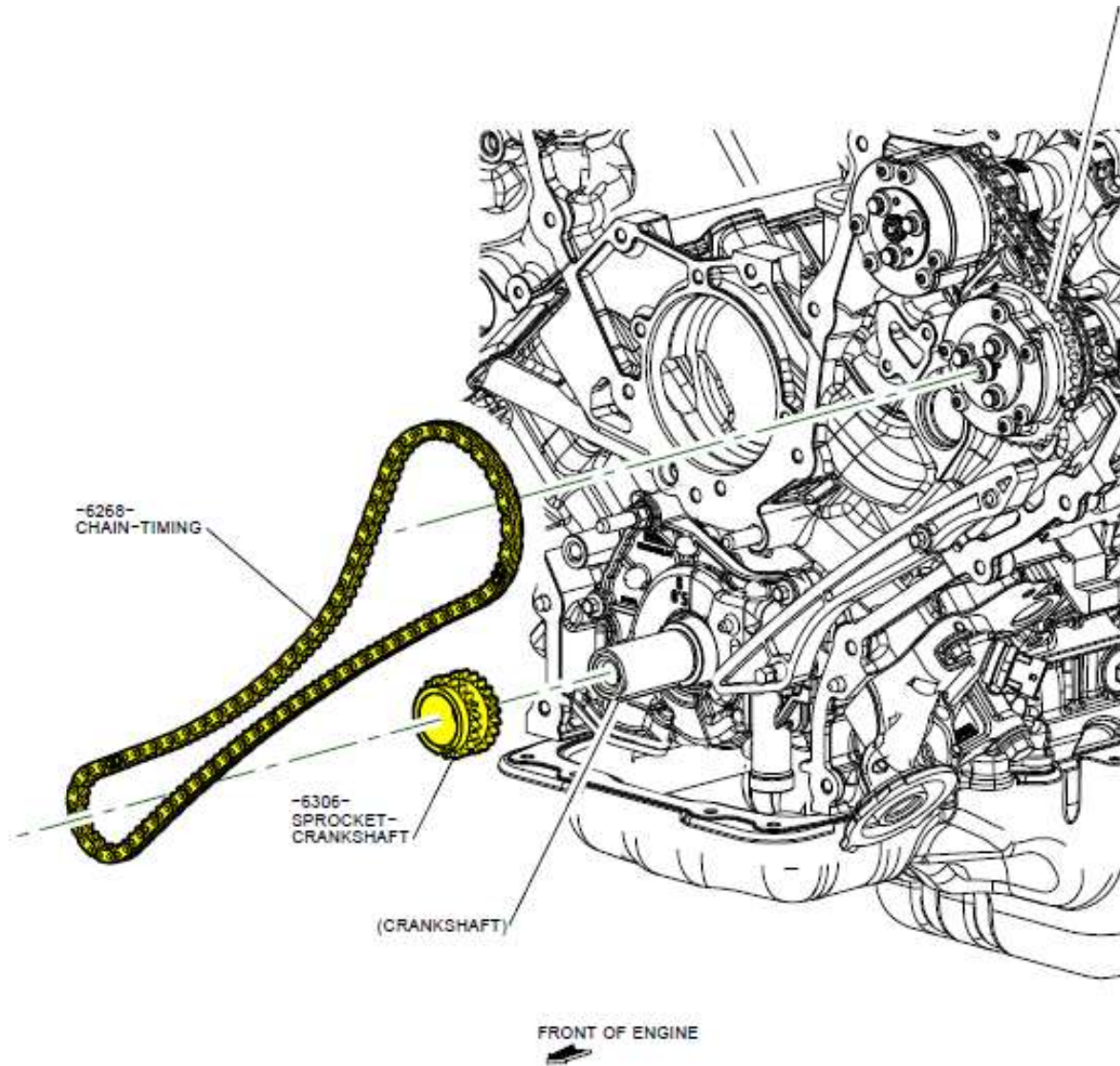

Ford Factory Shop Manual purchase options www.motorcraftservice.com



FORD PERFORMANCE

M-6004-A50D
2024- Mustang 5.0L
Chain-drive kit

NO PART OF THIS DOCUMENT MAY BE REPRODUCED WITHOUT PRIOR WRITTEN PERMISSION OF FORD PERFORMANCE PARTS
© Ford Motor Company 2021

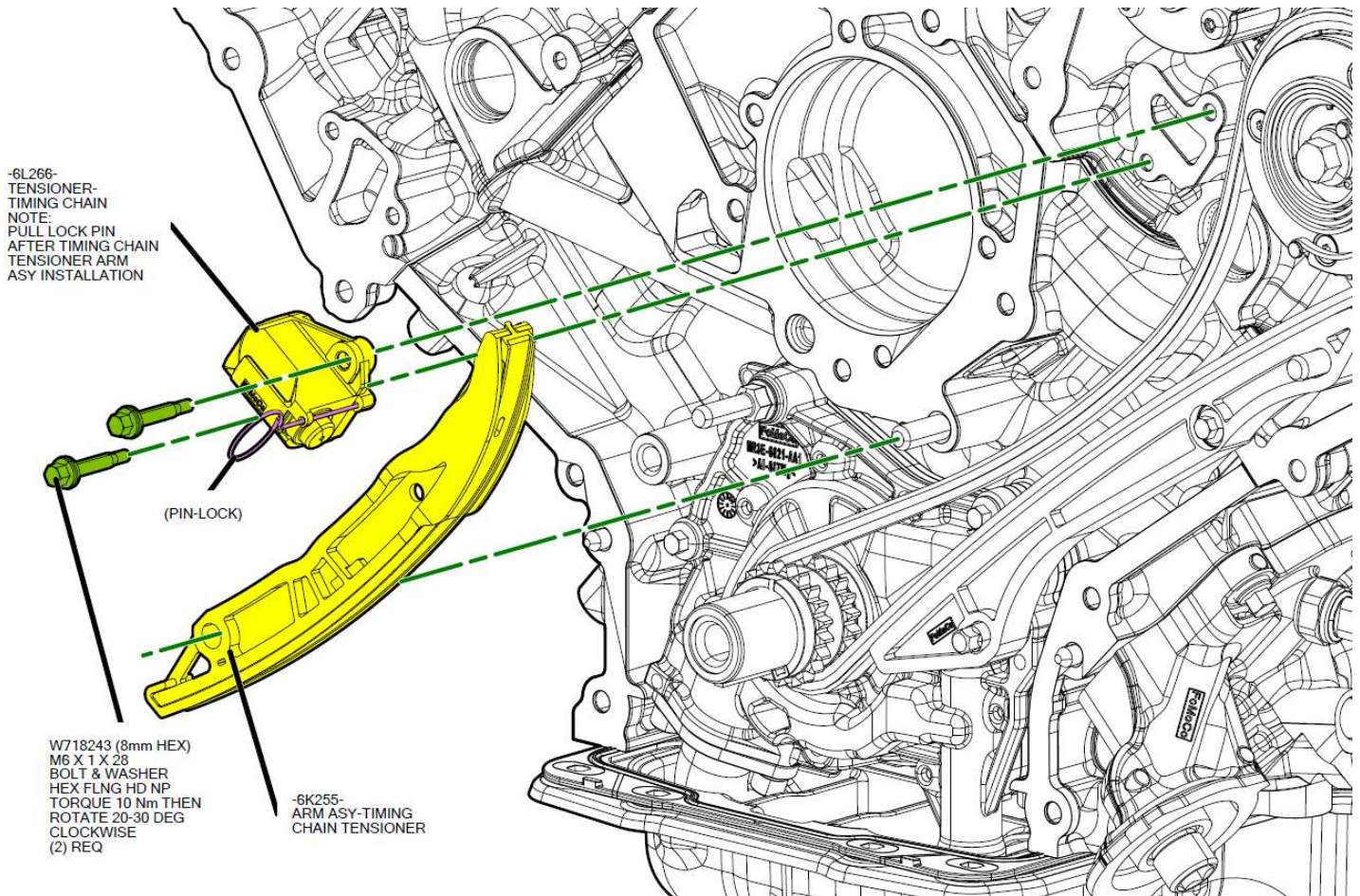

Ford Factory Shop Manual purchase options www.motorcraftservice.com



FORD PERFORMANCE

M-6004-A50D 2024- Mustang 5.0L Chain-drive kit

NO PART OF THIS DOCUMENT MAY BE REPRODUCED WITHOUT PRIOR WRITTEN PERMISSION OF FORD PERFORMANCE PARTS
© Ford Motor Company 2021

CRANKSHAFT AND RH CAMSHAFT COMPONENTS FOR S650 ONLY NEUTRAL POSITION

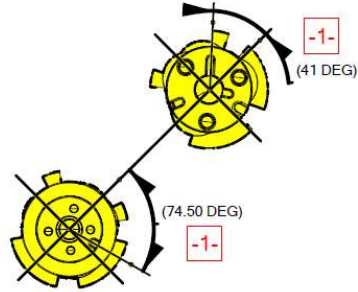

NOTE:
ROTATE CRANKSHAFT 360 DEG. FROM POSITION FOR LH CAMSHAFT INSTALLATION. THEN, WITH ADDITIONAL ROTATION, CRANKSHAFT KEYWAY MUST BE ORIENTED AT 12:00 POSITION AS SHOWN. CAMSHAFTS MUST BE CLOCKED RELATIVE TO CAM COVER RAIL AS SHOWN, PRIOR TO CAM DRIVE COMPONENTS RUNDOWN AND TIGHTENING.

NOTE:
CRANKSHAFT MUST BE ROTATED CLOCKWISE ONLY

-1- **NOTE:**
CRANKSHAFT, CAMSHAFTS, PRIMARY SPROCKETS & CHAINS, MUST BE POSITIONED TO SPECIFICATION SHOWN, PRIOR TO FASTENER INSTALLATION AND PRELIMINARY RUNDOWN.
REPRESENTS APPROXIMATE CAMSHAFT KEYWAY POSITIONS WHEN CAMSHAFTS ARE IN NEUTRAL POSITION SHOWN

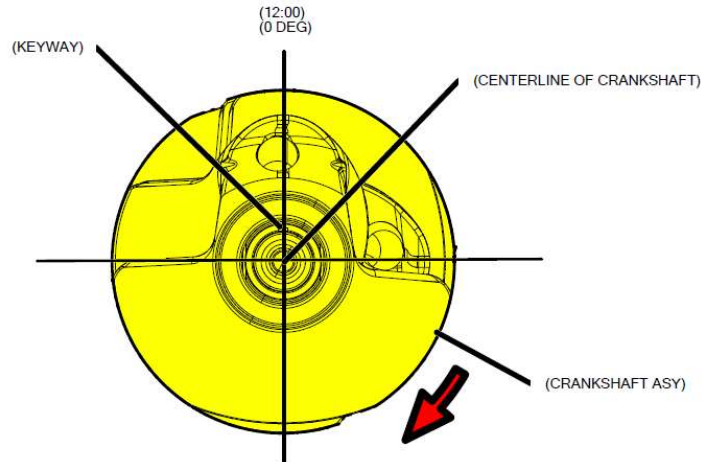

Ford Factory Shop Manual purchase options www.motorcraftservice.com



FORD PERFORMANCE

M-6004-A50D 2024- Mustang 5.0L Chain-drive kit

NO PART OF THIS DOCUMENT MAY BE REPRODUCED WITHOUT PRIOR WRITTEN PERMISSION OF FORD PERFORMANCE PARTS
© Ford Motor Company 2021

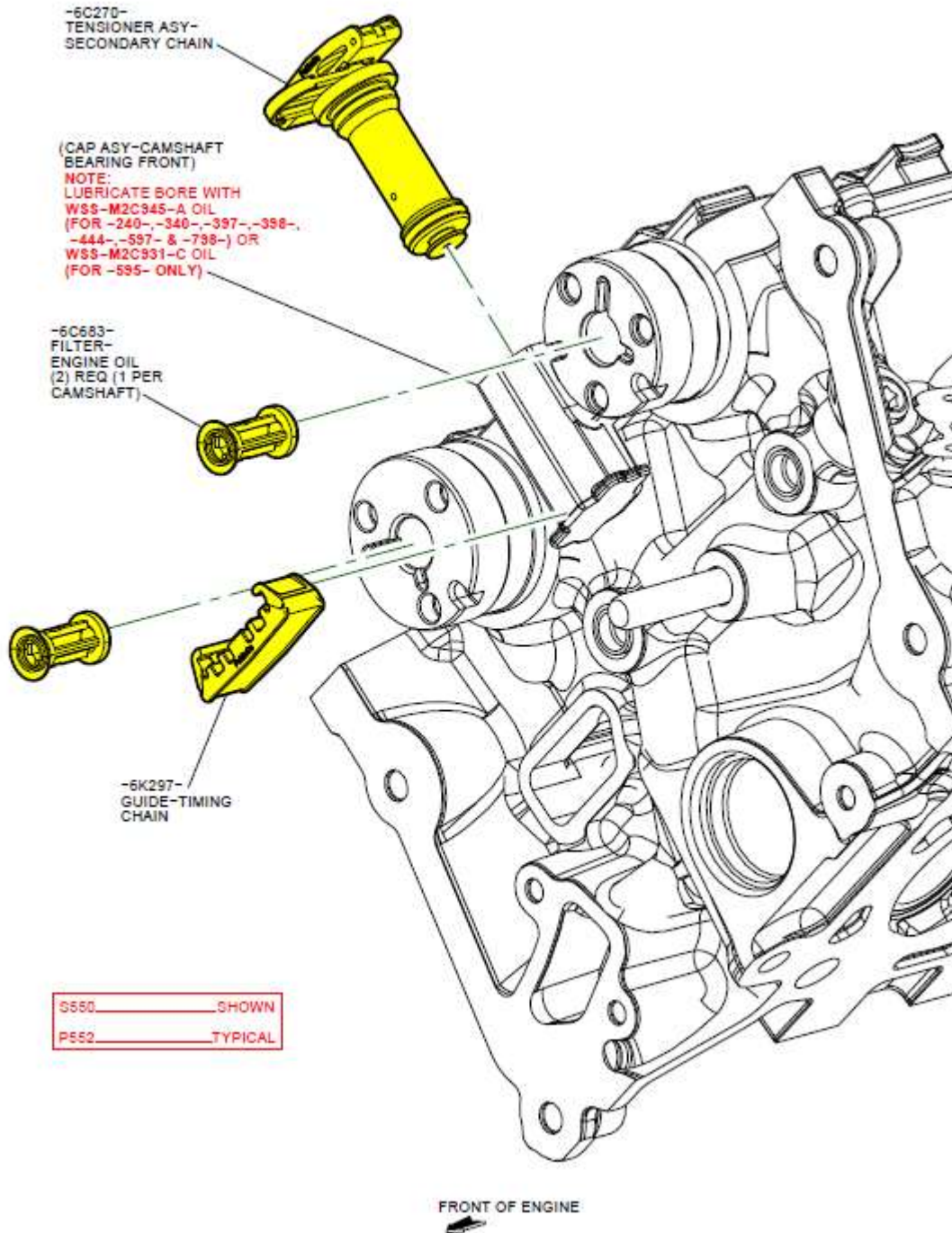

Ford Factory Shop Manual purchase options www.motorcraftservice.com



FORD PERFORMANCE

M-6004-A50D 2024- Mustang 5.0L Chain-drive kit

NO PART OF THIS DOCUMENT MAY BE REPRODUCED WITHOUT PRIOR WRITTEN PERMISSION OF FORD PERFORMANCE PARTS
© Ford Motor Company 2021

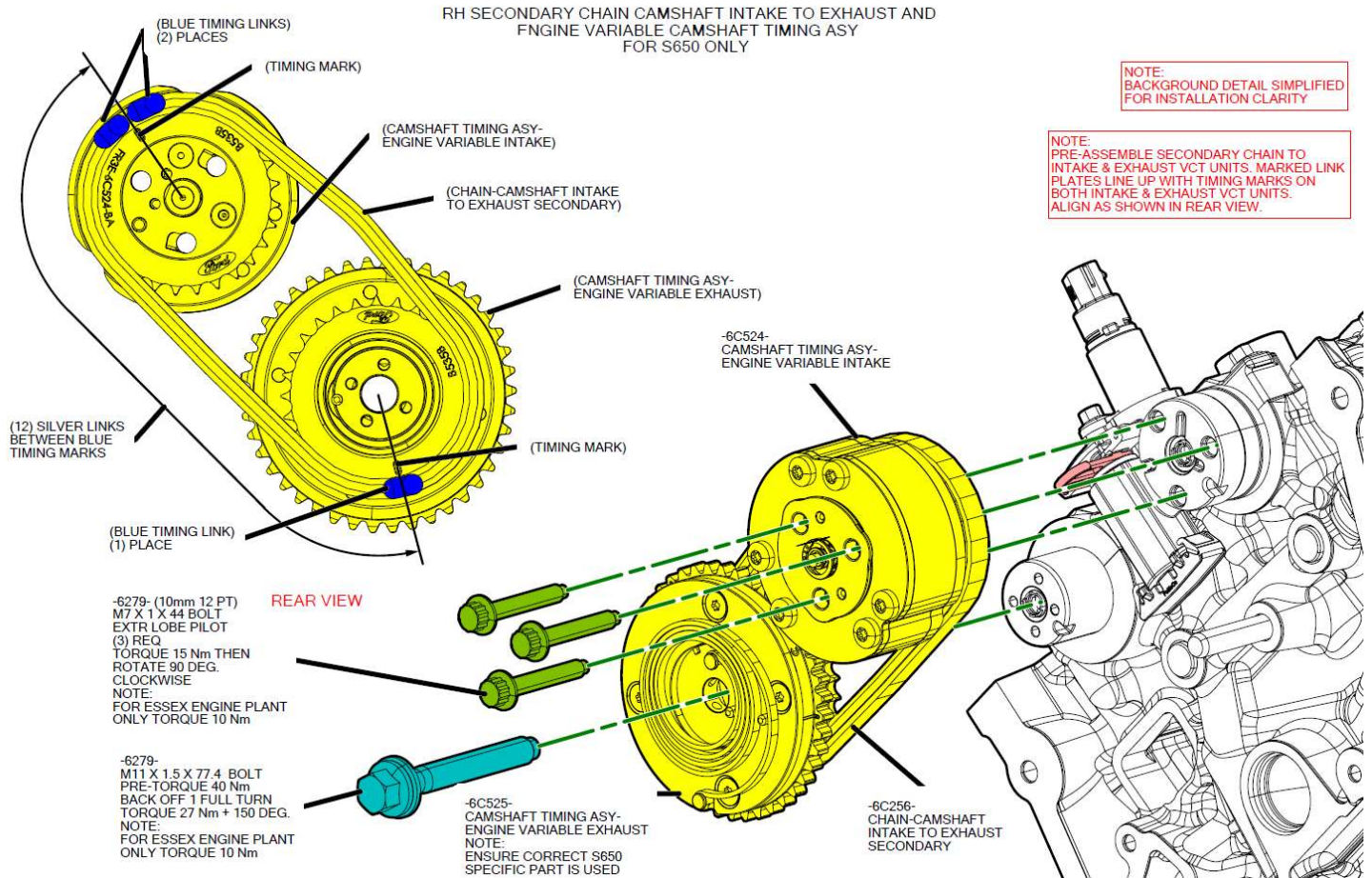

Ford Factory Shop Manual purchase options www.motorcraftservice.com



FORD PERFORMANCE

M-6004-A50D
2024- Mustang 5.0L
Chain-drive kit

NO PART OF THIS DOCUMENT MAY BE REPRODUCED WITHOUT PRIOR WRITTEN PERMISSION OF FORD PERFORMANCE PARTS
© Ford Motor Company 2021

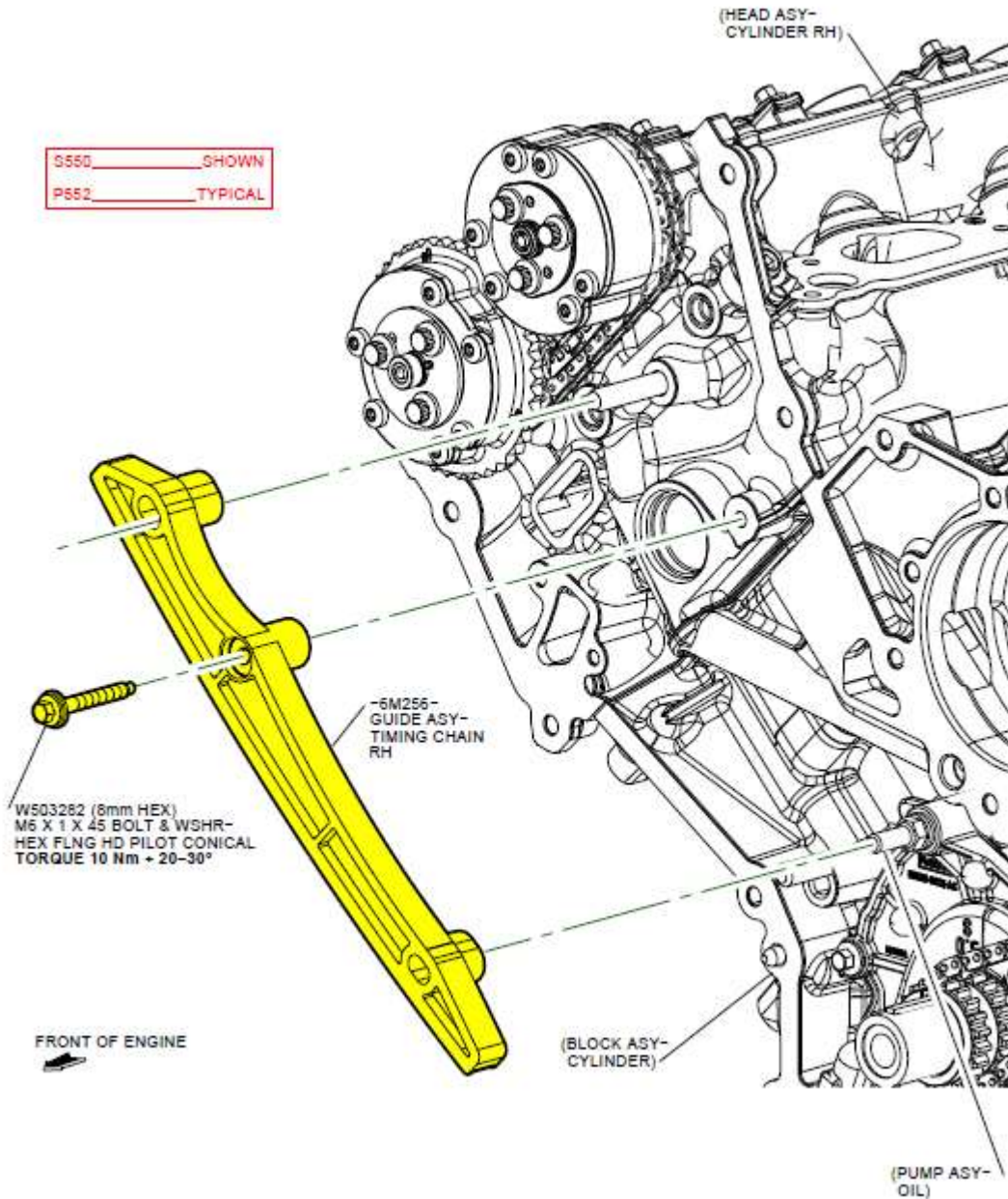

Ford Factory Shop Manual purchase options www.motorcraftservice.com



FORD PERFORMANCE

M-6004-A50D
2024- Mustang 5.0L
Chain-drive kit

NO PART OF THIS DOCUMENT MAY BE REPRODUCED WITHOUT PRIOR WRITTEN PERMISSION OF FORD PERFORMANCE PARTS
© Ford Motor Company 2021

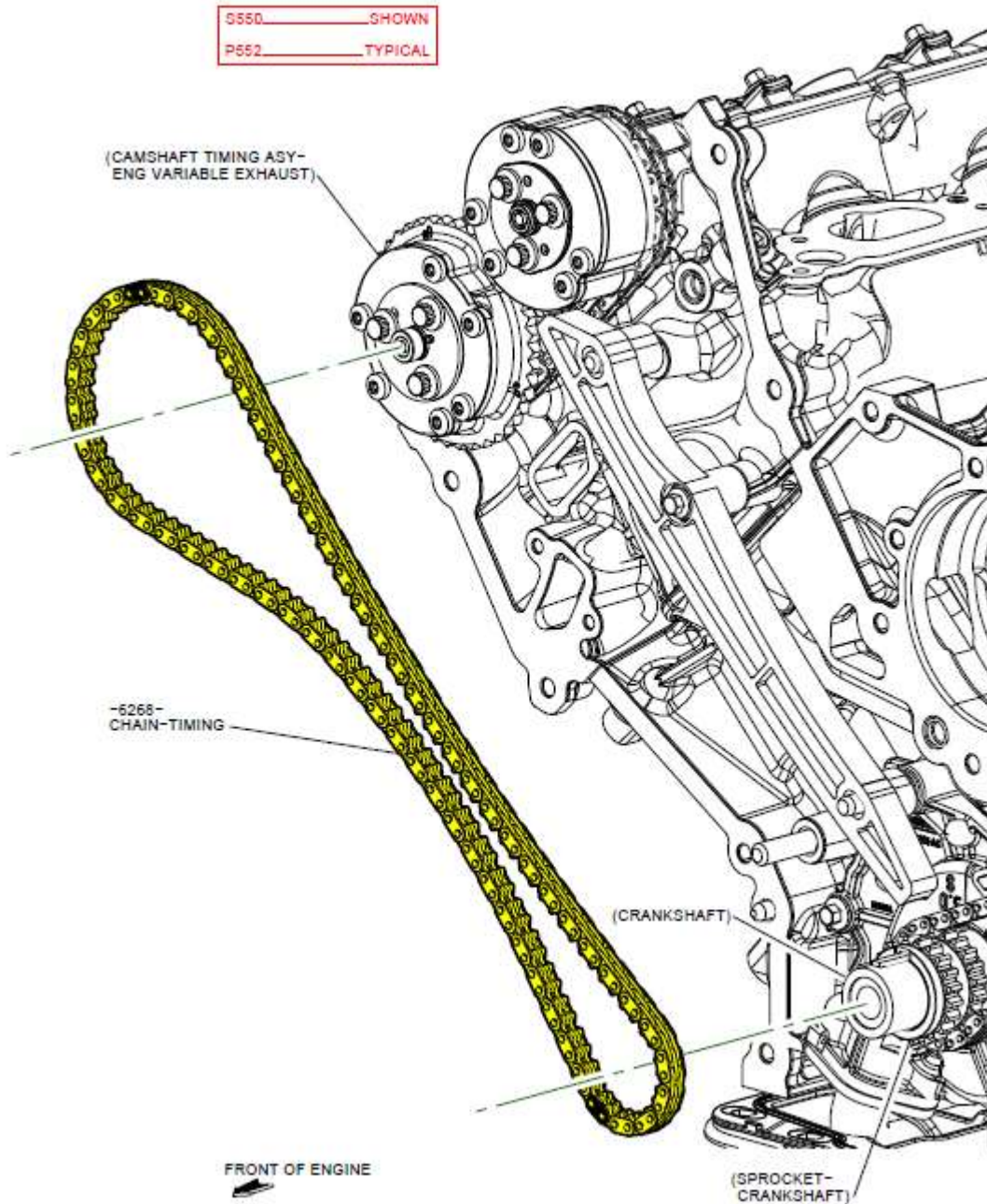

Ford Factory Shop Manual purchase options www.motorcraftservice.com



FORD PERFORMANCE

M-6004-A50D
2024- Mustang 5.0L
Chain-drive kit

NO PART OF THIS DOCUMENT MAY BE REPRODUCED WITHOUT PRIOR WRITTEN PERMISSION OF FORD PERFORMANCE PARTS
© Ford Motor Company 2021

TIMING CHAIN TENSIONER ARM ASY AND TIMING CHAIN TENSIONER RH
FOR S650 ONLY

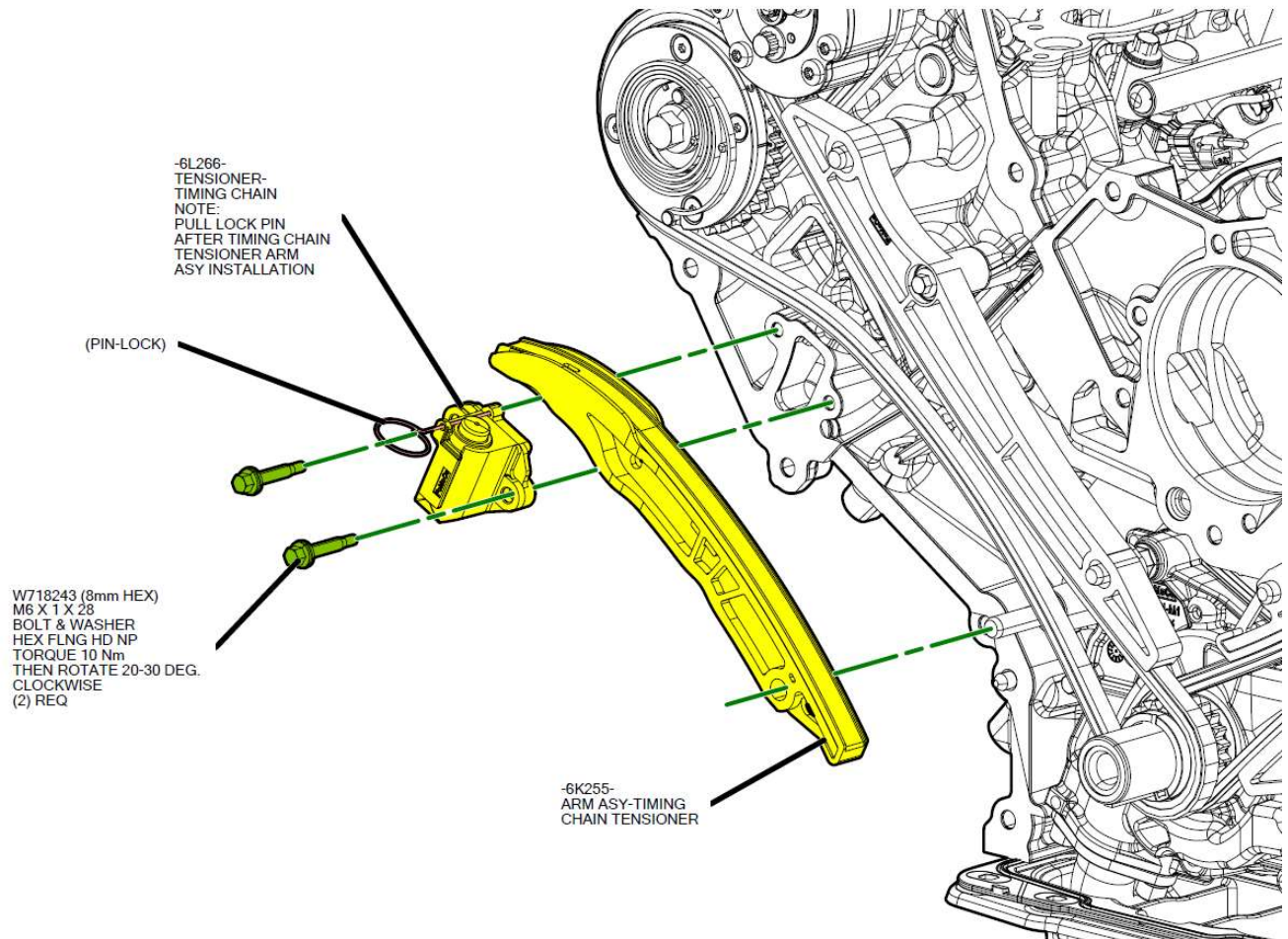

Ford Factory Shop Manual purchase options www.motorcraftservice.com



FORD PERFORMANCE

M-6004-A50D 2024- Mustang 5.0L Chain-drive kit

NO PART OF THIS DOCUMENT MAY BE REPRODUCED WITHOUT PRIOR WRITTEN PERMISSION OF FORD PERFORMANCE PARTS
© Ford Motor Company 2021

TIMING CHAIN AND ENGINE VARIABLE CAMSHAFT TIMING ASY FOR S550 ONLY

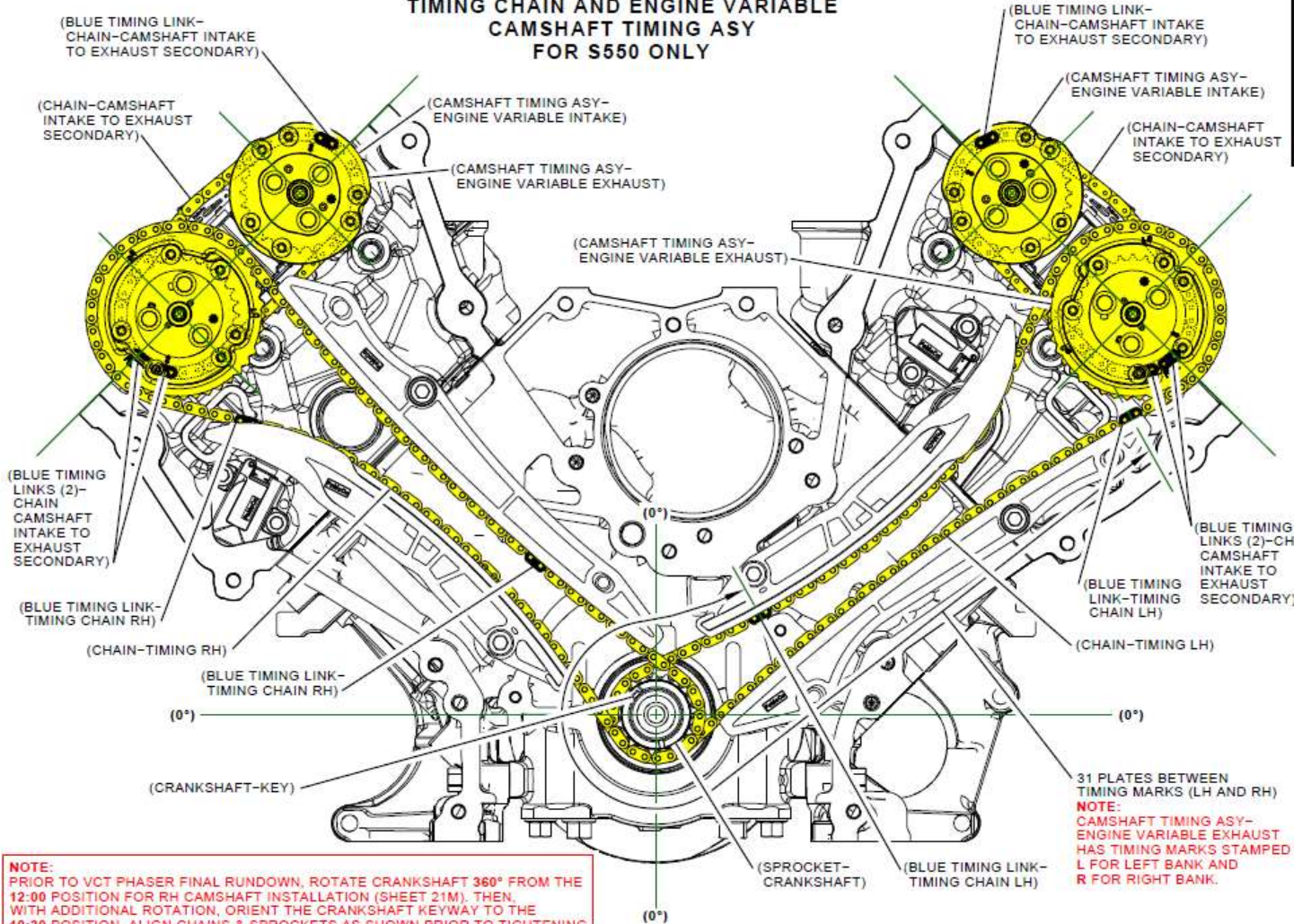

NOTE:
PRIOR TO VCT PHASER FINAL RUNDOWN, ROTATE CRANKSHAFT 360° FROM THE 12:00 POSITION FOR RH CAMSHAFT INSTALLATION (SHEET 21M). THEN, WITH ADDITIONAL ROTATION, ORIENT THE CRANKSHAFT KEYWAY TO THE 10:30 POSITION. ALIGN CHAINS & SPROCKETS AS SHOWN PRIOR TO TIGHTENING CAM DRIVE ASSEMBLY.

Ford Factory Shop Manual purchase options www.motorcraftservice.com