

NO PART OF THIS DOCUMENT MAY BE REPRODUCED WITHOUT PRIOR AGREEMENT AND WRITTEN PERMISSION OF FORD PERFORMANCE PARTS © Ford Motor Company 2020

For questions, Call the FORD PERFORMANCE Techline 1-800-367-3788

Please visit <https://www.performanceparts.ford.com> for warranty information



TABLE OF CONTENTS

Section	Topic	Page
1.0	Introduction	2
2.0	Overview	2
3.0	Included Components	2-5
4.0	Pre-Installation of Harness and Parts	6
5.0	Controls Pack Harness Installation Instructions	7-12
6.0	Ford Performance Power Distribution Box Installation	12
7.0	Fuel System	13
8.0	Wire Usage Schematics	14-16
9.0	Fuses & Relays	17
10.0	Troubleshooting Tips	17
11.0	Connector Faces	18-20
12.0	CAN Message Definition	21
13.0	Wiring Schematics (control pack, starter system, PCM pinout)	22-25

Ford Factory Shop Manual purchase options www.motorcraftservice.com



M-6017-73A 7.3L Engine Control Pack Installation Instructions

NO PART OF THIS DOCUMENT MAY BE REPRODUCED WITHOUT PRIOR AGREEMENT AND WRITTEN PERMISSION OF FORD PERFORMANCE PARTS © Ford Motor Company 2020

1.0 Introduction

This kit was developed by Ford Performance in order to allow performance enthusiasts the ability to install and run a 7.3L Crate Engine (Ford Performance P/N: M-6007-73) into any Vehicle. The automatic kit is designed to work with a Ford 10R140 transmission. Other transmissions are not supported.

Note: Cruise control is not available with this system. GPS or drive shaft speed sensors signals are suggested for vehicle speed.

2.0 Overview

This booklet provides a step by step guide for the preparation and assembly of the control pack. Please read the instructions thoroughly before starting the installation. If you have any questions, contact the Ford Performance Techline at (800) 367-3788.

3.0 Included Components

Below is a Bill of Materials included in this kit followed by detailed notes

Part #	Description
CM-12A650-AANP	2020 7.3L AUTOMATIC PCM WITH CALIBRATION
CM-14A006-A73	2020 7.3L AUTOMATIC CONTROL PACK MAIN HARNESS
CM-14A006-A73T	2020 7.3L AUTOMATIC TRANS HARNESS
CM-9474-M5087	ADAPTER GT350 TB TO GT INTAKE
CM-9600-M8B	COLD AIR INTAKE
FR3Z-12A647-B	AMBIENT AIR TEMPERATURE SENSOR
GR3Z-9E936-A	GASKET - THROTTLE BODY
HC3Z-9F836-A	ACCELERATOR PEDAL
JX6Z-12B579-A	MAF SENSOR
KR3Z-6758-A	CRANKCASE VENTILATION TUBE
KR3Z-9E926-A	THROTTLE BODY
LC3Z-9F472-F	UEGO UPSTREAM O2 SENSOR
PC-3001	PACKAGING CARTON
W500103-S437	BOLT THROTTLE BODY

3.1 Powertrain Control Module (PCM)

- The PCM is the central processing unit for engine operation. Input data/engine operation feedback is provided from each of the engine's sensors connected to the PCM via wiring leads. This input data is used to perform calculations that in turn adjust fuel quantity and spark timing according to varying driver demand (ie – accelerator pedal input).
- The PCM in this Controls Pack has a custom software and calibration dataset which were specifically developed by Ford Performance engineers to provide peak performance and reliability with the 7.3L Crate Engine (Ford Performance P/N: M-6007-73).

Ford Factory Shop Manual purchase options www.motorcraftservice.com



M-6017-73A 7.3L Engine Control Pack Installation Instructions

NO PART OF THIS DOCUMENT MAY BE REPRODUCED WITHOUT PRIOR AGREEMENT AND WRITTEN PERMISSION OF FORD PERFORMANCE PARTS © Ford Motor Company 2020

- The PCM supports CAN messages for engine speed, fuel pressure, coolant temperature, oil temperature, oil pressure, battery voltage, manifold vacuum, and gear. (see section 12 for details)

PCM Calibration Application Notes:

- The calibration provided in this PCM works with a mechanically regulated return style fuel system. See Section 7 of this manual for more information on fuel system requirements for this PCM.
- The air filter assembly with integral mass air flow sensor included with this kit must be used to achieve acceptable engine performance. Refer to Section 3.9 for more information about air inlet system requirements.

NOTE: Due to the fuel system requirement described above, installation of this PCM in ANY production vehicle will result in a no-start condition!

3.2 Control Pack Wiring Harness

- The control pack wiring harness has pre-determined lengths that will dictate the location of certain supporting components as well as the locations of fixed components on the drive train.

3.3 Accelerator Pedal Position Sensor (APPS)

- The accelerator pedal assembly includes a pair of integrated pedal position sensors (APPS1/APPS2). This pedal has electrical properties designed specifically for correct interface with PCM and is required for proper engine operation.

3.4 Fuel Supply System (Not All Components are Included)

- See section "7.0 Fuel System" of this manual for fuel pump and regulator requirements.

3.5 O2 Sensors

- One O2 sensor per cylinder bank (1 upstream) provide wide range feedback to the PCM for closed loop air fuel ratio control by measuring the quantity of oxygen present in exhaust leaving the combustion chamber.
- Tighten to 48 Nm (35 lb-ft).

NOTE: Do not splice, lengthen or otherwise modify the sensor wiring. Doing so will adversely affect the sensor performance and reliability of the signal. You may lengthen the connector leads from the harness side if necessary, by splicing, soldering and shrink wrapping the splices. The engine harness and controls package is designed to operate with the O2 sensors in the model year 2020 F-250 stock locations.

Ford Factory Shop Manual purchase options www.motorcraftservice.com

NO PART OF THIS DOCUMENT MAY BE REPRODUCED WITHOUT PRIOR AGREEMENT AND WRITTEN PERMISSION OF FORD PERFORMANCE PARTS © Ford Motor Company 2020

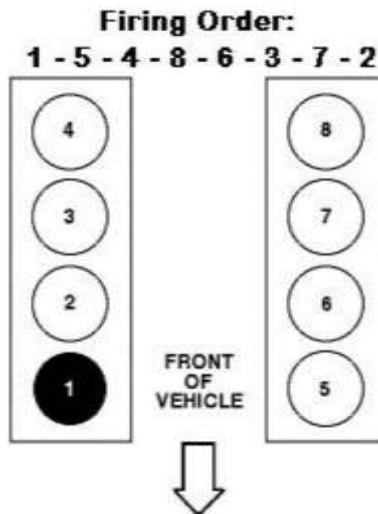

3.8 Plastic Bag of Assorted Items

- Inline fuse.
- Fuse holder.
- 6-way IP pigtail.
- Misc. hardware.



Ford Factory Shop Manual purchase options www.motorcraftservice.com

NO PART OF THIS DOCUMENT MAY BE REPRODUCED WITHOUT PRIOR AGREEMENT AND WRITTEN PERMISSION OF FORD PERFORMANCE PARTS © Ford Motor Company 2020

3.9 Air Cleaner Assembly with Integral Mass Air Flow Sensor



- A performance induction is included in the kit.
 - Throttle body and adapter plate.
NOTE: The passenger side ETB (electronic throttle body) locating pin needs to be removed from the intake manifold before adapter plate can be installed. To assure no debris contaminates the intake manifold, gaffer tape should be used to seal off the intake manifold at the throttle body flange. Using a die grinder or a pair of side cutters, the passenger side plastic locating pin needs to be cut off flush. A file can be used to make a flush surface if the cut is not flat.
 - Induction tube with integrated MAF sensor.
 - Air filter.
 - Air Filter enclosure.
- You must replace the original throttle body that is installed on the engine (as shipped), with the unit included in the kit for proper operation.
- The installation of the air filter enclosure is optional and may be modified.

NO PART OF THIS DOCUMENT MAY BE REPRODUCED WITHOUT PRIOR AGREEMENT AND WRITTEN PERMISSION OF FORD PERFORMANCE PARTS © Ford Motor Company 2020

3.10 Ambient Air Temperature (AAT)



- The AAT must be installed in the vehicle forward of the radiator or other heat exchangers.
- The installation location must be in the flow of fresh air to provide optimum performance as it effects the calculation of the delivered spark and fuel.

3.11 Controls Pack Wiring Assembly

- Connects to vehicle battery and inline connector on engine harness.
- Contains Ford Performance Power Distribution Box (FPPDB) and high power inline fuse.
- Electrical connections to Accelerator Pedal (APPS).
- Wire leads for Ignition Switch & Starter.
- Data Link Connector for reading Diagnostic Trouble Codes (DTCs).
- Check Engine/Malfunction Indicator Lamp (MIL) for visual indication of engine control system fault code presence.
- MIL will stay illuminated when the ignition is ON and the engine is NOT running; therefore this condition does not indicate a system fault; Not all DTCs will cause the MIL to illuminate.
- only the MIL included in this kit will illuminate if a fault exists.

4.0 Pre-Installation of Harnesses and Parts

The following is a list of key factors to consider before any of the installation takes place:

- PCM mounting location is limited by the length of the PCM lead of the engine harness (located on the right front corner of the engine). The PCM connector lead measures 22 inches from the lower edge of the right valve cover. This will dictate the location of where the PCM will need to be mounted.
- Ford Performance Power Distribution Box must be mounted, in the engine compartment, within 60 inches of the vehicle battery or positive battery post if you have a trunk mounted battery as dictated by the battery positive and ground lead lengths of the controls pack wiring harness.
- Lay out the harness and components first in order to ensure that the wiring leads will reach everywhere you intend them to. This is a good check before you drill any holes or mount any components!

Ford Factory Shop Manual purchase options www.motorcraftservice.com

NO PART OF THIS DOCUMENT MAY BE REPRODUCED WITHOUT PRIOR AGREEMENT AND WRITTEN PERMISSION OF FORD PERFORMANCE PARTS © Ford Motor Company 2020

Suggested Battery Cable Diagram

Connect the Battery positive to the starter and alternator.

Ground the engine to the chassis.

NOTE: Pay close attention to the vehicle grounds. Many times, electrical issues can be traced back to insufficient ground circuits. Ensuring your vehicle is well grounded now, will save you time and frustration later.

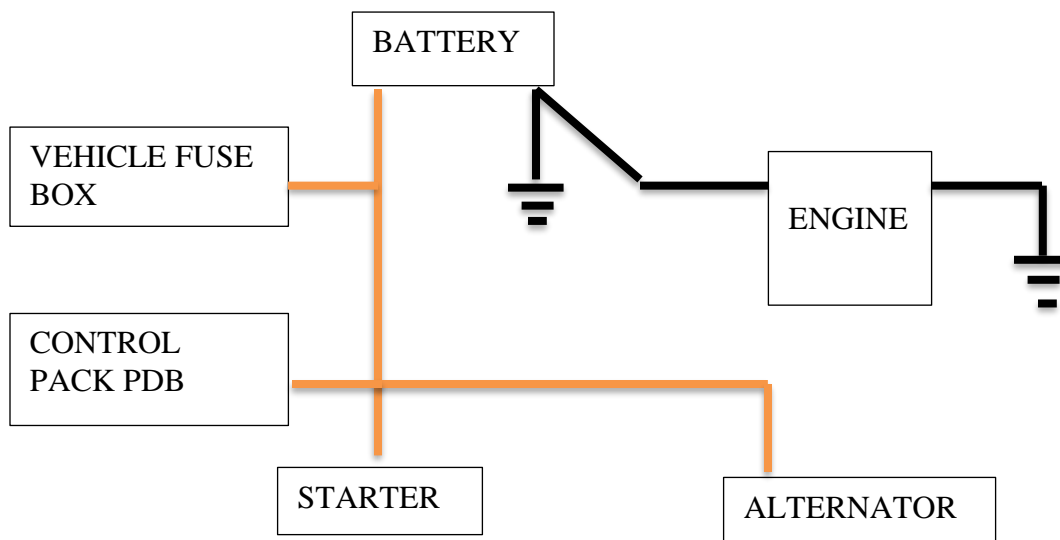

Ford Factory Shop Manual purchase options www.motorcraftservice.com



FORD PERFORMANCE

M-6017-73A 7.3L Engine Control Pack Installation Instructions

NO PART OF THIS DOCUMENT MAY BE REPRODUCED WITHOUT PRIOR AGREEMENT AND WRITTEN PERMISSION OF FORD PERFORMANCE PARTS © Ford Motor Company 2020

5.0 Control Pack Harness Installation Instructions

Item	Connector #	Description		Item	Connector #	Description
A	-	Ford Performance Power Distribution Box		O	C132	Ambient Air Temperature Sensor
B	-	Ground		P	C400	Intercooler Pump
C	C160A	Inline to IP Pigtail		Q	C90	PCM Trans connector
D	C2040	Accelerator Pedal Position Sensor		R	C1A	Inline to Controls Pack Harness
E				S	C1571	O2 sensor Upstream-RH
F	C251	Data Link Connector & MIL		T	C1572	O2 sensor Upstream-LH
G	-	Optional EPAS connection		U	C141	Not used
H	-	Starter Solenoid		V	C142	Not Used
I	-	Cooling Fan Feed		W	C168A	Automatic transmission Bulkhead (auto only)
J	C146	Auxiliary Inline to Engine		X	C8	Aux Module (not used)
K	C1B	Inline to Trans Harness		-	-	-
L	C175B	PCM vehicle connector		-	-	-
M	C128	Mass Air Flow Sensor		-	-	-
				-	-	-

Table 1 – Summary of Controls Pack Connectors

Figure 1a - 2020 7.3L AUTOMATIC CONTROL PACK MAIN HARNESS

Ford Factory Shop Manual purchase options www.motorcraftservice.com



FORD PERFORMANCE

M-6017-73A 7.3L Engine Control Pack Installation Instructions

NO PART OF THIS DOCUMENT MAY BE REPRODUCED WITHOUT PRIOR AGREEMENT AND WRITTEN PERMISSION OF FORD PERFORMANCE PARTS © Ford Motor Company 2020

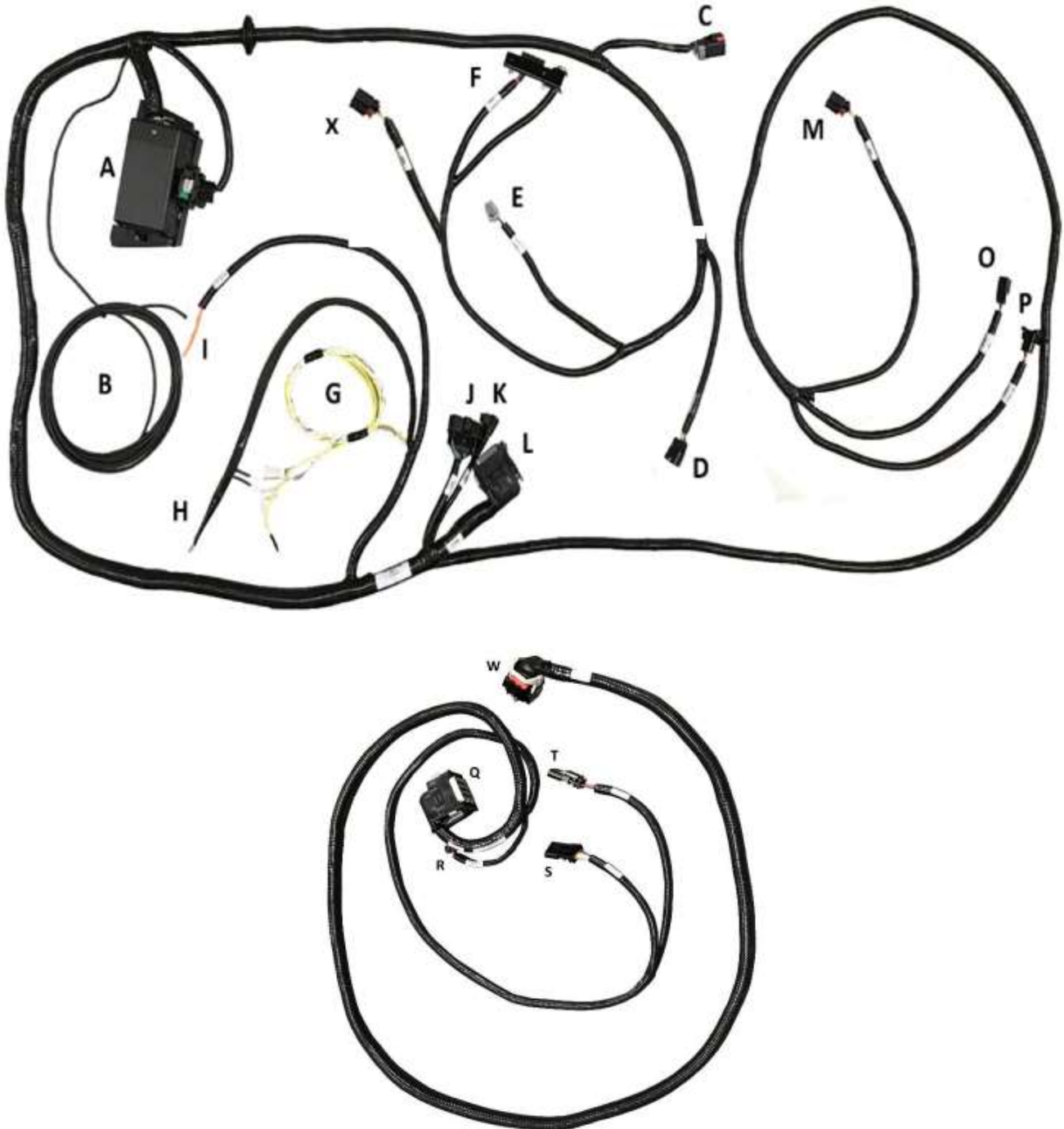

Figure 1b – 2020 7.3L AUTOMATIC TRANS HARNESS

5.1 Controls Pack Harness Installation Instructions

Ford Factory Shop Manual purchase options www.motorcraftservice.com



M-6017-73A 7.3L Engine Control Pack Installation Instructions

NO PART OF THIS DOCUMENT MAY BE REPRODUCED WITHOUT PRIOR AGREEMENT AND WRITTEN PERMISSION OF FORD PERFORMANCE PARTS © Ford Motor Company 2020

NOTE: To avoid electrical shock and/or damage to sensitive electrical control system components, before beginning any work, remove the vehicle's negative battery terminal and place a rag or towel between it and the battery negative post. **The negative battery terminal is not to be reinstalled until the last step of installation.**

1. Identify proper mounting location for the PCM, Power Distribution Box (Item A) & inline fuse holder. Locate the PCM connector (Item L) on the engine harness and start there.
2. Plug the PCM vehicle connector (item L), from the controls pack harness and the PCM trans connector (item Q) from the transmission harness into the PCM; once plugged-in, use a zip-tie to tie the bundle of wires exiting each connector back together. Route the transmission harness so that all upstream O2 sensor connectors (items S and T) are able to reach their corresponding sensors. Connect the O2 sensors. In the steps that follow, we will be repeating this process of using zip-ties to piggy-back/tie the harness to the existing engine harness approximately every 200 mm along the engine harness.
3. Connect the in-line connector (item J) from the controls pack harness to the mating connector on the engine harness.
4. Connect mass air flow (MAF) sensor connector (item M), ambient air temperature (AAT) sensor connector (item O) to their respective locations, being sure to avoid any pinch-points or exhaust hot-spots.
5. Connect blunt-cut orange 10 AWG cooling fan lead and starter lead eyelet (item H) to their respective locations.
6. The grommet needs to be properly installed in the firewall of your vehicle so as to protect the Controls Pack Harness routing that passes through to the passenger compartment. All connections previously mentioned are located under hood; all connections mentioned from this point on are located in the passenger compartment.
7. Identify proper mounting location for the accelerator pedal and ignition switch (purchased separately).
8. Identify mounting location for the bracket with OBDII connector and Malfunction Indicator Light.
9. Connect the ground eyelet (item B) to a reliable ground point on the chassis or engine block, away from dirt and water.
10. Route the IP pigtail (item C) to approximately the base of the steering wheel to be connected later.
11. Connect the APPS connector (item D) to the accelerator pedal.
12. Locate the 6-way I/P Pigtail connector with blunt leads (item C) and continue to Section 6.

* Removal Procedures for Unused Connectors:

If 100% sure connector is not currently needed and will not be needed in the future, cut routing leading-up to unused connector and individually heat shrink each wire herein. To ensure that the wires are completely isolated from one another and the outside environment, you may also want to wrap the heat-shrunk wire in electrical tape to provide an additional layer of protection from moisture and dirt.

Ford Factory Shop Manual purchase options www.motorcraftservice.com

NO PART OF THIS DOCUMENT MAY BE REPRODUCED WITHOUT PRIOR AGREEMENT AND WRITTEN PERMISSION OF FORD PERFORMANCE PARTS © Ford Motor Company 2020

5.2 6-way I/P Pigtail Connection Details (This is connector C160B which plugs into C160A previously mentioned, it is the connector with blunt leads coming from it)



The 6-way pigtail is to be connected according to the chart below. See also the diagrams on the following pages for illustrations of wire connection points, based on the ignition/starter switches that you intend to use. Setup A uses separate toggle switches for ignition and starter inputs, while Setup B uses an ignition cylinder with a key.

Cavity	Lead Label	Wire Color	Description
1	Fuel Pump Relay Out	GN	Provides +12V to the fuel pump
2	-	-	-
3	Starter Motor Request (SMR)	Light Blue	Apply +12V to send a request to the PCM to energize the starter solenoid
4	-	-	-
5	Ignition Relay Trigger	Light Green	Apply +12V to energize the ignition relay/wake-up the system
6	-	-	-

Locate each of the blunt leads. This is where you will need to make all of the soldered connections for the harness. Before soldering any wires, however, you must first decide which set-up you will pursue by referencing Set-up A and Set-up B on pages 15 and 16.

Connect the following REQUIRED blunt leads as follows:

Blunt Lead 1 – Fuel Pump Relay Out (Dark Green): Connect to fuel pump positive. Separate ground for fuel pump must be provided. Note the fuel pump will start running any time key is on, then if you don't start the engine, the computer will turn it off after a couple of seconds.

Ford Factory Shop Manual purchase options www.motorcraftservice.com



M-6017-73A 7.3L Engine Control Pack Installation Instructions

NO PART OF THIS DOCUMENT MAY BE REPRODUCED WITHOUT PRIOR AGREEMENT AND WRITTEN PERMISSION OF
FORD PERFORMANCE PARTS © Ford Motor Company 2020

Blunt Lead 3 – Starter Motor Request (Light Blue):

Set-up A:

Connect to input node of starter momentary switch so that 12 volts is provided when engine starting is requested.*

Set-up B:

Connect to 'Start' output node of ignition cylinder so that 12 volts is provided when engine starting is requested.*

Blunt Lead 5 – Ignition Relay Trigger (Light Green):

Set-up A:

Connect this wire to the output side of the ignition toggle switch so that 12 volts is provided when the key is in the 'Start' (cranking) and 'Run' positions. It is imperative that this circuit be reliable, the PCM will interpret an intermittent voltage on this signal as a request to shut down the engine! (Hint, if your engine shuts down after a hard launch check here first).

Set-up B:

Connect to the 'Start/Run' output node of ignition cylinder so that 12 volts is provided when engine starting is requested. It is imperative that this circuit be reliable, the PCM will interpret an intermittent voltage on this signal as a request to shut down the engine! (Hint, if your engine shuts down after a hard launch check here first).

Once all of the blunt lead connections have been soldered onto their appropriate location, insert the 6-way I/P Pigtail connector into item C.

*** Important Note on the Starting System**

This kit includes connections and installation instructions for PCM controlled engine starting; however, it is not required that the customer utilize this option. Customers may choose to use their existing non-PCM controlled starting system if desired. If non-PCM controlled starting is used, unused blunt leads should be cut to approximately 2" length and sealed using heat shrink.

6.0 Ford Performance Power Distribution Box Installation

- 6.1 Before you start, you should have your two battery cables at hand (purchased separately, 4 AWG recommended), one from battery to fuse holder, the other one from fuse holder to FPPDB.
- 6.2 Carefully remove the nut and washers on both terminals of the in-line fuse holder and set aside.
- 6.3 Use one of your battery cables and place the eyelet onto one of the two in-line fuse holder terminals, then one of the washers, and then tighten down with one of the two nuts.
- 6.4 Locate the power terminal of the side of FPPDB, notice there is a battery positive blunt lead eyelet already attached to it. Attach the other eyelet to this power terminal by tightening the nut down on top of the eyelet. The order of installation on the power terminal should be a washer, the battery cable eyelet, then the blunt lead eyelet, another washer, and then the nut. Avoid sharp points and using zip-ties to secure the cable (approximately every 200 mm) along the way. **DO NOT CONNECT ANYTHING TO THE BATTERY YET.**
- 6.5 Place the Buss 250A fuse onto the fuse holder terminals.
- 6.6 On the opposite in-line fuse holder terminal, place one eyelet of your second battery cable, then the other remaining washer, and then tighten down with the remaining nut.
- 6.7 Close the cover of the in-line fuse holder.
- 6.8 Being careful not to inadvertently complete the circuit, connect the opposite end of the battery cable to the positive terminal of the vehicle battery.

Ford Factory Shop Manual purchase options www.motorcraftservice.com

NO PART OF THIS DOCUMENT MAY BE REPRODUCED WITHOUT PRIOR AGREEMENT AND WRITTEN PERMISSION OF FORD PERFORMANCE PARTS © Ford Motor Company 2020

6.9 Attach the ground blunt lead to the negative battery terminal (you will need to provide the eyelet). Verify that you have a good (dry and clean) ground path from the battery negative post to the chassis ground. In general, the resistance from the battery ground to this chassis location should be less than 0.1 ohm.

7.0 Fuel System

The PCM is calibrated for a return style fuel system as shown below.

- Use only AN type fuel fitting to interface with OEM fuel rail.
- Fuel pump must be capable of 160 liters per hour flow at 60 psi.

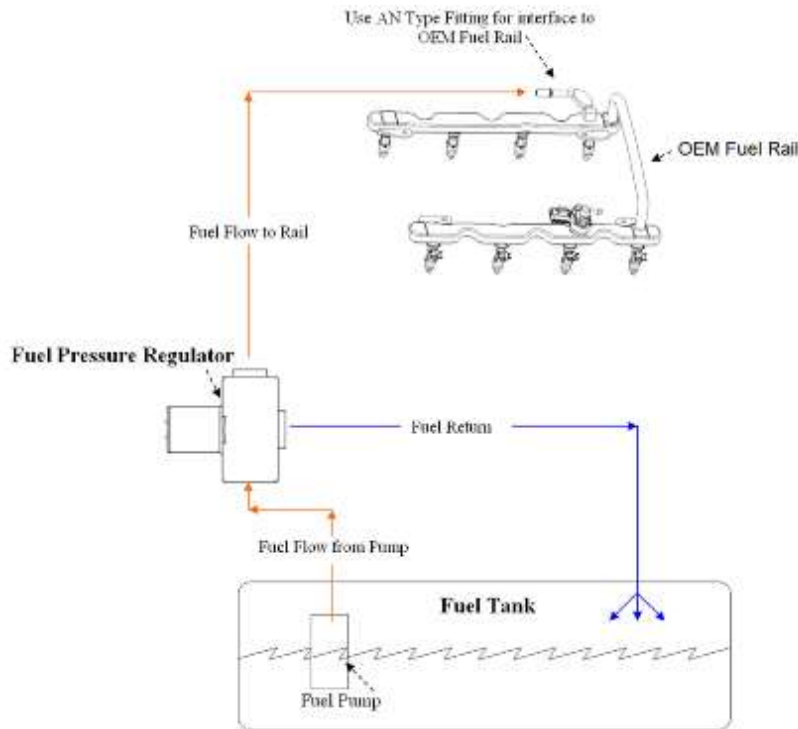

Fuel pump requirements: 160L/Hr minimum at 60 psi

Fuel pump location

A common and often overlooked problem is the location of the fuel pump or pumps. Optimally, the fuel pump should be mounted IN THE TANK to reduce the possibility of pump cavitation. Cavitation is essentially localized boiling caused by a reduction in pressure, generally occurring on the inlet side of a pump. This localized boiling results in fuel vapor bubbles which will reduce the volume of fuel the pump is capable of delivering to the engine. Any reduction in pressure or increase in temperature at the inlet side of the pump increases the chances that cavitation will occur. For this reason, it is always best to either have the pump inside the tank immersed in fuel or (in the case of an external pump) gravity fed, which will increase the pressure on the inlet side of the pump. If the fuel pump has to "pull" the fuel, this will result in a reduction in pressure at the fuel pump inlet potentially allowing cavitation and, thus, vapor bubbles to develop. These vapor bubbles are then drawn into the fuel pump and exit the high-pressure side of the fuel pump as compressed vapor. They travel the entire length of the fuel system and are expelled through the fuel injector. This can cause issues

Ford Factory Shop Manual purchase options www.motorcraftservice.com



FORD PERFORMANCE

M-6017-73A

7.3L Engine Control Pack Installation Instructions

NO PART OF THIS DOCUMENT MAY BE REPRODUCED WITHOUT PRIOR AGREEMENT AND WRITTEN PERMISSION OF
FORD PERFORMANCE PARTS © Ford Motor Company 2020

ranging from stumbles and hesitations to engine damage due to insufficient fuel delivery and lean A/F ratios. Sometimes this problem can characterize itself by only appearing when the weather gets warmer, which can confound the diagnosis of the issue. In certain cases, it may seem to only develop when driving on certain surfaces, because pavement reflects more heat than an off-road 4x4 trail. Remember, more heat and lower pressure on the inlet side of the pump means a greater chance of cavitation, which is to be avoided whenever possible.

If you are using an external mounted fuel pump, you should run a very coarse (typically around 100 micron) filter on the inlet side of the fuel pump, and a finer (typically around 10 micron) filter on the outlet side of the pump. A paper filter is NOT recommended on the inlet of the fuel pump because it can cause a restriction in fuel flow which, as mentioned previously, can lead to cavitation.

Warning: It is highly recommended that an inertia switch is incorporated into the fuel pump wiring to turn off the fuel pump in event of an accident.

8.0 Wire Usage Schematics

The following two pages detail the two most common wiring configurations—please choose one to complete installation of your controls pack kit. You will need to provide a 12V Hot At All Time wire yourself.

Ford Factory Shop Manual purchase options www.motorcraftservice.com

NO PART OF THIS DOCUMENT MAY BE REPRODUCED WITHOUT PRIOR AGREEMENT AND WRITTEN PERMISSION OF FORD PERFORMANCE PARTS © Ford Motor Company 2020

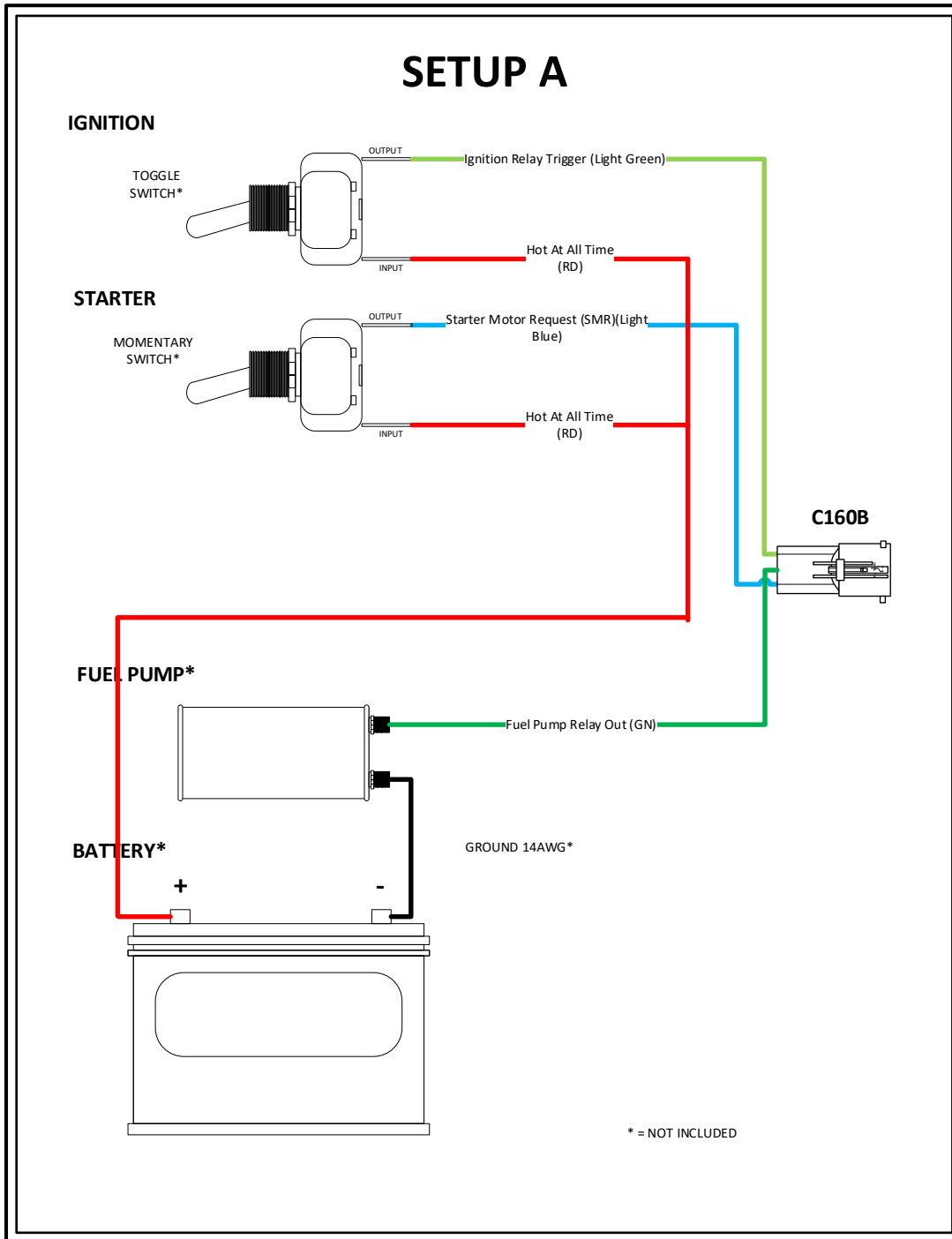

Ford Factory Shop Manual purchase options www.motorcraftservice.com



FORD PERFORMANCE

M-6017-73A 7.3L Engine Control Pack Installation Instructions

NO PART OF THIS DOCUMENT MAY BE REPRODUCED WITHOUT PRIOR AGREEMENT AND WRITTEN PERMISSION OF FORD PERFORMANCE PARTS © Ford Motor Company 2020

SETUP B

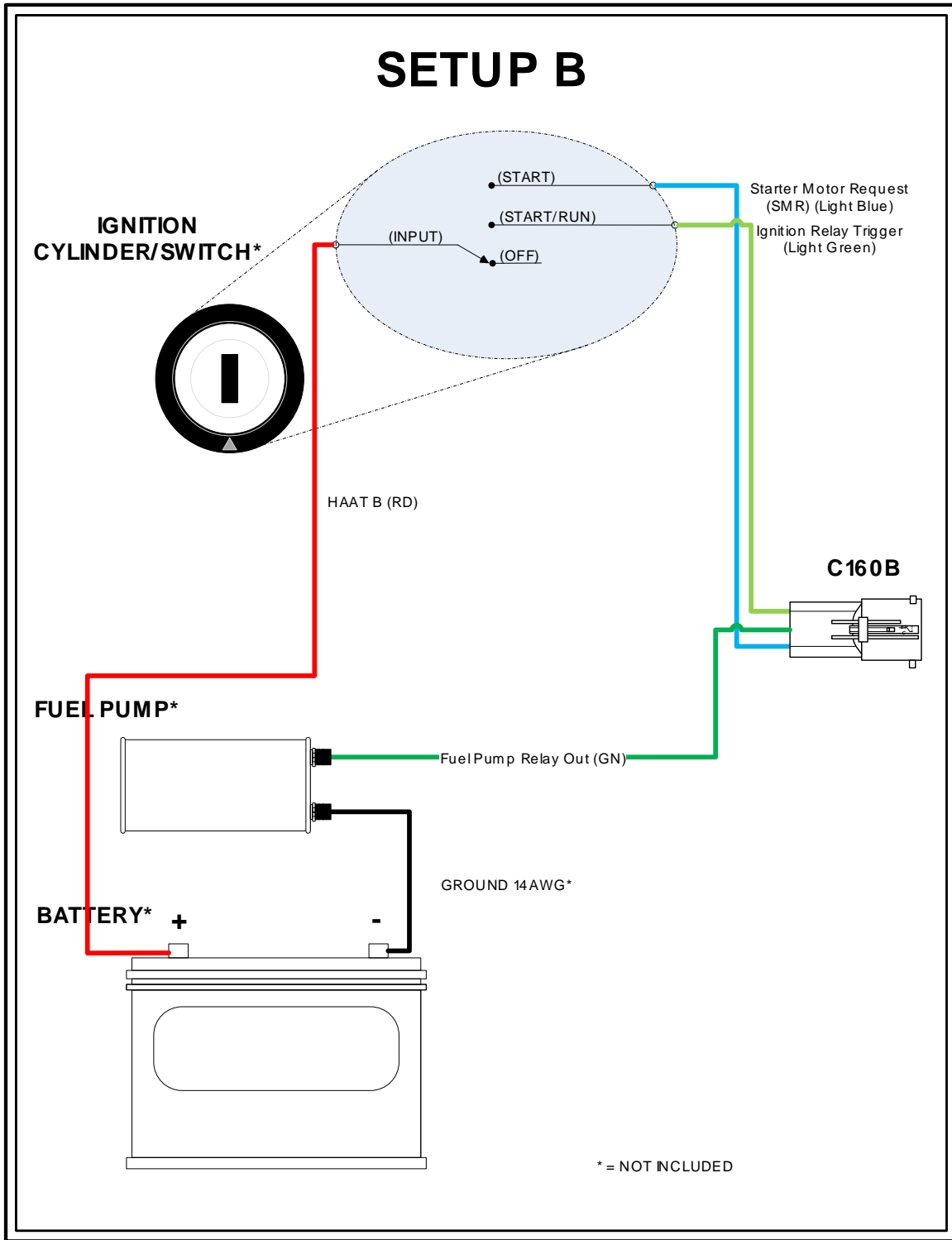

Ford Factory Shop Manual purchase options www.motorcraftservice.com



FORD PERFORMANCE

M-6017-73A

7.3L Engine Control Pack Installation Instructions

NO PART OF THIS DOCUMENT MAY BE REPRODUCED WITHOUT PRIOR AGREEMENT AND WRITTEN PERMISSION OF FORD PERFORMANCE PARTS © Ford Motor Company 2020

9.0 Fuses & Relays

- This diagram outlines the fuses and relays included in the controls pack wiring harness, and the function of each.
- NOTE: Do NOT replace any of the fuses with a higher value than those specified below.

ID: PDB
Name: Component ID/Values

Component ID	Type	Value	Name
JC1	J-Case Fuse	50A	PCM Relay Feed
JC2	J-Case Fuse	50A	Cooling Fan Relay Feed
JC3	J-Case Fuse	30A	Starter Relay Feed
JC4	J-Case Fuse	40A	Fuel Pump Relay Feed
JC5	J-Case Fuse	40A	Ignition Relay Feed
JC7	J-Case Fuse	NOT USED	NOT USED
JC8	J-Case Fuse	NOT USED	NOT USED
F1	MiniFuse	20A	VPWR1
F2	MiniFuse	20A	VPWR2
F3	MiniFuse	15A	VPWR3
F4	MiniFuse	15A	VPWR4
F5	MiniFuse	10A	Ignition Switched A
F6	MiniFuse	10A	Ignition Switched B
F7	MiniFuse	15A	ICP
F8	MiniFuse	15A	Ignition Switched C
F9	MiniFuse	15A	VPWR6
F10	MiniFuse	10A	HAAT A
F11	MiniFuse	10A	HAAT B
R1	Power Mini Relay	70A	PCM Relay
R2	Power Mini Relay	70A	Cooling Fan Relay
R3	High Current Micro Relay	40A	Starter Relay
R4	High Current Micro Relay	40A	Fuel Pump Relay
R6	High Current Micro Relay	40A	Ignition Relay

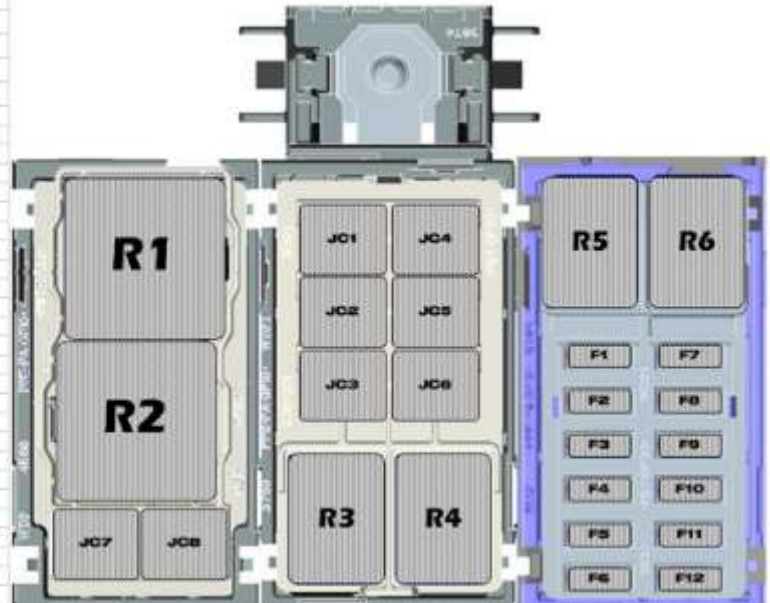

10.0 Troubleshooting tips:

The following troubleshooting tips are intended for you to run a few quick tests to roughly determine what the issues are before calling the Ford Performance Techline or to find a solution yourself:

- Double check all the grounds. The wirings included in this kit is extremely sensitive to ground issues. Secure all the connections from the chassis grounds to the battery's negative post. Do a continuity test with your multimeter between all your ground terminals and battery ground.
- Check all reference voltages, confirm they are not shorted. Use a multimeter to measure the voltage at each sensor. It should read 5V.
- If none of the sensors or components have power, check the ignition switch, ignition relay R6, and PCM relay R1 wiring. It should have 12V at both relay outputs with the ignition on. This is fused via F5 and F1 separately. Use a multimeter to measure the voltage at F5 and F1, to confirm that it is 12V. Use the small holes on the mini fuses to probe and measure voltage.
- If the sensor and relay measured voltages are correct, but the engine does not crank, check for the starter switch and starter relay R3 wiring. It should have 12V at the relay output when the ignition is in the crank position. Measure the voltage at the starter solenoid leads from harness (disconnect from starter). 12V is expected during cranking at these leads as well.
- If your engine only cranks, but does not fire, a fuel system malfunction could be the cause. First check that there is 12V at fuel pump +, and all injectors when the key is in the on position. Then, measure the pressure at the fuel rail, it should increase when the key is cycled to on.

Ford Factory Shop Manual purchase options www.motorcraftservice.com

NO PART OF THIS DOCUMENT MAY BE REPRODUCED WITHOUT PRIOR AGREEMENT AND WRITTEN PERMISSION OF FORD PERFORMANCE PARTS © Ford Motor Company 2020

11.0 Connector Faces

MAF/IAT
Mass Air Flow
Intake Air Temperature
Sensor
(Key B)

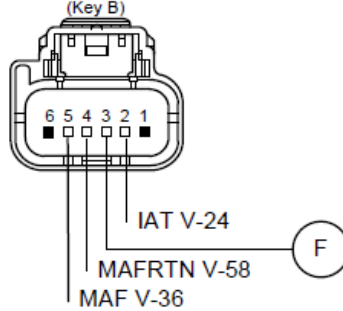

APPS
Accelerator Pedal
Position Sensor
(Key A)

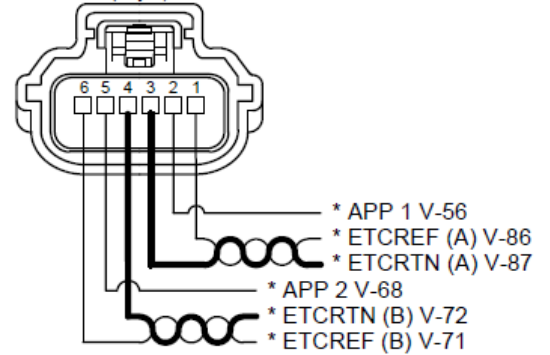

Intercooler Pump (used only with supercharger)

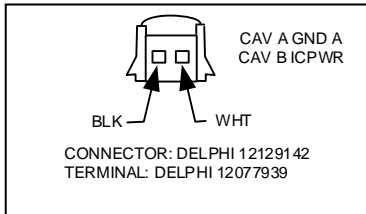

AAT
Ambient Air
Temperature
(Key B)

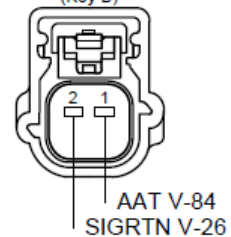

Ford Factory Shop Manual purchase options www.motorcraftservice.com

M-6017-73A 7.3L Engine Control Pack Installation Instructions

NO PART OF THIS DOCUMENT MAY BE REPRODUCED WITHOUT PRIOR AGREEMENT AND WRITTEN PERMISSION OF FORD PERFORMANCE PARTS © Ford Motor Company 2020

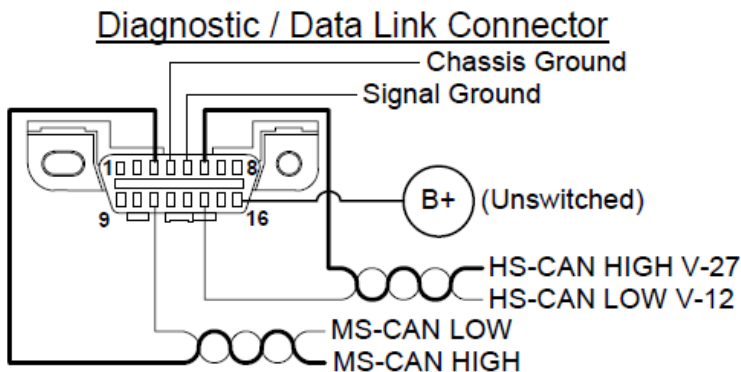
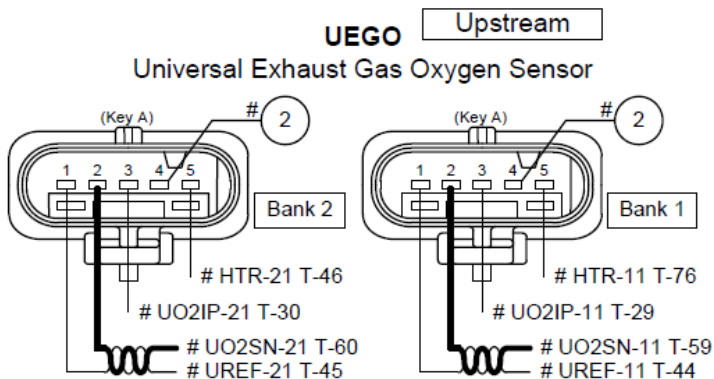

C160B inline to C160A

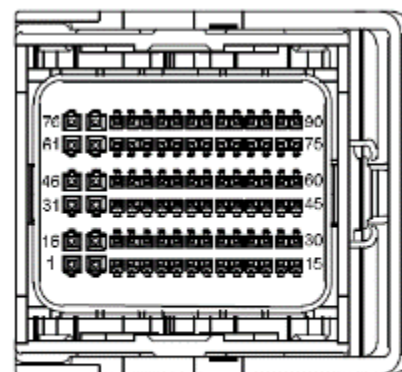
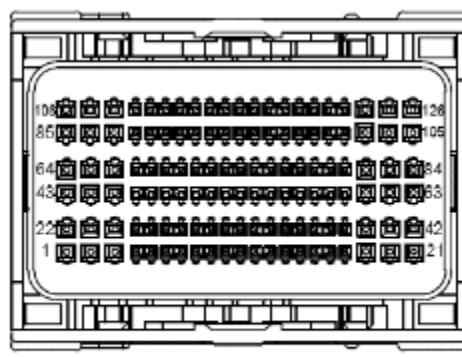
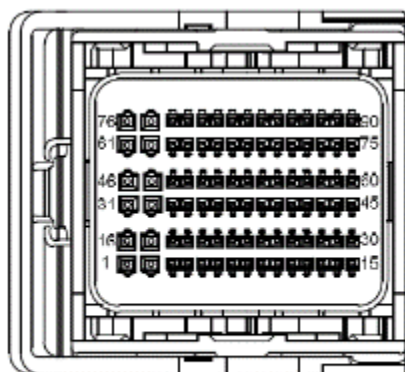
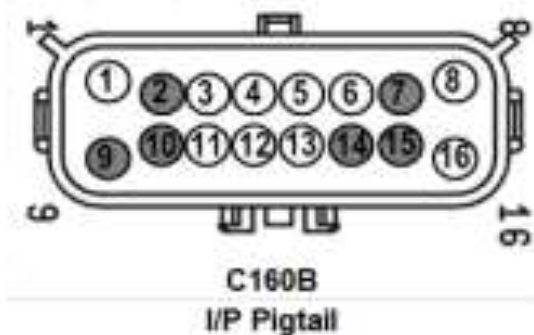

Ford Factory Shop Manual purchase options www.motorcraftservice.com



FORD PERFORMANCE

M-6017-73A 7.3L Engine Control Pack Installation Instructions

NO PART OF THIS DOCUMENT MAY BE REPRODUCED WITHOUT PRIOR AGREEMENT AND WRITTEN PERMISSION OF FORD PERFORMANCE PARTS © Ford Motor Company 2020

A10R140 Bulkhead

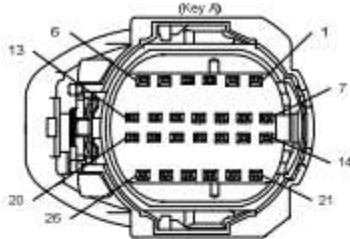

A10R140 (AT)

Mechanical Park_B

From Bulkhead Pin / Function	To PCM Cavity / Pin
1 TSS	T-38
2 ISS A	T-37
3 ISS B	T-54
4 OSS	T-51
5 TR-P1	T-36
6 TR-P2	T-55
7 VREF A	T-50
8 VREF B	T-35
9 TSPC 1	T-2
10 Run/Start	Run/Start Power PDJB
11 TSPC 2	T-1
12 RESERVED	
13 TFT	T-42
14 PC_1 (A)	T-19
15 PC_2 (B)	T-49
16 PC_3 (C)	T-34
17 PWRGND	Chassis Ground
18 RESERVED	
19 RESERVED	
20 TRGND	T-7
21 PC_4 (D)	T-64
22 PC_5 (E)	T-5
23 PC_6 (F)	T-4
24 PC_7 (LPC)	T-63
25 PC_8 (CPC)	T-79
26 RESERVED	

Ford Factory Shop Manual purchase options www.motorcraftservice.com



M-6017-73A 7.3L Engine Control Pack Installation Instructions

NO PART OF THIS DOCUMENT MAY BE REPRODUCED WITHOUT PRIOR AGREEMENT AND WRITTEN PERMISSION OF FORD PERFORMANCE PARTS © Ford Motor Company 2020

12.0 CAN Message Definition:

Parameter	PCM Units	Rate (ms)	Rate (Hz)	PCM->CAN Conversion	Range	Resolution	Num Bits	Offset	Notes
ENGINE_SPEED	RPM	10	100	None	0-16383	1	14	0	
ENGINE_SPEED_HZ	Hz	10	100	$\text{rpm}/60 \cdot 100$	0-163.83	0.01	14	0	0-9829 RPM
AF0	A/F	10	100	$((\text{lambda} \cdot \text{stoic_af}) - 7.0) \cdot 100$	7-27.47	0.01	11	7	Lambda converted to A/F based on Stoic A/F value
AF1	A/F	10	100	$((\text{lambda} \cdot \text{stoic_af}) - 7.0) \cdot 100$	7-27.47	0.01	11	7	Lambda converted to A/F based on Stoic A/F value
Fuel_Pressure	Kpa	10	100	$\text{psi} \cdot 6.89476$	0-511	1	9	0	Rail on PFI/Lift pump on DPFI
DI_Pressure	Kpa	10	100	$\text{psi} \cdot 6.89476$	0-32768	1	15	0	Only on DI/DPFI engines
BOOST	Kpa	10	100	$\text{psi} \cdot 6.89476$	0-511	1	9	0	Only On boosted engines, positive pressure only
VSPD	MPH	20	50	$\text{mph} \cdot 1.60934$	0-409.5	0.1	12	0	
MAN_VAC	InHg	20	50	$((\text{InHg} \cdot 3.38639) + 105) \cdot 10$	-105-409.5	0.1	12	-105	Gauge pressure
ECT	degF	100	10	$(\text{degF} - 32) \cdot 5/9$	-40-213	1	8	-40	214=degraded, 215=Faulted
EOT	degF	100	10	$(\text{degF} - 32) \cdot 5/9$	-40-213	1	8	-40	214=degraded, 215=Faulted
EOP	Kpa	100	10		0-1023	1	10	0	
VBAT	volts	100	10	$\text{vbat} \cdot 100$	0-20.47	0.01	11	0	
Codes_Count	-	100	10		0-255	1	8	0	
TOT	degF	100	10	$(\text{degF} - 32) \cdot 5/9$	-40-213	1	8	-40	214=degraded, 215=Faulted
Gear	-	100	10		0-15	1	4	0	
Shifter_Position	-	100	10		0-15	1	4	0	

Message ID	Transmitter	Rate (Hz)	Rate (ms)	Bit Number																																																																																							
				Byte 0								Byte 1								Byte 2								Byte 3								Byte 4								Byte 5								Byte 6								Byte 7																															
0x270	PCM	100	10	Res	0	1	2	3	4	5	6	7	8	9	10	11	12	13	14	15	16	17	18	19	20	21	22	23	24	25	26	27	28	29	30	31	32	33	34	35	36	37	38	39	40	41	42	43	44	45	46	47	48	49	50	51	52	53	54	55	56	57	58	59	60	61	62	63																							
0x274	PCM	50	20	Reserved								ENGINE_SPEED								ENGINE_SPEED_HZ								AF1								MAN_VAC								Res								DI_PRESSURE																																							
0x275	PCM	50	20	Reserved								BOOST								AF0								reserved								Fuel_Pressure								Reserved																																															
0x278	PCM	10	100	ECT								VSPD								EOT								TOT								EOP								Res								Shifter_Position								CODES_COUNT								VBAT								R								Gear							

Ford Factory Shop Manual purchase options www.motorcraftservice.com

NO PART OF THIS DOCUMENT MAY BE REPRODUCED WITHOUT PRIOR AGREEMENT AND WRITTEN PERMISSION OF FORD PERFORMANCE PARTS © Ford Motor Company 2020

13.0 Wiring Schematics (Control Pack, starter system, PCM pinout):

Control Pack Wiring:

Cowl Harness (control pack harness):

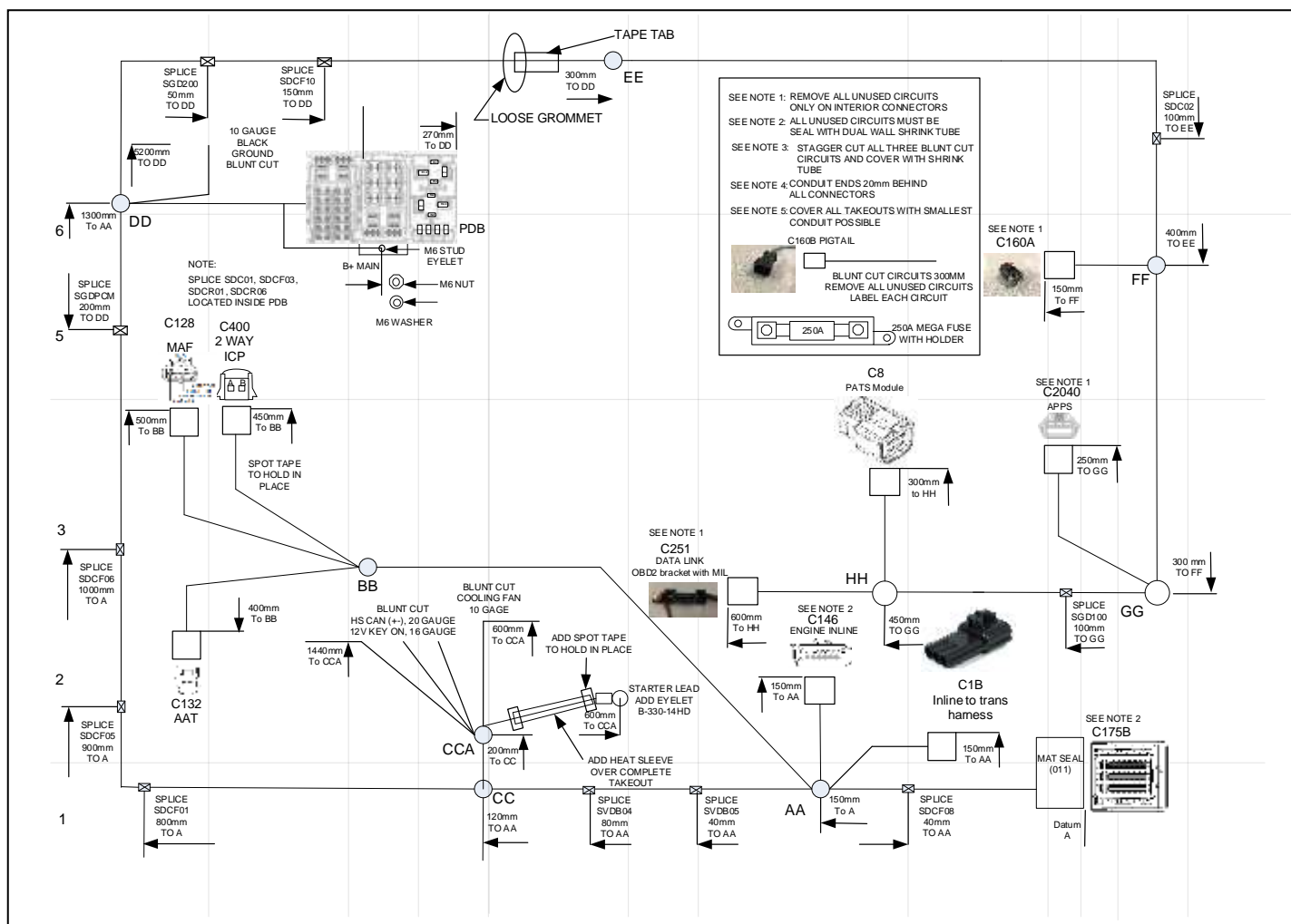

Ford Factory Shop Manual purchase options www.motorcraftservice.com

NO PART OF THIS DOCUMENT MAY BE REPRODUCED WITHOUT PRIOR AGREEMENT AND WRITTEN PERMISSION OF FORD PERFORMANCE PARTS © Ford Motor Company 2020

Automatic Transmission Harness

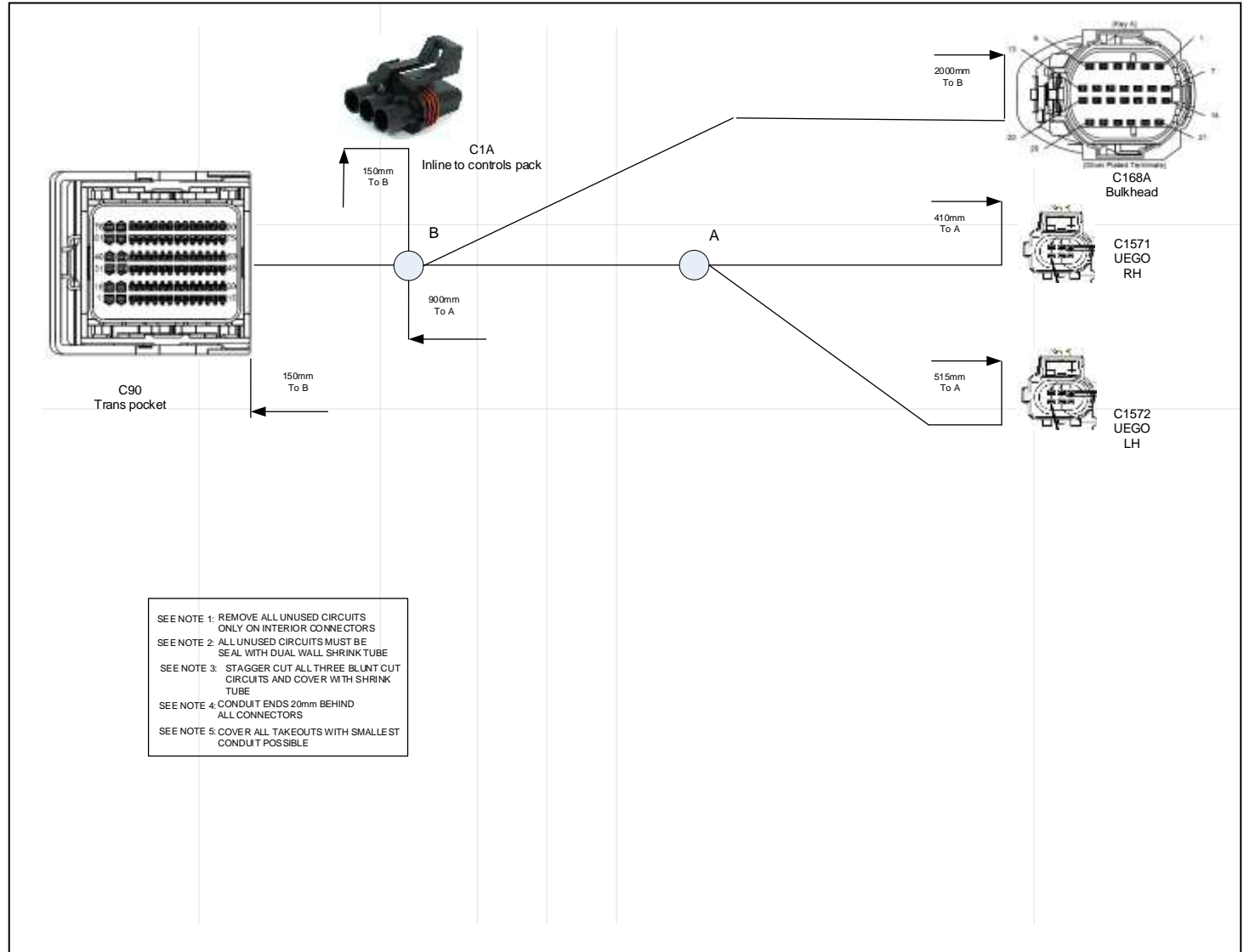

Ford Factory Shop Manual purchase options www.motorcraftservice.com



NO PART OF THIS DOCUMENT MAY BE REPRODUCED WITHOUT PRIOR AGREEMENT AND WRITTEN PERMISSION OF FORD PERFORMANCE PARTS © Ford Motor Company 2020

Engine Starter system schematic:

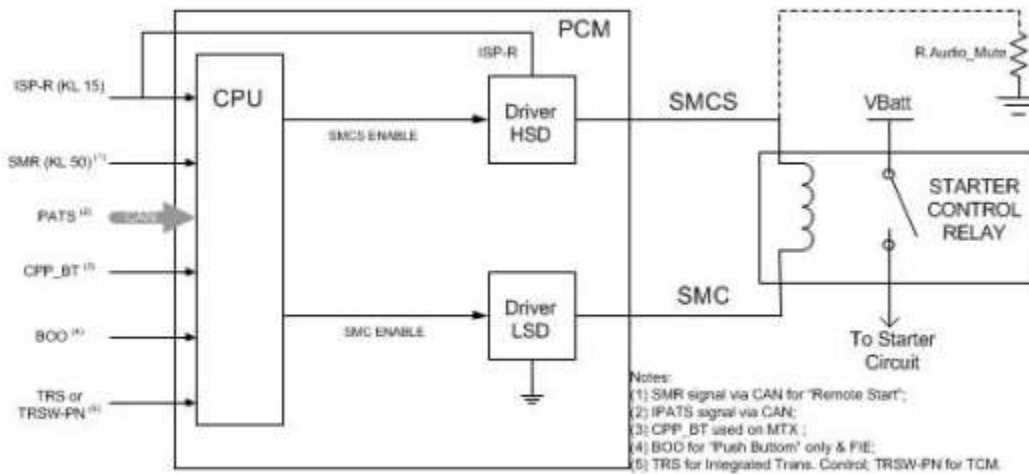

Ford Factory Shop Manual purchase options www.motorcraftservice.com



M-6017-73A 7.3L Engine Control Pack Installation Instructions

NO PART OF THIS DOCUMENT MAY BE REPRODUCED WITHOUT PRIOR AGREEMENT AND WRITTEN PERMISSION OF FORD PERFORMANCE PARTS © Ford Motor Company 2020

PCM Pinout:

Transmission Pocket						Engine Pocket						Vehicle Pocket					
Pin	Function	Index	Color	Other	IC	Pin	Function	Index	Color	Other	IC	Pin	Function	Index	Color	Other	IC
T1	TRSPN	2	8.01		03	E1						V1	VPWRH		1.00		3*
T2	TRSPN	3	8.01		03	E2						V2	VPWRH		1.00		3*
T3	PC (1-3)	31	1.06		03	E3						V3	SPR		2.00		03
T4	PC (1-3)	31	1.06		03	E4	SOI 200	11	1.18		04	V4	PCSV		2.00		03
T5	PC (1-3)	31	1.06		03	E5	SGRTN	ANA	1.03		03	V5					
T6						E6						V6	PCM WAKE		6.00		1*
T7	TRVND		1.03		03	E7						V7	SOO		1.15		1*
T8						E8	SH1	2	3.03		1*	V8					
T9						E9	RSL	11	3.02		1*	V9					
T10	ED-220XW	22	2.06		1*	E10						V10					
T11						E11						V11					
T12						E12	TPS	30.04			1*	V12	GAN (+) 1	HS	2.01		01
T13						E13						V13	SPR B		2.00		03
T14	UCS2SA	31	1.03		03	E14						V14	PRSP		1.00		03
T15	UCS2SA	31	1.03		03	E15						V15	SGFRG		1.12		03
T16	CHD	HM0522	1.09		03	E16						V16	VPWRH		1.00		3*
T17						E17	RA1 (-) 101	2H	1.11		04	V17					
T18						E18	RA1 (-) 101	2H	1.11		04	V18	TRC N		6.03		03
T19						E19						V19	AACD		1.07		04
T20						E20						V20	PTC Disengage		6.00		1*
T21						E21	COOP (A-1)	1A	12.01		03	V21	PTC Request		6.00		1*
T22						E22						V22	SMR		2.03		1*
T23						E23						V23	SPR		6.00		1*
T24						E24						V24	AT	11	19.01		1*
T25						E25						V25	PTC PCM		6.00		1*
T26	WCP 6W		6.00		1*	E26						V26	SGRTN	ANA	1.03		03
T27	WCP 6W		6.00		1*	E27						V27	GAN (+) 1	HS	2.01		01
T28	WCP 6W		6.00		1*	E28						V28	SGRTN	ANA	1.03		03
T29	UCS2SP	31	1.03		03	E29	RSL	11+	3.02		1*	V29	PRSP		2.00		03
T30	UCS2SP	31	1.03		03	E30						V30	CTC		6.04		03
T31						E31						V31					
T32						E32						V32					
T33	PC (1-3)	31	1.06		03	E33						V33	GANNVT		6.01		03
T34	TRSP		6.00		1*	E34						V34					
T35	TRSP		6.00		1*	E35	RA1 (-) 101	2H	1.11		04	V35	GANEL		2	1.13	1*
T36	TRSP		6.00		1*	E36	RA1 (-) 101	2H	1.11		04	V36	WDR		1.10		1*
T37	TRSP		6.00		1*	E37	RA1 (-) 101	2H	1.11		04	V37	WDR		1.10		1*
T38	TRSP		6.00		1*	E38						V38					
T39	TRSP		6.00		1*	E39	COOP (A-1)	1A	12.01		03	V39					
T40	TRSP		6.00		1*	E40						V40	SMR2		3.00		03
T41	TRSP		6.00		1*	E41						V41	PTC Relay		6.00		03
T42	TRSP		6.00		1*	E42						V42	WDR		1.00		03
T43	TRSP		6.00		1*	E43	SGRTN	ANA	1.03		03	V43	WDR		1.00		03
T44	TRSP		6.00		1*	E44						V44	EVAPSV		6.00		03
T45	TRSP		6.00		1*	E45						V45					
T46	TRSP		6.00		1*	E46						V46	GANEL		1	1.13	1*
T47	TRSP		6.00		1*	E47	RSL	21+	3.02		1*	V47	PTC PCM		2	2.11	1*
T48	TRSP		6.00		1*	E48	RSL	12+	3.02		1*	V48	RA1 2ND		3	3.00	1*
T49	TRSP		6.00		1*	E49						V49					
T50	TRSP		6.00		1*	E50						V50					
T51	TRSP		6.00		1*	E51						V51	APR1 20		1	2.01	1*
T52	TRSP		6.00		1*	E52						V52	PTC		1	1.12	03
T53	TRSP		6.00		1*	E53						V53	MAPRIN		1	1.02	03
T54	TRSP		6.00		1*	E54						V54	TRD P		1	6.03	03
T55	TRSP		6.00		1*	E55						V55	CHRG		1	1.07	03
T56	TRSP		6.00		1*	E56						V56	EVAPSV		1	1.02	03
T57	TRSP		6.00		1*	E57	COOP (A-1)	1A	12.01		03	V57	EVAPSV		1	6.00	03
T58	TRSP		6.00		1*	E58	COOP (A-1)	1A	12.01		03	V58	GANEL		1	1.13	1*
T59	TRSP		6.00		1*	E59						V59	WDR		1	6.03	03
T60	TRSP		6.00		1*	E60						V60	SR1 2ND		1	3.02	1*
T61	TRSP		6.00		1*	E61						V61					
T62	TRSP		6.00		1*	E62	COOP		6.04		1*	V62	APR1 20		2	2.01	1*
T63	TRSP		6.00		1*	E63						V63	ACPT		1	2.00	1*
T64	TRSP		6.00		1*	E64						V64	ETP TRF		1	1.04	03
T65	TRSP		6.00		1*	E65	RSL	21-	3.02		1*	V65	WDR		1	2.03	03
T66	TRSP		6.00		1*	E66						V66	WDR		1	1.04	03
T67	TRSP		6.00		1*	E67	RSL	12-	3.02		1*	V67	SGRTN	HS4	1	1.03	03
T68	TRSP		6.00		1*	E68						V68	SGFRG		1	1.12	03
T69	TRSP		6.00		1*	E69						V69	WDR		1	6.01	03
T70	TRSP		6.00		1*	E70	WMP 11	11	6.11		1*	V70	EVAPSV		1	1.00	03
T71	TRSP		6.00		1*	E71						V71	EVAPSV		1	1.00	03
T72	TRSP		6.00		1*	E72	WCP 14		1.07		1*	V72	EVAPSV		1	1.00	03
T73	TRSP		6.00		1*	E73	RSL	22-	3.02		1*	V73	WDR		1	3.07	03
T74	TRSP		6.00		1*	E74						V74	WDR		1	2.06	03
T75	TRSP		6.00		1*	E75	RA1 (-) 101	2H	1.11		04	V75	WDR		1	1.00	03
T76	TRSP		6.00		1*	E76	COOP (A-1)	1A	12.01		03	V76	WDR		1	6.00	03
T77	TRSP		6.00		1*	E77	COOP (A-1)	1A	12.01		03	V77	WDR		1	6.00	03
T78	TRSP		6.00		1*	E78	TACM (-)	-	3.05		03	V78	WDR		1	6.00	03
T79	TRSP		6.00		1*	E79						V79	WDR		1	6.00	03
T80	TRSP		6.00		1*	E80						V80	WDR		1	6.00	03
T81	TRSP		6.00		1*	E81						V81	WDR		1	6.00	03
T82	TRSP		6.00		1*	E82						V82	WDR		1	6.00	03
T83	TRSP		6.00		1*	E83						V83	WDR		1	6.00	03
T84	TRSP		6.00		1*	E84						V84	WDR		1	6.00	03
T85	TRSP		6.00		1*	E85						V85	WDR		1	6.00	03
T86	TRSP		6.00		1*	E86						V86	WDR		1	6.00	03
T87	TRSP		6.00		1*	E87						V87	WDR		1	6.00	03
T88	TRSP		6.00		1*	E88						V88	WDR		1	6.00	03
T89	TRSP		6.00		1*	E89						V89	WDR		1	6.00	03
T90	TRSP		6.00		1*	E90						V90	WDR		1	6.00	03
T91	TRSP		6.00		1*	E91						V91	WDR		1	6.00	03
T92	TRSP		6.00		1*	E92						V92	WDR		1	6.00	03
T93	TRSP		6.00		1*	E93						V93	WDR		1	6.00	03
T94	TRSP		6.00		1*	E94						V94	WDR		1	6.00	03
T95	TRSP		6.00		1*	E95						V95	WDR		1	6.00	03
T96	TRSP		6.00		1*	E96						V96	WDR		1	6.00	03
T97	TRSP		6.00		1*	E97						V97	WDR		1	6.00	03
T98	TRSP		6.00		1*	E98						V98	WDR		1	6.00	03
T99	TRSP		6.00		1*	E99						V99	WDR		1	6.00	03
T100	TRSP		6.00		1*	E100						V100	WDR		1	6.00	03
T101						E101						V101					
T102						E102						V102					
T103						E103						V103					
T104						E104						V104					
T105						E105	COOP (A-1)	1A	12.01		03	V105					
T106						E106	TACM (-)	-	3.05		03	V106					
T107						E107						V107					
T108						E108						V108					
T109						E109						V109					
T110						E110	RA1 (-) 101	2H	1.11		04	V110					
T11																	