



M-F150-W1,W2,W3,W4,W5
2025-26MY F-150 Super Crew XLT Black Pack & Black Pack Plus
Regional Package

NO PART OF THIS DOCUMENT MAY BE REPRODUCED WITHOUT PRIOR AGREEMENT AND WRITTEN PERMISSION OF
FORD PERFORMANCE PARTS © Ford Motor Company 2020

PRIOR TO INSTALLATION READ THESE INSTRUCTIONS COMPLETELY
For questions, Call the FORD PERFORMANCE Techline 1-800-367-3788

Please visit <https://www.performanceparts.ford.com> for warranty information



Great Lakes Edition Shown With Optional 22" Wheels

Ford Factory Shop Manual purchase options www.motorcraftservice.com



M-F150-W1,W2,W3,W4,W5
2025-26MY F-150 Super Crew XLT Black Pack & Black Pack Plus
Regional Package

NO PART OF THIS DOCUMENT MAY BE REPRODUCED WITHOUT PRIOR AGREEMENT AND WRITTEN PERMISSION OF
FORD PERFORMANCE PARTS © Ford Motor Company 2020

Package Contents:

<u>Description</u>	<u>Quantity</u>
Rocker Panel Aero Shield Delete Kit	1
F-150 Regional Graphics Kit	1
F-150 Regional Package Wheel Kit	1
Black Lug Nut Kit	1

Installation Section:

1. [Altered Vehicle Label](#)
2. [Rocker Panel Aero Shield Delete Kit](#)
3. [F-150 Regional Graphics Kit](#)
4. [F-150 Regional Wheels, TPMS Sensors & Lug Nuts](#)
5. [Service Procedures](#)

Ford Factory Shop Manual purchase options www.motorcraftservice.com

NO PART OF THIS DOCUMENT MAY BE REPRODUCED WITHOUT PRIOR AGREEMENT AND WRITTEN PERMISSION OF
FORD PERFORMANCE PARTS © Ford Motor Company 2020

1. Altered Vehicle Label

IMPORTANT: AN ALTERED VEHICLE LABEL IS ONLY REQUIRED IF THE VEHICLE'S WHEEL OR TIRE SIZES DIFFER FROM ITS ORIGINAL FACTORY SPECIFICATIONS.

NOTE: THE ROOM TEMPERATURE AND SURFACE TEMPERATURE MUST BE NO LOWER THAN 68 DEGREES FAHRENHEIT (20° C) OR HIGHER THAN 90 DEGREES FAHRENHEIT (32° C) TO ENSURE PROPER INSTALLATION.

1. On the driver side, clean the area above the vehicle certification label with alcohol wipe and let dry.



2. Apply the altered vehicle label in the cleaned area.
3. With a permanent marker, fill out the altered vehicle label with the name of installer, date of installation, equipped tire size, and tire pressure.

2. Rocker Panel Aero Shield Delete Kit

[INSTRUCTION SHEET](#)

Ford Factory Shop Manual purchase options www.motorcraftservice.com



FORD PERFORMANCE

M-F150-W1,W2,W3,W4,W5 2025-26MY F-150 Super Crew XLT Black Pack & Black Pack Plus Regional Package

NO PART OF THIS DOCUMENT MAY BE REPRODUCED WITHOUT PRIOR AGREEMENT AND WRITTEN PERMISSION OF FORD PERFORMANCE PARTS © Ford Motor Company 2020

3. F-150 Regional Graphics Kit

A

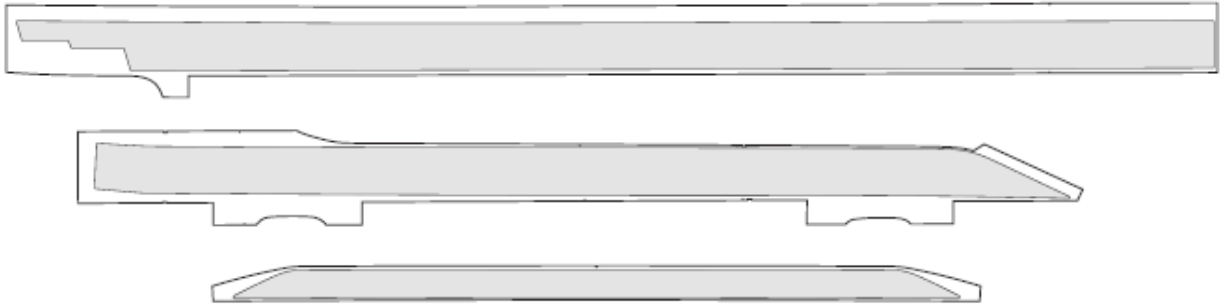

B

TOOLS REQUIRED

SOAP AND WATER SOLUTION



SQUEEGEE

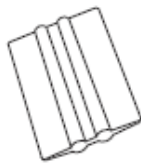

KNIFE



ALCOHOL WIPES



SOFT CLOTH

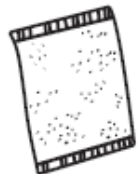

Ford Factory Shop Manual purchase options www.motorcraftservice.com



FORD PERFORMANCE

M-F150-W1,W2,W3,W4,W5

2025-26MY F-150 Super Crew XLT Black Pack & Black Pack Plus
Regional Package

NO PART OF THIS DOCUMENT MAY BE REPRODUCED WITHOUT PRIOR AGREEMENT AND WRITTEN PERMISSION OF
FORD PERFORMANCE PARTS © Ford Motor Company 2020

1

NOTE: THE ROOM TEMPERATURE AND SURFACE TEMPERATURE MUST BE NO LOWER THAN 68 DEGREES FAHRENHEIT (20° C) OR HIGHER THAN 90 DEGREES FAHRENHEIT (32° C) TO ENSURE PROPER INSTALLATION.



2

NOTE: CLEAN SURFACE WITH NAPHTHA BASE CLEANER TO REMOVE DIRT AND GREASE. REMOVE RESIDUE FROM AREA AND ALLOW AREA TO DRY THOROUGHLY.

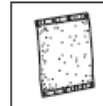
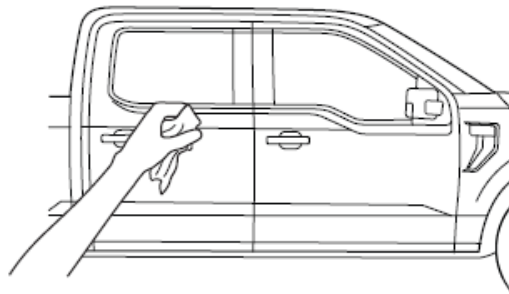

3

CREW CAB

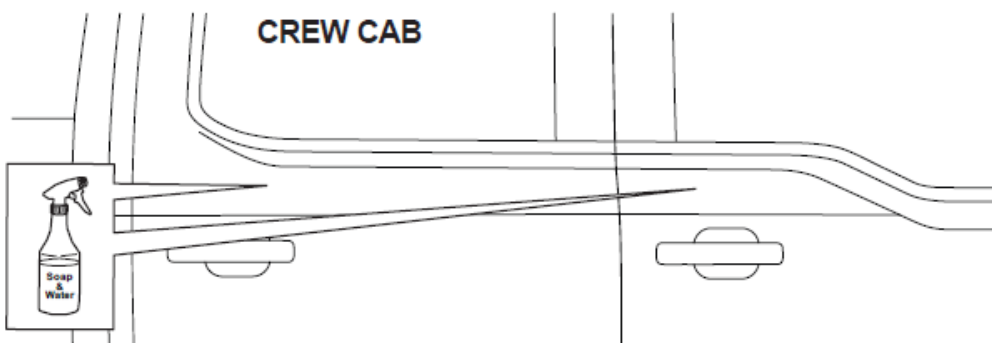

4

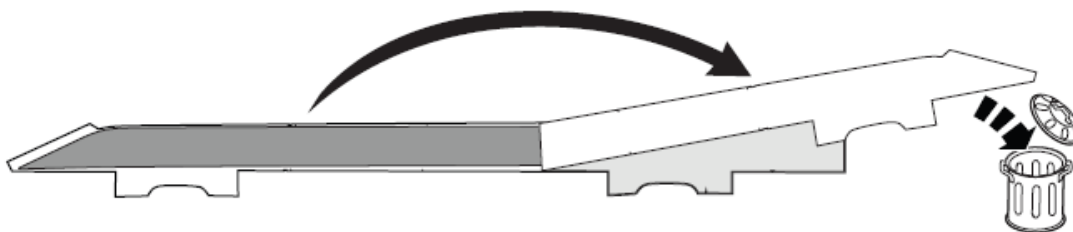

Ford Factory Shop Manual purchase options www.motorcraftservice.com



FORD PERFORMANCE

M-F150-W1,W2,W3,W4,W5

2025-26MY F-150 Super Crew XLT Black Pack & Black Pack Plus
Regional Package

NO PART OF THIS DOCUMENT MAY BE REPRODUCED WITHOUT PRIOR AGREEMENT AND WRITTEN PERMISSION OF
FORD PERFORMANCE PARTS © Ford Motor Company 2020

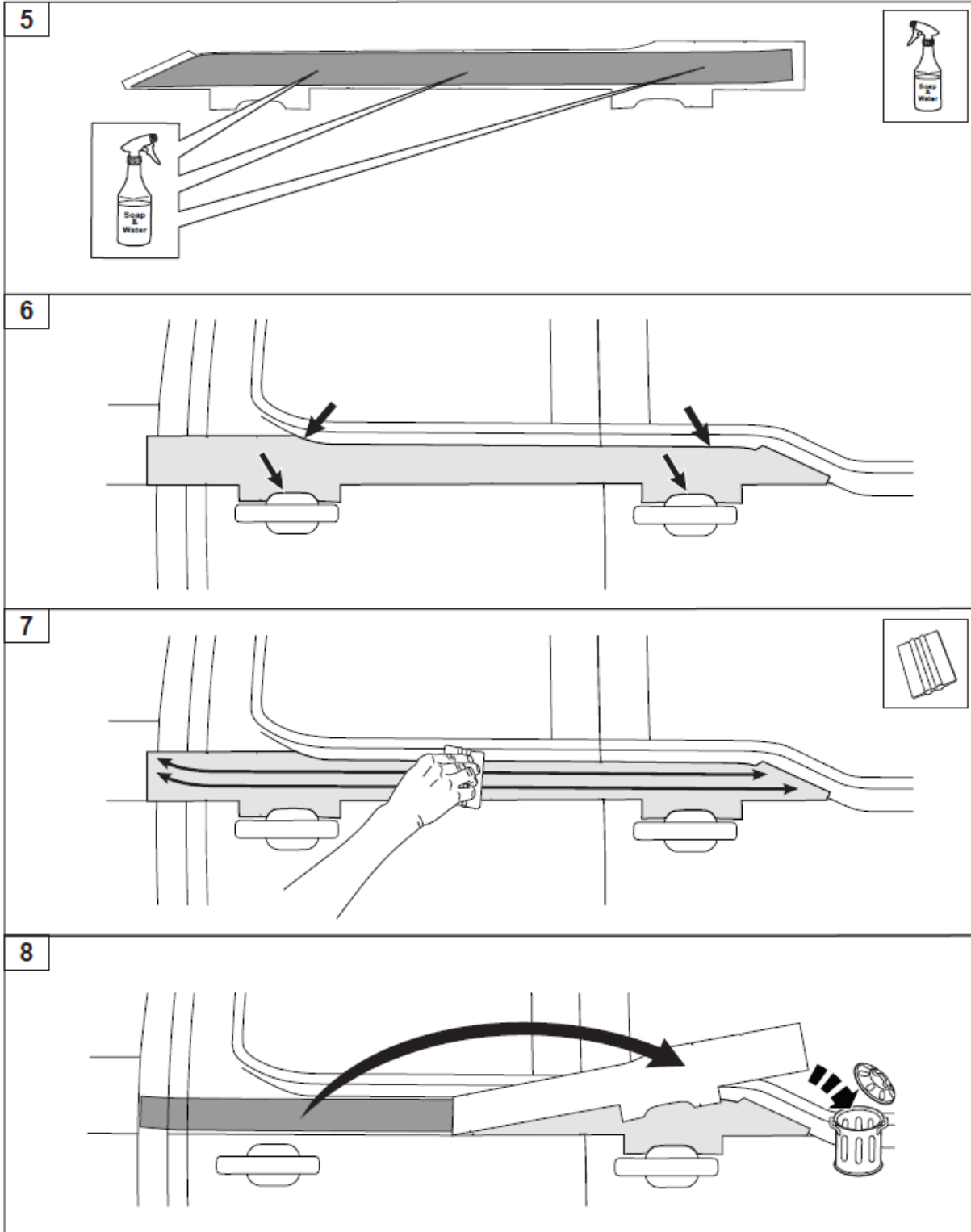

Ford Factory Shop Manual purchase options www.motorcraftservice.com



FORD PERFORMANCE

M-F150-W1,W2,W3,W4,W5

2025-26MY F-150 Super Crew XLT Black Pack & Black Pack Plus
Regional Package

NO PART OF THIS DOCUMENT MAY BE REPRODUCED WITHOUT PRIOR AGREEMENT AND WRITTEN PERMISSION OF
FORD PERFORMANCE PARTS © Ford Motor Company 2020

9

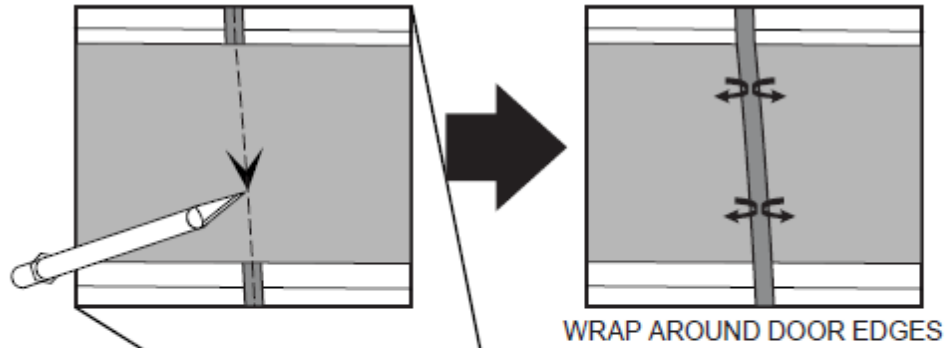

Ford Factory Shop Manual purchase options www.motorcraftservice.com



FORD PERFORMANCE

M-F150-W1,W2,W3,W4,W5

2025-26MY F-150 Super Crew XLT Black Pack & Black Pack Plus
Regional Package

NO PART OF THIS DOCUMENT MAY BE REPRODUCED WITHOUT PRIOR AGREEMENT AND WRITTEN PERMISSION OF
FORD PERFORMANCE PARTS © Ford Motor Company 2020

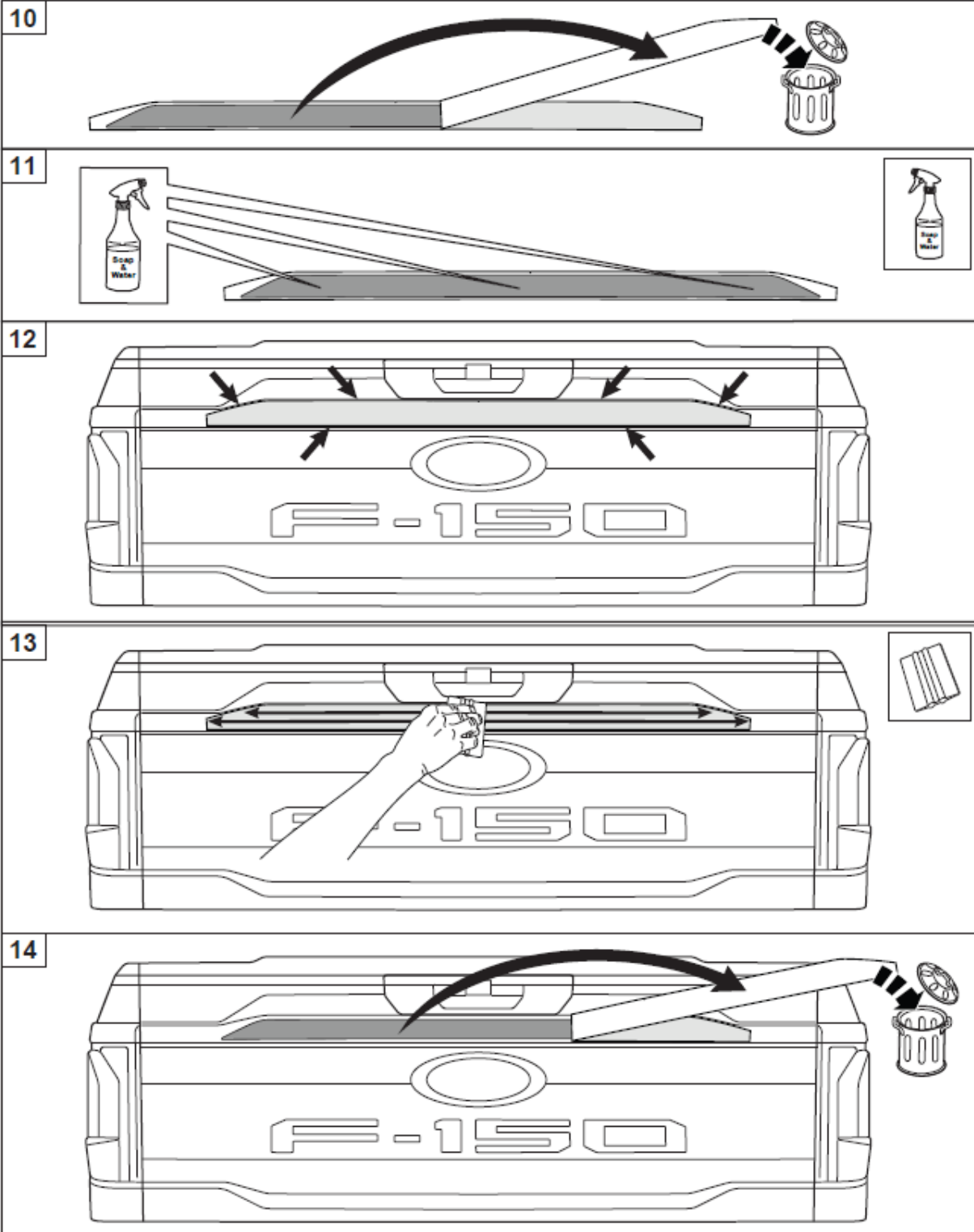

Ford Factory Shop Manual purchase options www.motorcraftservice.com



M-F150-W1,W2,W3,W4,W5
2025-26MY F-150 Super Crew XLT Black Pack & Black Pack Plus
Regional Package

NO PART OF THIS DOCUMENT MAY BE REPRODUCED WITHOUT PRIOR AGREEMENT AND WRITTEN PERMISSION OF
FORD PERFORMANCE PARTS © Ford Motor Company 2020

4. F-150 Regional Wheels, TPMS Sensors & Lug Nuts

Special Tool(s) / General Equipment

Wooden Block

NOTICE: Ford Recommends The Following For Vehicles With Carbon Fiber And Alloy Wheels:

- **Tire Changer:**
 - Ford requires center clamp style tire changers such as Hunter® Auto 34, Revolution, TC3900 or equivalent. Anything else, especially table top style machines, are highly likely to damage the wheel which is not warrantable. Do not use table top design machines that grab onto the inside of the wheel and that ride on the front wheel flange to remove the tire. Wheel damage will occur.
- **Tire Balancer:**
 - Ford requires the use of wheel balancers that do not contact the wheel face such as, Hunter® Road Force Touch GSP9700. Do not use machines that contact the wheel face. Wheel damage will occur.

NOTICE: Failure to follow the instructions below may result in damage to the TPMS .

NOTICE: The TPMS sensor is mounted to the valve stem. Removal of the valve stem requires dismounting the tire from the wheel and removal of the TPMS sensor.

NOTE: Use only the Digital Tire Pressure Gauge any time tire pressures are measured to be sure that accurate values are obtained.

Ford Factory Shop Manual purchase options www.motorcraftservice.com



NO PART OF THIS DOCUMENT MAY BE REPRODUCED WITHOUT PRIOR AGREEMENT AND WRITTEN PERMISSION OF
FORD PERFORMANCE PARTS © Ford Motor Company 2020

Removal

1. With the vehicle in NEUTRAL, position it on a hoist.

Jacking Points – Front

 **WARNING:** When jacking or lifting the vehicle, block all wheels remaining on the ground. Set the parking brake if the rear wheels will remain on the ground. These actions help prevent unintended vehicle movement. Failure to follow these instructions may result in serious personal injury.

 **WARNING:** Never get underneath a vehicle that is supported only by a jack. The jack could unintentionally lower. Always support vehicle with floor stands. Failure to follow these instructions may result in serious personal injury.

 **WARNING:** Only raise the vehicle when positioned on a hard, level surface. Attempting to raise the vehicle on an uneven or soft surface may result in vehicle slipping or falling from the jack or jackstand. Failure to follow this instruction may result in serious personal injury.

 **WARNING:** Turn off (disable) the power running boards (if equipped) before jacking, lifting or placing any object under the vehicle. Never place your hand between the power running board and the vehicle. Extended power running boards will retract when doors are closed. Failure to follow these instructions may result in serious personal injury.

 **WARNING:** Front jacking point could be identified by an arrow marking on the vehicle frame. Raising a vehicle in any other location may result in vehicle shifting or falling. Failure to follow this instruction may result in serious personal injury.

Ford Factory Shop Manual purchase options www.motorcraftservice.com



FORD PERFORMANCE

M-F150-W1,W2,W3,W4,W5

2025-26MY F-150 Super Crew XLT Black Pack & Black Pack Plus
Regional Package

NO PART OF THIS DOCUMENT MAY BE REPRODUCED WITHOUT PRIOR AGREEMENT AND WRITTEN PERMISSION OF
FORD PERFORMANCE PARTS © Ford Motor Company 2020

NOTE: SuperCrew Cab 4WD shown, others similar.

NOTE: LH side shown, RH side similar.

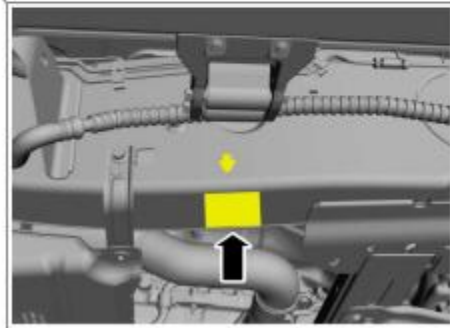
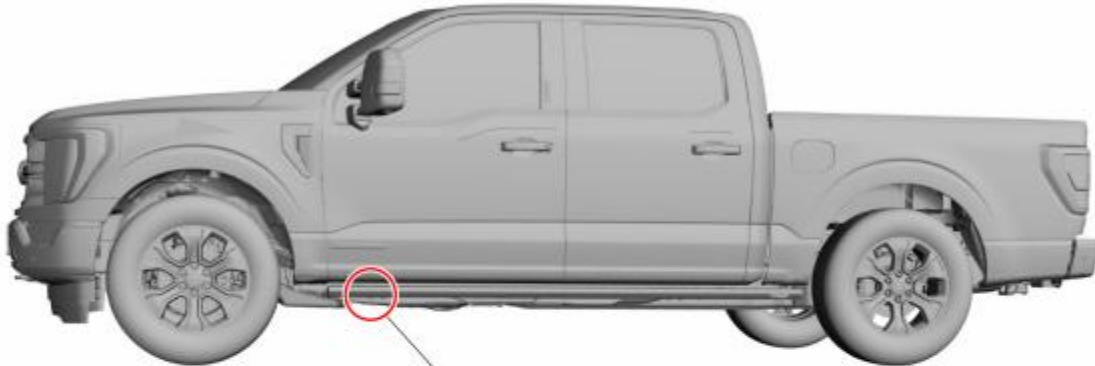

E329513

Only the specified jacking points may be used for jacking and supporting the vehicle.

Ford Factory Shop Manual purchase options www.motorcraftservice.com

NO PART OF THIS DOCUMENT MAY BE REPRODUCED WITHOUT PRIOR AGREEMENT AND WRITTEN PERMISSION OF
FORD PERFORMANCE PARTS © Ford Motor Company 2020

Jacking Points – Rear

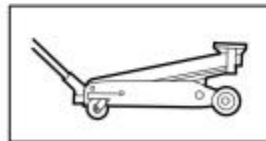

E190340

NOTICE: Do not use the differential housing as a lift point. Leaks or damage to the rear axle cover and adjoining differential housing surface may occur if a floor jack or any lifting device is allowed to contact the cover at any point where the cover joins the housing.

NOTE: *Rear bumper removed for clarity.*

Only the specified jacking points may be used for jacking and supporting the vehicle.

The rear jacking points are located on the rear axle.

Ford Factory Shop Manual purchase options www.motorcraftservice.com

NO PART OF THIS DOCUMENT MAY BE REPRODUCED WITHOUT PRIOR AGREEMENT AND WRITTEN PERMISSION OF
FORD PERFORMANCE PARTS © Ford Motor Company 2020

Lifting Points – Front and Rear

HEV

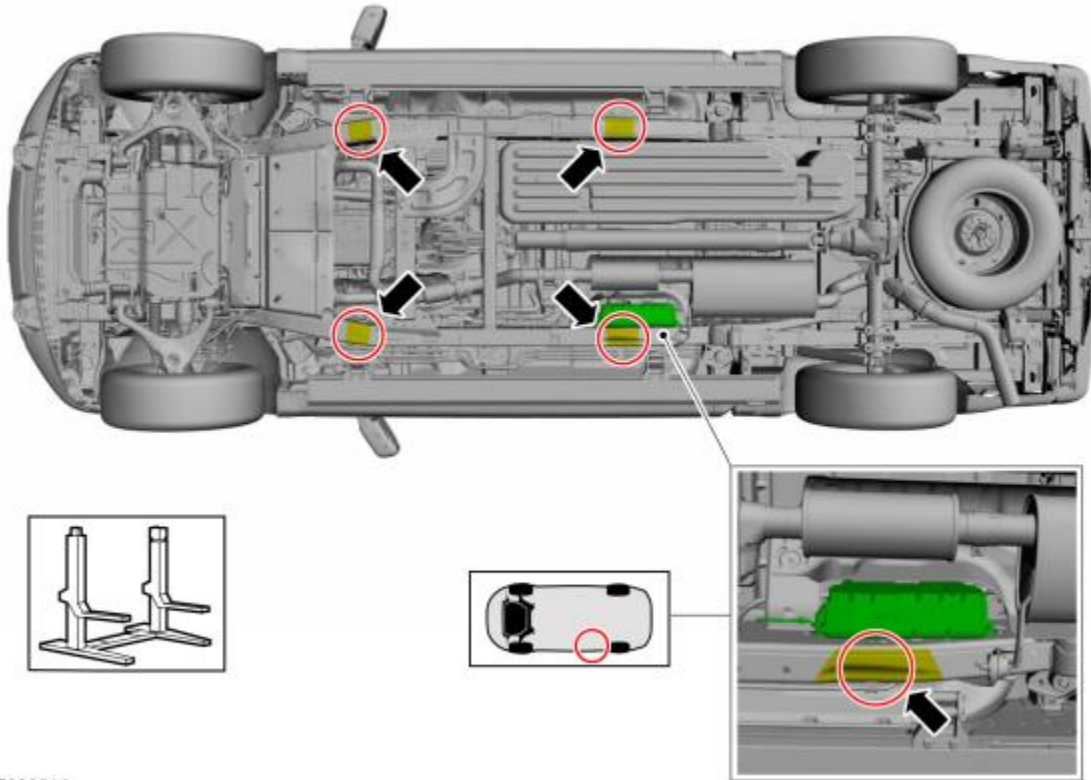

E329514

NOTICE: Make sure that no load is placed on the Direct Current/Alternating Current (DC/AC) Inverter Module.



FORD PERFORMANCE

M-F150-W1,W2,W3,W4,W5

2025-26MY F-150 Super Crew XLT Black Pack & Black Pack Plus
Regional Package

NO PART OF THIS DOCUMENT MAY BE REPRODUCED WITHOUT PRIOR AGREEMENT AND WRITTEN PERMISSION OF
FORD PERFORMANCE PARTS © Ford Motor Company 2020

All vehicles

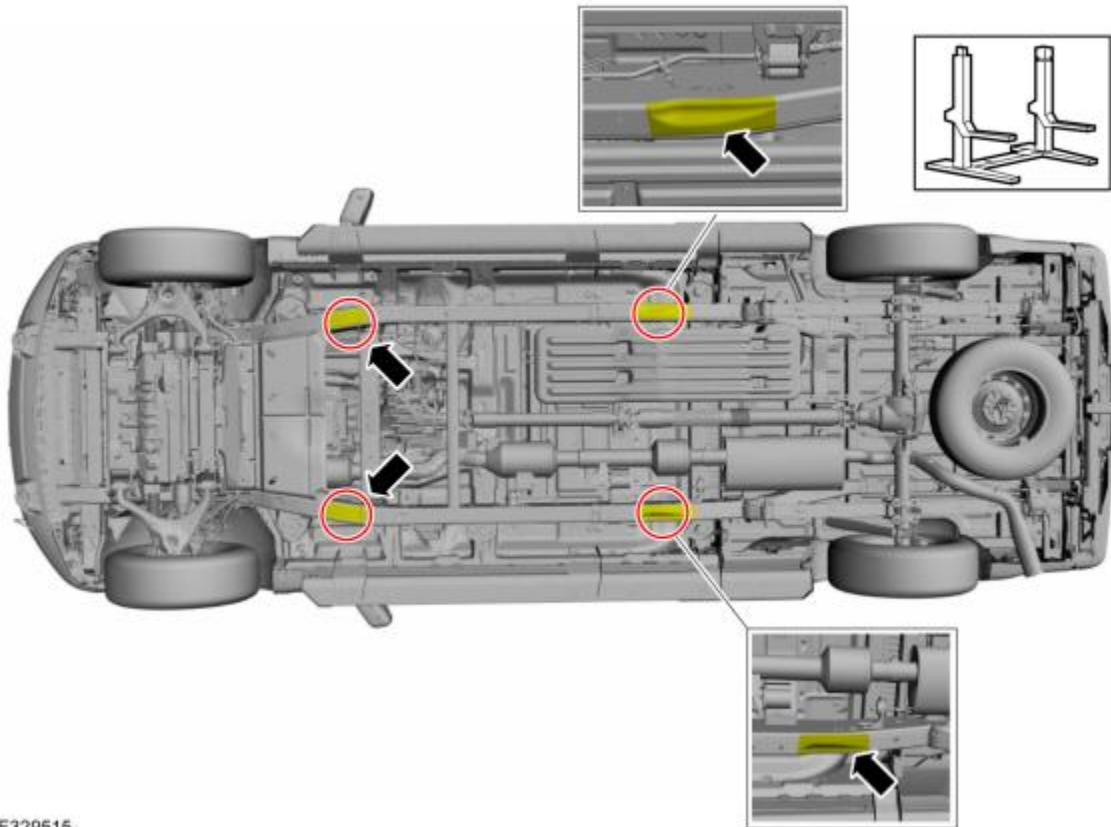

E329515

NOTE: 4WD shown, RWD similar.

⚠ WARNING: Position the hoist lift arms as shown in the illustration. Incorrect positioning could result in vehicle slipping or falling from the hoist. Failure to follow this instruction may result in serious personal injury.

NOTICE: The jack provided with the vehicle is intended to be used in an emergency for changing a deflated tire. To avoid damage to the vehicle, never use the jack to hoist the vehicle for any other purpose.

NOTICE: Do not attempt to use jack pressure on either the front bumper or the rear bumper on any vehicle. Damage to bumper covers will occur.

NOTICE: Place blocks underneath the lifting points if a two-column hoist is used.

NOTICE: Damage to the suspension, exhaust or steering linkage components may occur if care is not exercised when positioning the hoist adapters prior to lifting the vehicle.

Ford Factory Shop Manual purchase options www.motorcraftservice.com

NO PART OF THIS DOCUMENT MAY BE REPRODUCED WITHOUT PRIOR AGREEMENT AND WRITTEN PERMISSION OF
FORD PERFORMANCE PARTS © Ford Motor Company 2020

NOTICE: To prevent possible damage to the underbody, do not drive the vehicle onto the drive-on lift without first checking for possible interference.

NOTICE: When raising a vehicle on a two-column hoist, use care when positioning the vehicle so that the hoisting forks do not interfere with suspension components, mounting brackets or stabilizer mounting brackets, if equipped. In addition, use care in hoist positioning to avoid possible damage to the axle or rear cover.

2. **NOTE:** *If equipped.*

Remove the center cap.

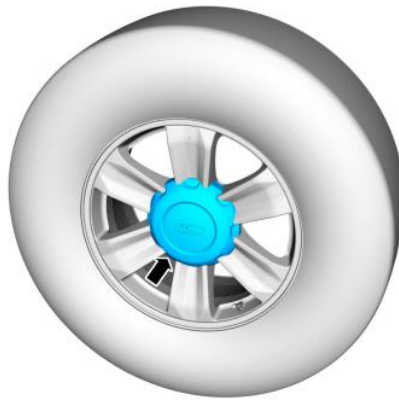

E190249

3. **NOTICE:** Do not use heat to loosen a seized wheel nut or damage to the wheel and wheel bearing can occur.

NOTICE: If equipped with full wheel cover with exposed wheel nuts, the wheel nuts must be removed prior to removing the wheel cover or damage to the wheel cover will occur.

NOTE: *Use metric hexagonal socket.*

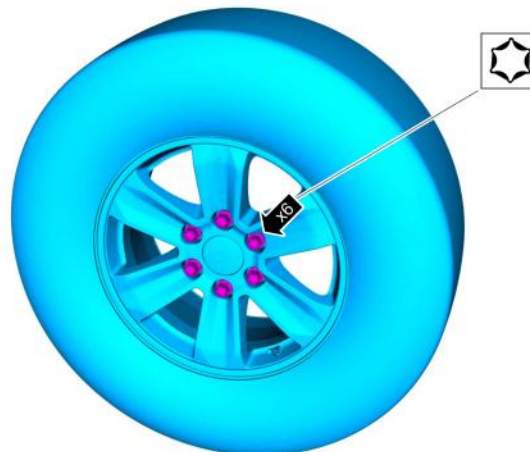

E190250

Ford Factory Shop Manual purchase options www.motorcraftservice.com

NO PART OF THIS DOCUMENT MAY BE REPRODUCED WITHOUT PRIOR AGREEMENT AND WRITTEN PERMISSION OF
FORD PERFORMANCE PARTS © Ford Motor Company 2020

4. **NOTICE:** The valve stem is connected to the TPMS sensor. Do not pull the valve stem from the wheel, or damage to the sensor will occur.

NOTE: If a new TPMS sensor is being installed, remove and discard the valve stem-to-sensor screw and the sensor.

Remove the valve stem core and fully deflate all air from the tire.

5. **NOTICE:** Do not allow the tire beads to move beyond the wheel mid-plane (middle of the wheel) when separating the beads from the wheels, damage to the TPMS sensor may occur.

NOTICE: Tire and valve stem position is critical to prevent damage to the TPMS sensor when using a paddle-type bead separator.

NOTE: Some machines may have a nylon roller bead separator at the 12 o'clock position instead of the paddle-type bead separator at the 3 o'clock position.

- For a paddle-type tire machine, position the valve stem at the 12 o'clock or 6 o'clock position and the paddle at the 3 o'clock position.
- For a roller-type tire machine, align the valve stem with the roller at any position.

NOTE: Paddle type shown, roller type similar.

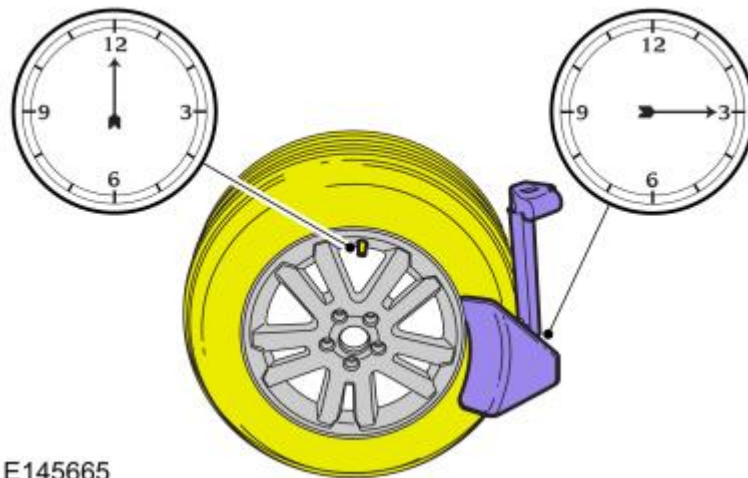



FORD PERFORMANCE

M-F150-W1,W2,W3,W4,W5

2025-26MY F-150 Super Crew XLT Black Pack & Black Pack Plus
Regional Package

NO PART OF THIS DOCUMENT MAY BE REPRODUCED WITHOUT PRIOR AGREEMENT AND WRITTEN PERMISSION OF
FORD PERFORMANCE PARTS © Ford Motor Company 2020

6. **NOTE:** *Index-mark the valve stem and wheel weight positions on the tire.*

Place the wheel and tire assembly on the turntable of the tire machine with the valve stem at the 11:30 position and the machine arm at the 12 o'clock position and dismount the outer bead from the wheel.

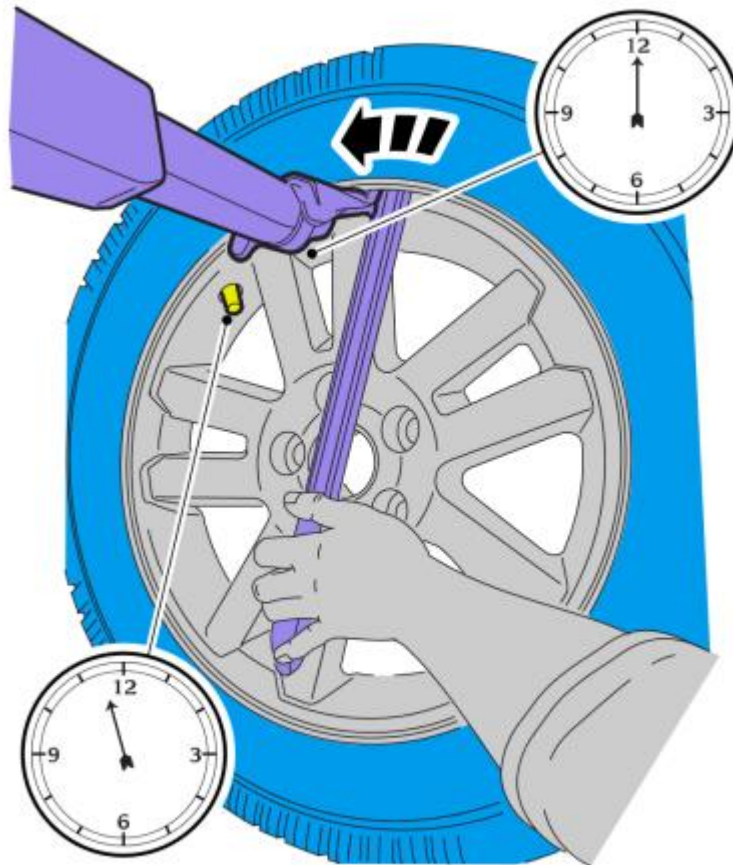

E145667

7. Reset the wheel and tire assembly on the turntable of the tire machine with the valve stem at the 11:30 position and the machine arm at the 12 o'clock position and dismount the inner bead from the wheel.

Ford Factory Shop Manual purchase options www.motorcraftservice.com

NO PART OF THIS DOCUMENT MAY BE REPRODUCED WITHOUT PRIOR AGREEMENT AND WRITTEN PERMISSION OF
FORD PERFORMANCE PARTS © Ford Motor Company 2020

8. **NOTE:** *A new valve stem must be installed whenever a new tire or wheel is installed.*

1. Remove and discard the TPMS sensor-to-valve stem screw.
2. Separate the TPMS sensor from the valve stem.

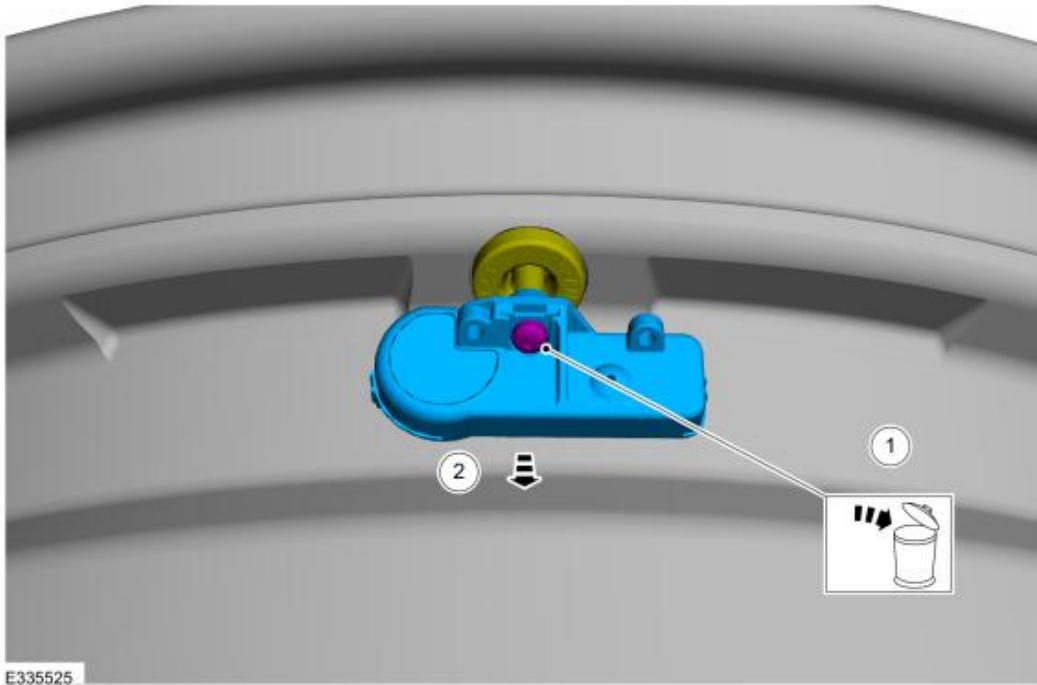

9. **NOTICE:** Use care not to damage the wheel surface when removing the valve stem.

Using a suitable valve stem remover/installer, remove and discard the valve stem.
Use the General Equipment: Wooden Block

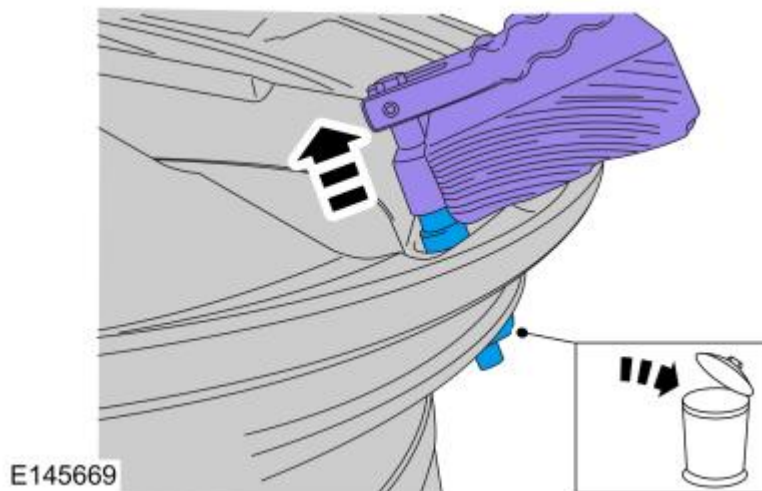

Ford Factory Shop Manual purchase options www.motorcraftservice.com

NO PART OF THIS DOCUMENT MAY BE REPRODUCED WITHOUT PRIOR AGREEMENT AND WRITTEN PERMISSION OF
FORD PERFORMANCE PARTS © Ford Motor Company 2020

NOTE: *When installing a new wheel, always install a new valve stem and sensor screw. Reuse the TPMS sensor from the previous wheel if possible. The TPMS will not have to be trained if the sensor is reused.*

NOTE: *If the TPMS sensor is being reused, inspect the TPMS sensor for damage and install a new sensor as necessary.*

10. NOTICE: To prevent TPMS sensor and valve stem damage, the valve stem must be installed onto the TPMS sensor and then installed into the wheel as an assembly.

Position the new valve stem onto the TPMS sensor and install the new screw.

Torque: 13 lb.in (1.5 Nm)

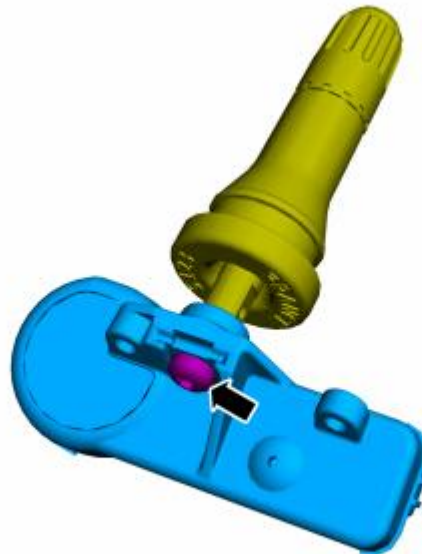

E335526

NO PART OF THIS DOCUMENT MAY BE REPRODUCED WITHOUT PRIOR AGREEMENT AND WRITTEN PERMISSION OF
FORD PERFORMANCE PARTS © Ford Motor Company 2020

Installation

NOTICE: Damage to the TPMS sensor may result if the tire mounting is not carried out as instructed.

1. **NOTICE:** It is important to pull the valve stem and TPMS sensor assembly through the wheel rim hole in a direction parallel to the valve stem hole axis. If the assembly is pulled through at an angle, damage to the valve stem and sensor assembly may occur.

NOTICE: Use care not to damage the wheel surface when installing the valve stem and TPMS sensor assembly.

NOTE: Lubricate the valve stem with soapy water and install the valve stem and TPMS sensor assembly into the wheel using a block of wood and a suitable valve stem installer.

Using a suitable valve stem installer, install the new valve stem and TPMS sensor assembly.

Use the General Equipment: Wooden Block

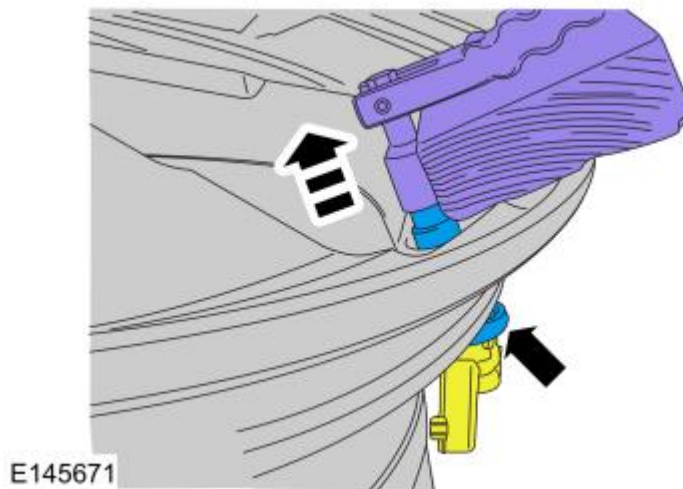

2. **NOTE:** Lubricate the tire beads using a suitable fast-drying, corrosion-inhibiting tire bead lubricant.

NOTE: Do not mount the tire at this time.

Position the wheel on the turntable of the tire machine, then lubricate and position the bottom bead of the tire on the wheel.

NO PART OF THIS DOCUMENT MAY BE REPRODUCED WITHOUT PRIOR AGREEMENT AND WRITTEN PERMISSION OF
FORD PERFORMANCE PARTS © Ford Motor Company 2020

- Position the wheel to align the valve stem with the machine arm, at the 6 o'clock position and mount the bottom bead of the tire.

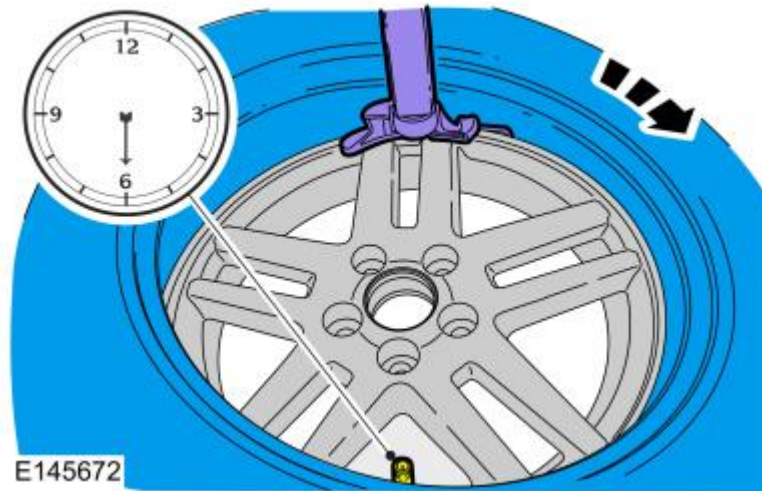

- Reposition the wheel to align the valve stem with the machine arm at the 6 o'clock position and mount the top bead of the tire.
- NOTE:** Use only the Digital Tire Pressure Gauge any time tire pressures are measured to be sure that accurate values are obtained.

Inflate the tire to the pressure specified on the VC label located on the driver door or door pillar.

NOTE: Proceed to the next step if the tire beads do not seat at the specified inflation pressure.

- ⚠ WARNING:** If there is a need to exceed the maximum pressure indicated on the sidewall of the tire in order to seat the beads, follow all steps listed below. Failure to follow these steps may result in serious personal injury.

NOTICE: The following steps should only be carried out if the tire beads cannot be seated by inflating the tire up to the maximum inflation pressure listed on the tire sidewall.

- Relubricate the tire bead and wheel bead seat area.
- Install a remote valve and pressure gauge.
- Wear eye and ear protection and stand at a minimum of 3.65 m (12 ft) away from the wheel and tire assembly.
- Inflate the tire using the remote valve and tire gauge until the beads have seated or until the pressure gauge is 138 kPa (20 psi) more than maximum inflation pressure on tire sidewall. If beads have not seated, deflate the tire and proceed to the next step.

Ford Factory Shop Manual purchase options www.motorcraftservice.com

NO PART OF THIS DOCUMENT MAY BE REPRODUCED WITHOUT PRIOR AGREEMENT AND WRITTEN PERMISSION OF
FORD PERFORMANCE PARTS © Ford Motor Company 2020

11. Place the wheel and tire assembly in an OSHA-approved tire safety cage.
12. Inflate the tire using the remote valve and pressure gauge until the beads have seated or until the pressure gauge is 276 kPa (40 psi) more than maximum inflation pressure on the tire sidewall. **Do not exceed 276 kPa (40 psi) above the maximum pressure on tire sidewall. Install a new tire if the beads do not seat at this pressure.**
13.  **WARNING:** When a wheel is installed, always remove any corrosion, dirt or foreign material present on the mounting surface of the wheel and the mounting surface of the wheel hub, brake drum or brake disc. Make sure that any fasteners that attach the rotor to the hub are secured so they do not interfere with the mounting surfaces of the wheel. Failure to follow these instructions when installing wheels may result in the wheel nuts loosening and the wheel coming off while the vehicle is in motion, which could result in loss of control, leading to serious injury or death to vehicle occupant(s).

NOTICE: Make sure to apply a thin coat of anti-seize lubrication only to the interface between the wheel pilot bore and the hub pilot. Do not allow the anti-seize to make contact with the wheel-to-brake disc/drum mounting surface, wheel studs, wheel nuts, brake pads or brake disc friction surfaces or damage to components may occur.

Clean the mounting surfaces. Apply anti-seize lubrication.

Material: Motorcraft® High Temperature Nickel Anti-Seize Lubricant / XL-2

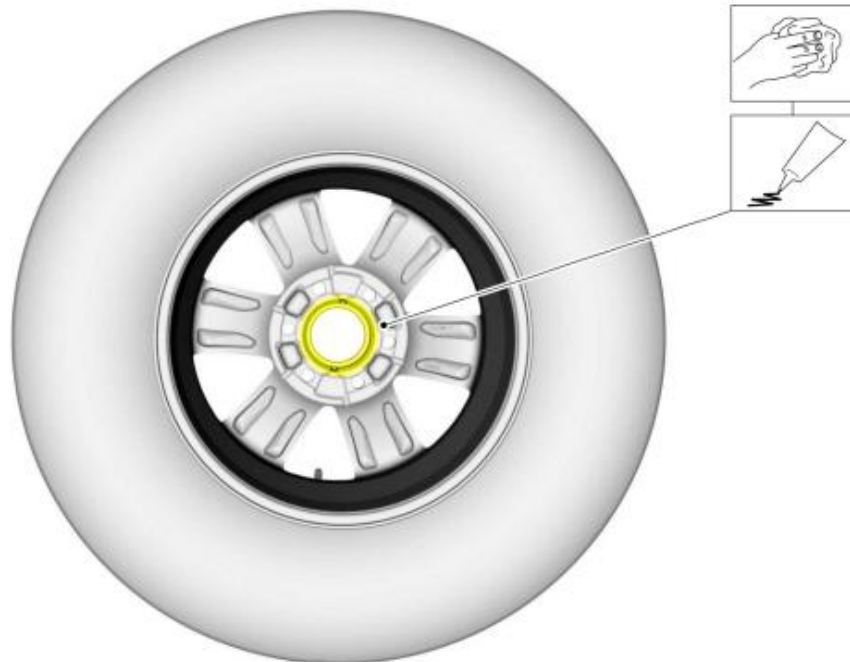

E190251

Ford Factory Shop Manual purchase options www.motorcraftservice.com



M-F150-W1,W2,W3,W4,W5
2025-26MY F-150 Super Crew XLT Black Pack & Black Pack Plus
Regional Package

NO PART OF THIS DOCUMENT MAY BE REPRODUCED WITHOUT PRIOR AGREEMENT AND WRITTEN PERMISSION OF
FORD PERFORMANCE PARTS © Ford Motor Company 2020

14. **NOTE:** *Only tighten the nuts finger tight at this stage.*

Install the wheel and tire and install the wheel nuts.



E250927

Ford Factory Shop Manual purchase options www.motorcraftservice.com

NO PART OF THIS DOCUMENT MAY BE REPRODUCED WITHOUT PRIOR AGREEMENT AND WRITTEN PERMISSION OF
FORD PERFORMANCE PARTS © Ford Motor Company 2020

15.  **WARNING: Retighten wheel nuts within 160 km (100 mi) after a wheel is reinstalled. Wheels can loosen after initial tightening. Failure to follow this instruction may result in serious injury to vehicle occupant(s).**

NOTICE: Failure to tighten the wheel nuts in a star/cross pattern can result in high brake disc runout, which accelerates the development of brake roughness, shudder and vibration.

NOTE: The wheel nut torque specification is for clean, dry wheel stud and wheel nut threads.

NOTE: Use metric hexagonal socket.

NOTE: Final tightening to be performed with vehicle resting on tires.

Tighten the wheel nuts.

Torque: 150 lb.ft (204 Nm)

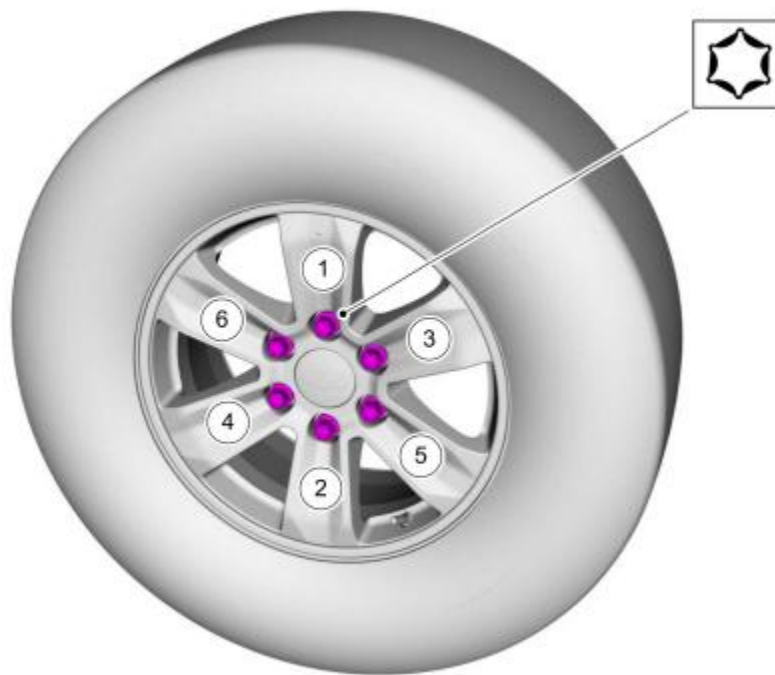

E190252

NO PART OF THIS DOCUMENT MAY BE REPRODUCED WITHOUT PRIOR AGREEMENT AND WRITTEN PERMISSION OF
FORD PERFORMANCE PARTS © Ford Motor Company 2020

16. **NOTE:** *If equipped.*

Install the center cap.

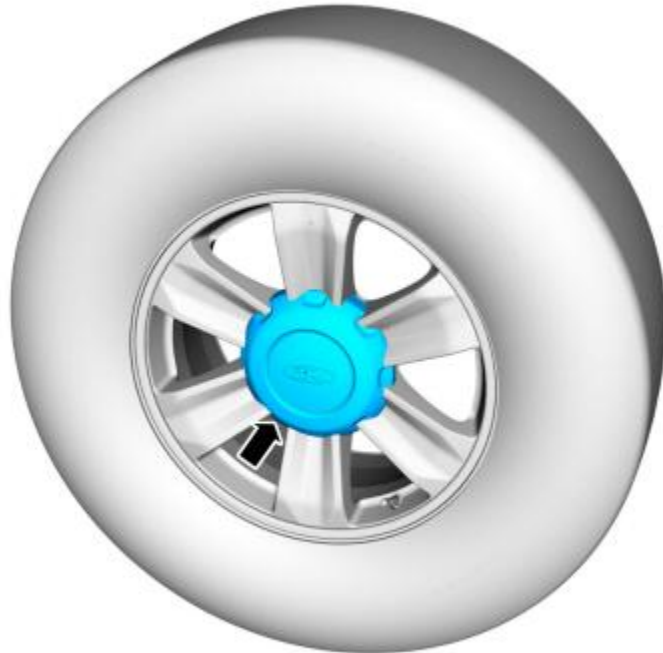

E190249

Check alignment, adjust as necessary.

Ford Factory Shop Manual purchase options www.motorcraftservice.com

NO PART OF THIS DOCUMENT MAY BE REPRODUCED WITHOUT PRIOR AGREEMENT AND WRITTEN PERMISSION OF
FORD PERFORMANCE PARTS © Ford Motor Company 2020

Tire Pressure Monitoring System (TPMS) Sensor Activation Special Tool(s) / General Equipment

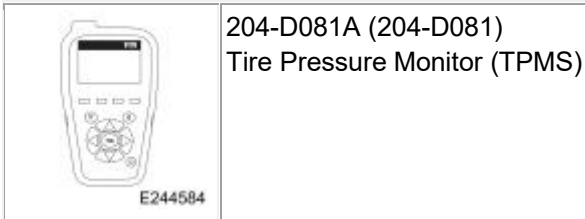

Activation

1. **NOTE:** *The tire pressure sensors will go into a sleep mode when the vehicle is stationary to conserve battery power. The sensors transmit information infrequently while in sleep mode. It is necessary to wake them up to transmit the latest tire pressure information.*

NOTE: *The tire pressure data in the BCM can be cleared when the module performs a reset. When this occurs, the air pressure DIDs are reset to the factory default of 1033 kPa (149.96 psi) and the cluster displays dashes. Drive your vehicle for at least 2 minutes over 32 km/h (20 mph) or until the tire pressures are displayed. Alternatively follow the procedure below:*

NOTE: *Position the vehicle 1m away from other vehicles to prevent interference from other vehicle tire pressure sensors. Turn the ignition switch to the ON position.*

2. Position the special tool against the LF tire sidewall at the tire valve stem.
Use Special Service Tool: 204-D081A (204-D081) Tire Pressure Monitor (TPMS).
3. **NOTE:** *The special service tool should provide feedback in the form of a beep for each successful response from a tire pressure sensor. This feedback confirms that the tire sensor has responded, but does not confirm that the vehicle receiver module has heard the response.*

NOTE: *If the receiver module has not heard the sensor response, move the vehicle to rotate the wheels at least one-fourth of a turn and attempt to activate the sensor again. If the sensor is still not heard, attempt to activate again with the vehicle doors open.*

Press the test button on the special tool to activate the sensor.

Use Special Service Tool: 204-D081A (204-D081) Tire Pressure Monitor (TPMS).

4. Repeat Steps 2 and 3 for the remaining tires. The normal sequence is LF (as above) followed by RF, RR and LR.
5. **NOTE:** *The TPMS sensor cannot be installed without disassembly of the wheel and tire.*

If a tire pressure sensor does not respond to the service tool when positioned against the tire sidewall at the valve stem, repeat the test with the tool antenna lightly resting on the valve cap. If after 3 attempts, one or more sensors does not respond or has a low battery, diagnose the TPMS and replace as necessary.

Refer to: Tire Pressure Monitoring System (TPMS) (204-04B Tire Pressure Monitoring System (TPMS), Diagnosis and Testing).

NO PART OF THIS DOCUMENT MAY BE REPRODUCED WITHOUT PRIOR AGREEMENT AND WRITTEN PERMISSION OF
FORD PERFORMANCE PARTS © Ford Motor Company 2020

Tire Pressure Monitoring System (TPMS) Sensor Location Calibration Special Tool(s) / General Equipment

	204-D081A (204-D081) Tire Pressure Monitor (TPMS)
Ford Diagnostic Equipment	

Programming

NOTE: The TPMS can be placed into learn mode using a diagnostic scan tool or manually where a diagnostic scan tool is not available.

NOTE: The horn sounds once and the TPMS indicator will flash if the training mode has been entered successfully. If equipped, the message center displays TRAIN LF TIRE.

1. **NOTE: Enter Training Mode With IDS Scan Tool**

1. Select Chassis.
2. Select TPMS .
3. Select Training Mode.
Use the General Equipment: Ford Diagnostic Equipment

2. **NOTE: Enter Training Mode With FDRS Scan Tool**

1. Select Toolbox.
2. Select BCM .
3. Select BCM — TPMS Initialization.
Use the General Equipment: Ford Diagnostic Equipment

Programming

NOTE: Enter Training Mode Without Scan Tool

1. **NOTE:** The horn sounds once and the TPMS indicator flashes if the training mode has been entered successfully. If equipped, the message center displays TRAIN LF TIRE.

With the ignition off , press and release the brake pedal.

2. Using the start/stop switch, position the ignition from OFF to RUN 3 times, ending in the RUN position.
3. Press and release the brake pedal.
4. Position the ignition to OFF position.

Ford Factory Shop Manual purchase options www.motorcraftservice.com



NO PART OF THIS DOCUMENT MAY BE REPRODUCED WITHOUT PRIOR AGREEMENT AND WRITTEN PERMISSION OF
FORD PERFORMANCE PARTS © Ford Motor Company 2020

- Using the start/stop switch, position the ignition from OFF to RUN 3 times, ending in the RUN position.

Programming

NOTE: *TPMS Sensor Training Procedure*

- NOTE:** *It may take up to 6 seconds to activate a tire pressure sensor. During this time, the special tool must remain in place at the valve stem.*

Within 2 minutes of the horn sounding, place the special tool on the LF tire sidewall at the valve stem. Press and release the test button on the special tool. The horn briefly sounds to indicate that the tire pressure sensor has been recognized by the BCM .

Use Special Service Tool: 204-D081A (204-D081) Tire Pressure Monitor (TPMS).

- Within 2 minutes of the horn sounding, place the special tool on the RF tire sidewall at the valve stem and press and release the test button to train the RF tire pressure sensor.

Use Special Service Tool: 204-D081A (204-D081) Tire Pressure Monitor (TPMS).

- Repeat Step 1 for the RR within 2 minutes of the horn sounding, place the special tool on the RR tire sidewall at the valve stem and press and release the test button to train the RR tire pressure sensor. For LR tires within 2 minutes of the horn sounding, place the special tool on the LR tire sidewall at the valve stem and press and release the test button to train the LR tire pressure sensor. The procedure is completed after the last tire has been trained. When the training procedure is completed, the message center (if equipped) will display TIRE TRAINING COMPLETE. For vehicles not equipped with a message center, successful completion of the training procedure is verified by positioning the ignition to OFF without the horn sounding. If the horn sounds twice when the ignition is positioned to OFF, the training procedure was not successful.
- Using the scan tool, locate the updated TPMS sensor identifiers trained to the BCM and document them on the applicable warranty claim.
Use Special Service Tool: 204-D081A (204-D081) Tire Pressure Monitor (TPMS).
- NOTE:** *This step is required to clear DTC B1182:55, cause the BCM to exit the manufacturing mode and to make sure there are no other concerns with a newly programmed BCM .*

If the sensors are being trained due to the installation of a new BCM , clear any DTC s and carry out the BCM On-Demand Self Test.

IMPORTANT: After completing the procedure, clear any DTCs.

IMPORTANT: Verify there are no IPC warnings or recurring DTCs.

NO PART OF THIS DOCUMENT MAY BE REPRODUCED WITHOUT PRIOR AGREEMENT AND WRITTEN PERMISSION OF
FORD PERFORMANCE PARTS © Ford Motor Company 2020

Cruise Control Radar Alignment (if equipped)

Adjustment

Vertical Alignment

NOTE: In order to align the CCM, the front bumper trim panel must be removed to access the sensor and the vehicle must be in a wheel alignment bay station so that the vehicle is level.

NOTE: Damage to the CCM bracket may affect correct alignment. When aligning the CCM, inspect the CCM bracket for damage and repair as necessary before carrying out the alignment procedure.

Remove the front bumper trim panel.



E263322

NO PART OF THIS DOCUMENT MAY BE REPRODUCED WITHOUT PRIOR AGREEMENT AND WRITTEN PERMISSION OF FORD PERFORMANCE PARTS © Ford Motor Company 2020

Place the vehicle on a wheel alignment bay station.

Locate the CCM alignment screws.

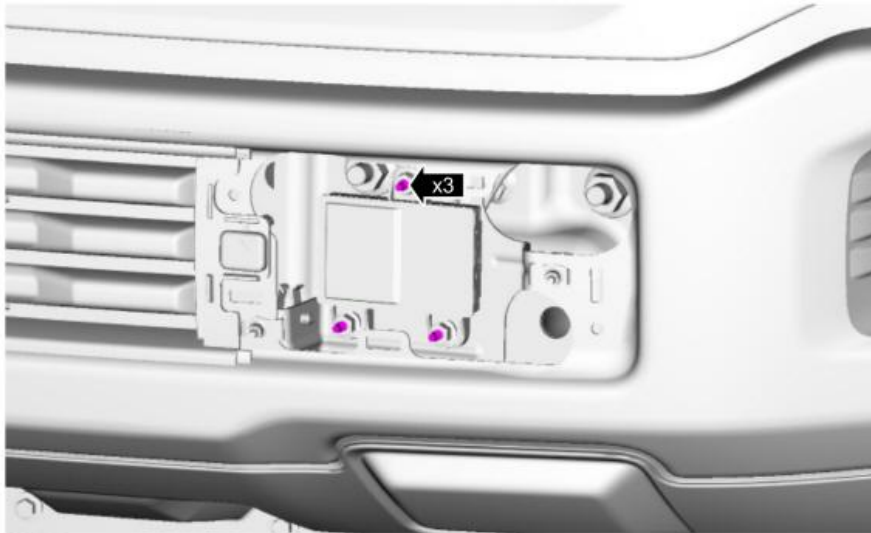

E263323

NOTE: *Typical application shown.*

Place a combination square level on the face of the CCM and check the alignment.



E192283

Ford Factory Shop Manual purchase options www.motorcraftservice.com

NO PART OF THIS DOCUMENT MAY BE REPRODUCED WITHOUT PRIOR AGREEMENT AND WRITTEN PERMISSION OF
FORD PERFORMANCE PARTS © Ford Motor Company 2020

Keeping the combination square level on the face of the CCM, adjust the pitch by using an E6 Torx® socket to adjust the screws until the CCM is vertical and level.



E263324

Install the front bumper trim panel.

Horizontal Alignment

NOTE: The horizontal alignment for the CCM is a software calibration that checks that the radar is pointed straight. No manual adjustment is needed for this procedure. The scan tool calibrates the CCM through the CCM procedure in programmable parameters.

NOTICE: The vehicle's engine must be running during the horizontal alignment procedure. Failure to leave the engine running throughout the entire procedure results in the cancellation of the alignment procedure and the system remains non-functional.

Start the engine.

NOTE: DTCs in the ABS and PCM modules can prevent the calibration from completing.

Follow the diagnostic scan tool on-screen instructions to carry-out the CCM calibration procedure

IMPORTANT: After completing the procedure, clear any DTCs.

IMPORTANT: Verify there are no IPC warnings or recurring DTCs.

Ford Factory Shop Manual purchase options www.motorcraftservice.com

NO PART OF THIS DOCUMENT MAY BE REPRODUCED WITHOUT PRIOR AGREEMENT AND WRITTEN PERMISSION OF
FORD PERFORMANCE PARTS © Ford Motor Company 2020

Aim headlights

ADJUSTING THE HEADLAMPS

Vertical Aim Adjustment

The headlamps on your vehicle are properly aimed at the assembly plant. If your vehicle has been in an accident, contact an authorized dealer to check and realign your headlamps.

Headlamp Aiming Target

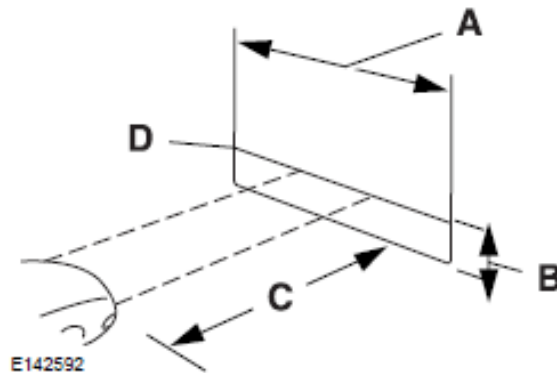

- A 8 feet (2.4 meters).
- B Center height of lamp to ground.
- C 25 feet (7.6 meters).
- D Horizontal reference line.

Vertical Aim Adjustment

1. Park your vehicle directly in front of a wall or screen on a level surface, approximately 25 ft (7.6 m) away.



FORD PERFORMANCE

M-F150-W1,W2,W3,W4,W5

2025-26MY F-150 Super Crew XLT Black Pack & Black Pack Plus
Regional Package

NO PART OF THIS DOCUMENT MAY BE REPRODUCED WITHOUT PRIOR AGREEMENT AND WRITTEN PERMISSION OF
FORD PERFORMANCE PARTS © Ford Motor Company 2020

2. Measure the height from the center of your headlamp (indicated by a 3.0 millimeter circle on the lens) to the ground and mark an 8 ft (2.4 m) horizontal reference line on the vertical wall or screen at this height (a piece of masking tape works well).

Note: *To see a clearer light pattern for adjusting, you may want to block the light from one headlamp while adjusting the other.*

3. Switch on the low beam headlamps to illuminate the wall or screen and open the hood. Cover one of the headlamps so no light hits the wall.



E167358

4. **For halogen or LED headlamps:** On the wall or screen you will observe a light pattern with a distinct horizontal edge toward the right. If this edge is not at the horizontal reference line, you will need to adjust the beam so the edge is at the same height as the horizontal reference line.

Ford Factory Shop Manual purchase options www.motorcraftservice.com

NO PART OF THIS DOCUMENT MAY BE REPRODUCED WITHOUT PRIOR AGREEMENT AND WRITTEN PERMISSION OF
FORD PERFORMANCE PARTS © Ford Motor Company 2020



E163806

5. Locate the vertical adjuster on each headlamp. Use a #2 Phillips screwdriver to turn the adjuster either counterclockwise or clockwise in order to adjust the vertical aim of the headlamp.
6. Repeat Steps 3 through 7 to adjust the other headlamp.
7. Close the hood and turn off the lamps.

Horizontal Aim Adjustment

Horizontal aim is not required for this vehicle and is not adjustable.

IMPORTANT: After completing the procedure, clear any DTCs.

IMPORTANT: Verify there are no IPC warnings or recurring DTCs.